



# Dual, 10-Bit, 40MHz, Current/Voltage Simultaneous-Output DACs

## General Description

The MAX5180 contains two 10-bit, simultaneous-update, current output digital-to-analog converters (DACs) designed for superior performance in communications systems requiring analog signal reconstruction with low distortion and low-power operation. The MAX5183 provides equal specifications, with on-chip precision resistors for voltage output operation. Both devices are designed for 10pVs glitch operation to minimize unwanted spurious signal components at the output. An on-board +1.2V bandgap circuit provides a well-regulated, low-noise reference that can be disabled for external reference operation.

The MAX5180/MAX5183 are designed to provide a high level of signal integrity for the least amount of power dissipation. Both DACs operate from a single supply of +2.7V to +3.3V. Additionally, these DACs have three modes of operation: normal, low-power standby, and complete shutdown, which provides the lowest possible power dissipation with 1µA (max) shutdown current. A fast wake-up time (0.5µs) from standby mode to full DAC operation conserves power by activating the DACs only when required.

The MAX5180/MAX5183 are packaged in a 28-pin QSOP and are specified for the extended (-40°C to +85°C) temperature range. For lower-resolution, dual 8-bit versions, refer to the MAX5186/MAX5189 data sheet.

## Applications

- Signal Reconstruction of I and Q Transmit Signals
- Digital Signal Processing
- Arbitrary Waveform Generation (AWG)
- Imaging

## Features

- ◆ +2.7V to +3.3V Single-Supply Operation
- ◆ Wide Spurious-Free Dynamic Range: 70dB at  $f_{OUT} = 2.2\text{MHz}$
- ◆ Fully Differential Outputs for Each DAC
- ◆  $\pm 0.5\%$  FSR Gain Mismatch
- ◆  $\pm 0.2^\circ$  Phase Mismatch
- ◆ Low-Current Standby or Full Shutdown Modes
- ◆ Internal +1.2V Low-Noise Bandgap Reference
- ◆ Small 28-Pin QSOP Package

## Ordering Information

PART	TEMP. RANGE	PIN-PACKAGE
MAX5180BEEI	-40°C to +85°C	28 QSOP
MAX5183BEEI	-40°C to +85°C	28 QSOP

## Pin Configuration

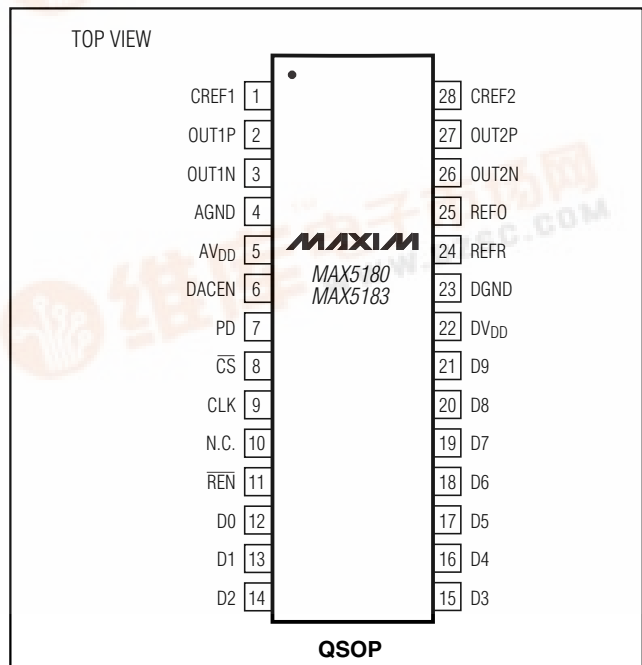

MAX5180/MAX5183



# Dual, 10-Bit, 40MHz, Current/Voltage Simultaneous-Output DACs

## ABSOLUTE MAXIMUM RATINGS

AV <sub>DD</sub> , DV <sub>DD</sub> to AGND, DGND .....	-0.3V to +6V	Maximum Current into Any Pin.....	50mA
Digital Inputs to DGND .....	-0.3V to +6V	Continuous Power Dissipation (T <sub>A</sub> = +70°C)	
OUT1P, OUT1N, OUT2P, OUT2N, CREF1, CREF2 to AGND .....	-0.3V to +6V	28-Pin QSOP (derate 9.00mW/°C above +70°C).....	725mW
V <sub>REF</sub> to AGND .....	-0.3V to +6V	Operating Temperature Range	
AGND to DGND.....	-0.3V to +0.3V	MAX518_BEEI.....	-40°C to +85°C
AV <sub>DD</sub> to DV <sub>DD</sub> .....	±3.3V	Storage Temperature Range .....	-65°C to +150°C
		Lead Temperature (soldering, 10sec).....	+300°C

Stresses beyond those listed under "Absolute Maximum Ratings" may cause permanent damage to the device. These are stress ratings only, and functional operation of the device at these or any other conditions beyond those indicated in the operational sections of the specifications is not implied. Exposure to absolute maximum rating conditions for extended periods may affect device reliability.

## ELECTRICAL CHARACTERISTICS

(AV<sub>DD</sub> = DV<sub>DD</sub> = +3V ±10%, AGND = DGND = 0, f<sub>CLK</sub> = 40MHz, I<sub>FS</sub> = 1mA, 400Ω differential output, C<sub>L</sub> = 5pF, T<sub>A</sub> = T<sub>MIN</sub> to T<sub>MAX</sub>, unless otherwise noted. Typical values are at T<sub>A</sub> = +25°C.)

PARAMETER	SYMBOL	CONDITIONS	MIN	TYP	MAX	UNITS
<b>STATIC PERFORMANCE</b>						
Resolution	N		10			Bits
Integral Nonlinearity	INL		-2	±0.5	+2	LSB
Differential Nonlinearity	DNL	Guaranteed monotonic	-1	±0.5	+1	LSB
Zero-Scale Error		MAX5180	-2		+2	LSB
		MAX5183	-8		+8	
Full-Scale Error		(Note 1)	-40	±15	+40	LSB
<b>DYNAMIC PERFORMANCE</b>						
Output Settling Time		To ±0.5LSB error band		25		ns
Glitch Impulse				10		pVs
Spurious-Free Dynamic Range to Nyquist	SFDR	f <sub>CLK</sub> = 40MHz	f <sub>OUT</sub> = 550kHz		72	dBc
			f <sub>OUT</sub> = 2.2MHz	57	70	
Total Harmonic Distortion to Nyquist	THD	f <sub>CLK</sub> = 40MHz	f <sub>OUT</sub> = 550kHz		-70	dB
			f <sub>OUT</sub> = 2.2MHz		-68	
Signal-to-Noise Ratio to Nyquist	SNR	f <sub>CLK</sub> = 40MHz	f <sub>OUT</sub> = 550kHz		61	dB
			f <sub>OUT</sub> = 2.2MHz		59	
DAC-to-DAC Output Isolation		f <sub>OUT</sub> = 2.2MHz	56	-60		dB
Clock and Data Feedthrough		All 0s to all 1s		50		nVs
Output Noise				10		pA/√Hz
Gain Mismatch Between DAC Outputs		f <sub>OUT</sub> = 2.2MHz		±0.5	±1	%FSR
Phase Mismatch Between DAC Outputs		f <sub>OUT</sub> = 2.2MHz		±0.15		degrees
<b>ANALOG OUTPUT</b>						
Full-Scale Output Voltage	V <sub>FS</sub>			400		mV
Voltage Compliance of Output			-0.3		0.8	V
Output Leakage Current		DACEN = 0, MAX5180 only	-1		1	μA
Full-Scale Output Current	I <sub>FS</sub>	MAX5180 only	0.5	1	1.5	mA
DAC External Output Resistor Load	R <sub>L</sub>	MAX5180 only		400		Ω

# Dual, 10-Bit, 40MHz, Current/Voltage Simultaneous-Output DACs

MAX5180/MAX5183

## ELECTRICAL CHARACTERISTICS (continued)

( $V_{DD} = DV_{DD} = +3V \pm 10\%$ ,  $AGND = DGND = 0$ ,  $f_{CLK} = 40MHz$ ,  $I_{FS} = 1mA$ ,  $400\Omega$  differential output,  $C_L = 5pF$ ,  $T_A = T_{MIN}$  to  $T_{MAX}$ , unless otherwise noted. Typical values are at  $T_A = +25^\circ C$ .)

PARAMETER	SYMBOL	CONDITIONS	MIN	TYP	MAX	UNITS
<b>REFERENCE</b>						
Output Voltage Range	$V_{REF}$		1.12	1.2	1.28	V
Output Voltage Temperature Drift	$TCV_{REF}$			50		ppm/ $^\circ C$
Reference Output Drive Capability	$I_{REFOUT}$			10		$\mu A$
Reference Supply Rejection				0.5		mV/V
Current Gain ( $I_{FS} / I_{REF}$ )				8		mA/mA
<b>POWER REQUIREMENTS</b>						
Analog Power-Supply Voltage	$AV_{DD}$		2.7		3.3	V
Analog Supply Current	$I_{AVDD}$	PD = 0, DACEN = 1, digital inputs at 0 or $DV_{DD}$		2.7	5.0	mA
Digital Power-Supply Voltage	$DV_{DD}$		2.7		3.3	V
Digital Supply Current	$I_{DVDD}$	PD = 0, DACEN = 1, digital inputs at 0 or $DV_{DD}$		4.2	5.0	mA
Standby Current	$I_{STANDBY}$	PD = 0, DACEN = 0, digital inputs at 0 or $DV_{DD}$		1.0	1.5	mA
Shutdown Current	$I_{SHDN}$	PD = 1, DACEN = X, digital inputs at 0 or $DV_{DD}$ (X = don't care)		0.5	1.0	$\mu A$
<b>LOGIC INPUTS AND OUTPUTS</b>						
Digital Input Voltage High	$V_{IH}$		2			V
Digital Input Voltage Low	$V_{IL}$				0.8	V
Digital Input Current	$I_{IN}$	$V_{IN} = 0$ or $DV_{DD}$			$\pm 1$	$\mu A$
Digital Input Capacitance	$C_{IN}$			10		pF
<b>TIMING CHARACTERISTICS</b>						
DAC1 DATA to CLK Rise Setup Time	$t_{DS1}$		10			ns
DAC2 DATA to CLK Fall Setup Time	$t_{DS2}$		10			ns
DAC1 CLK Rise to DATA Hold Time	$t_{DH1}$		0			ns
DAC2 CLK Fall to DATA Hold Time	$t_{DH2}$		0			ns
$\overline{CS}$ Fall to CLK Rise Time				5		ns
$\overline{CS}$ Fall to CLK Fall Time				5		ns
DACEN Rise Time to $V_{OUT\_}$				0.5		$\mu s$
PD Fall Time to $V_{OUT\_}$				50		$\mu s$
Clock Period	$t_{CP}$		25			ns
Clock High Time	$t_{CH}$		10			ns
Clock Low Time	$t_{CL}$		10			ns

# Dual, 10-Bit, 40MHz, Current/Voltage Simultaneous-Output DACs

## Typical Operating Characteristics

( $V_{DD} = DV_{DD} = +3V$ ,  $AGND = DGND = 0$ ,  $400\Omega$  differential output,  $I_{FS} = 1mA$ ,  $C_L = 5pF$ ,  $T_A = +25^\circ C$ , unless otherwise noted.)

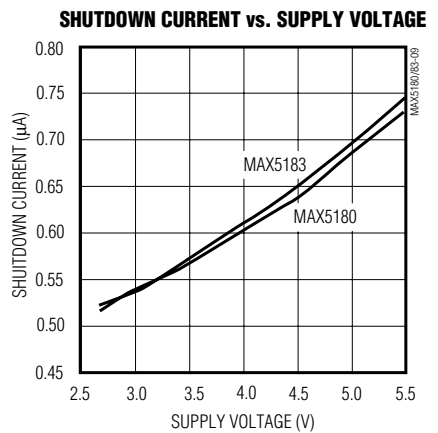
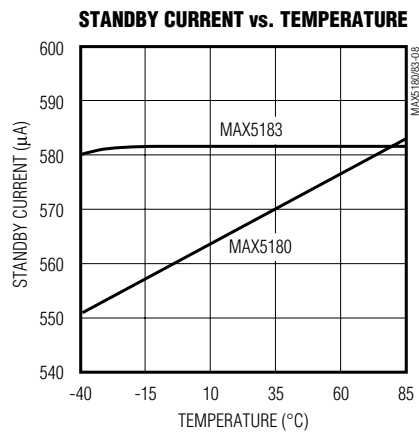
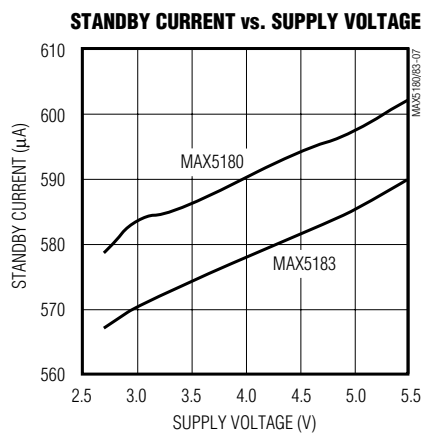
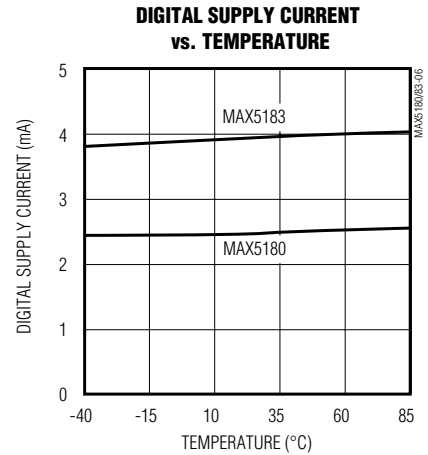
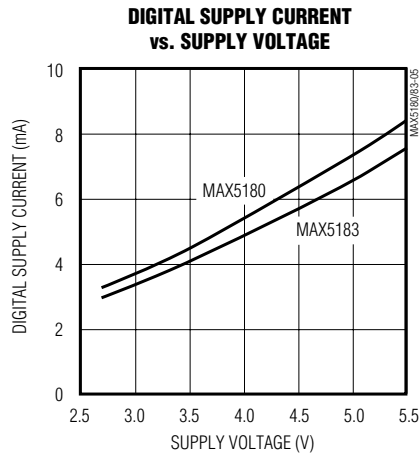
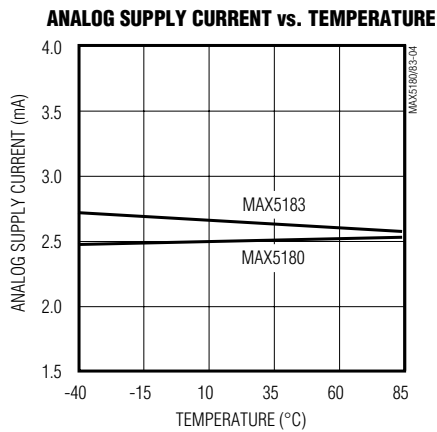
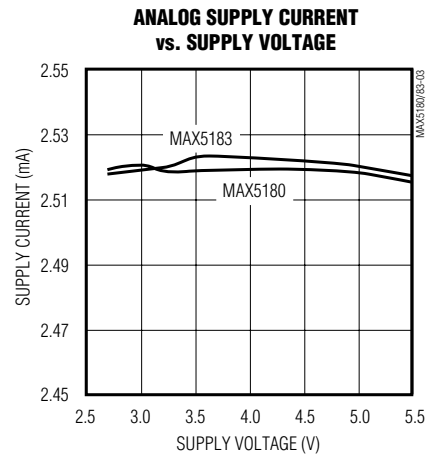
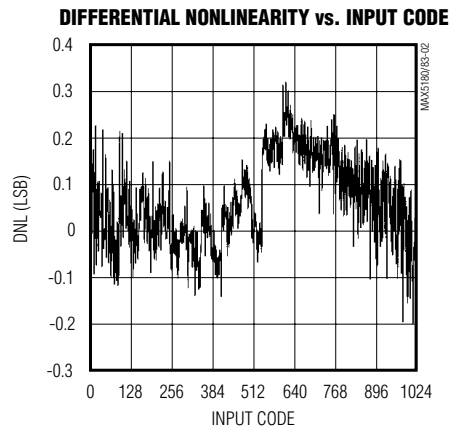
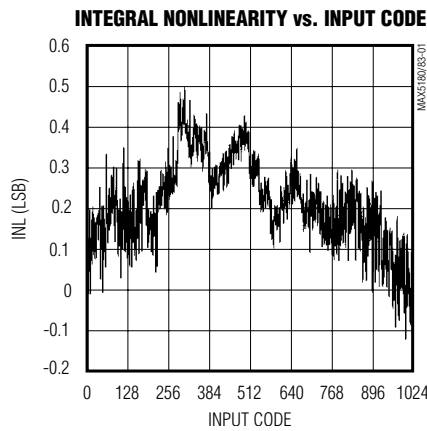

# Dual, 10-Bit, 40MHz, Current/Voltage Simultaneous-Output DACs

## Typical Operating Characteristics (continued)

( $V_{DD} = DV_{DD} = +3V$ ,  $AGND = DGND = 0$ ,  $400\Omega$  differential output,  $I_{FS} = 1mA$ ,  $C_L = 5pF$ ,  $T_A = +25^\circ C$ , unless otherwise noted.)

**MAX5180/MAX5183**

**INTERNAL REFERENCE VOLTAGE vs. SUPPLY VOLTAGE**

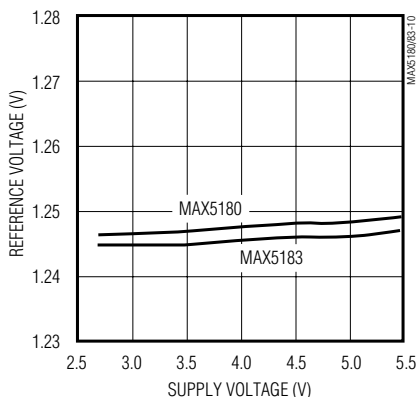

**INTERNAL REFERENCE VOLTAGE vs. TEMPERATURE**

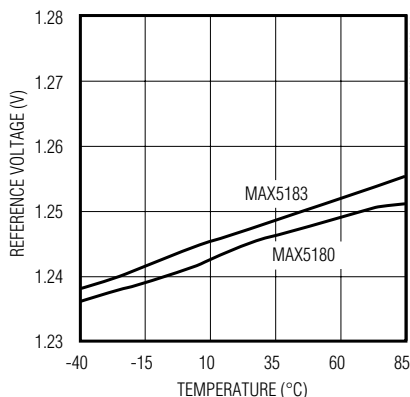

**OUTPUT CURRENT vs. REFERENCE CURRENT**

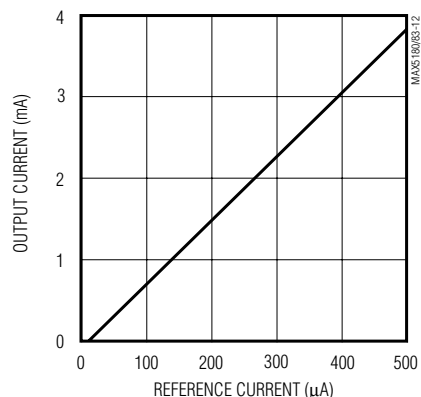

**DYNAMIC RESPONSE RISE TIME**

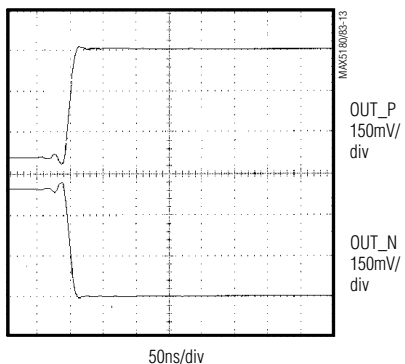

**DYNAMIC RESPONSE FALL TIME**

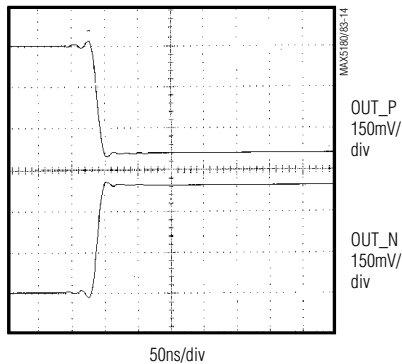

**SETTLING TIME**

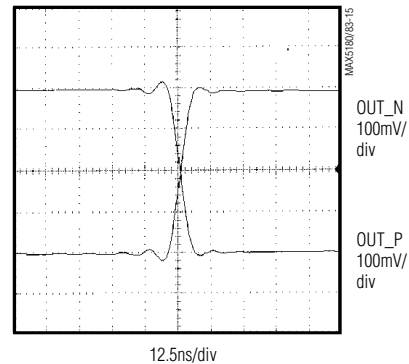

**FFT PLOT, DAC1**

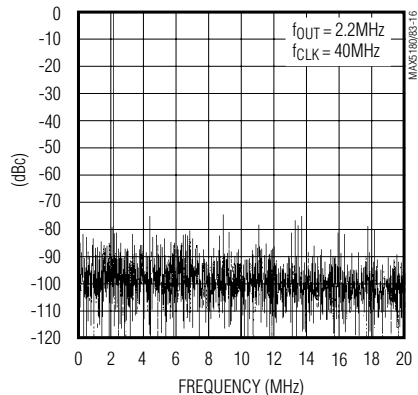

**FFT PLOT, DAC2**

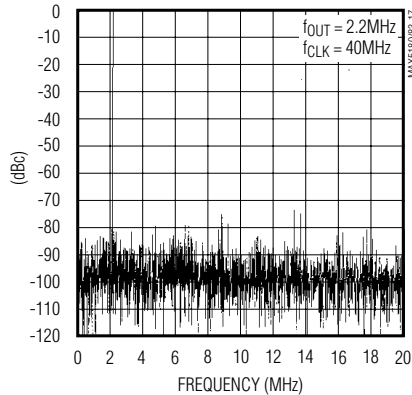

**SPURIOUS-FREE DYNAMIC RANGE vs. CLOCK FREQUENCY**

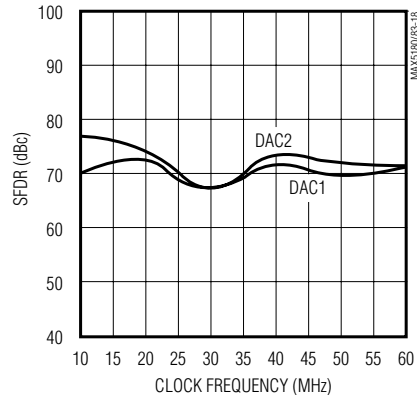

# Dual, 10-Bit, 40MHz, Current/Voltage Simultaneous-Output DACs

## Typical Operating Characteristics (continued)

( $V_{DD} = DV_{DD} = +3V$ ,  $AGND = DGND = 0$ ,  $400\Omega$  differential output,  $I_{FS} = 1mA$ ,  $C_L = 5pF$ ,  $T_A = +25^\circ C$ , unless otherwise noted.)

**SPURIOUS-FREE DYNAMIC RANGE vs. OUTPUT FREQUENCY AND CLOCK FREQUENCY, DAC1**

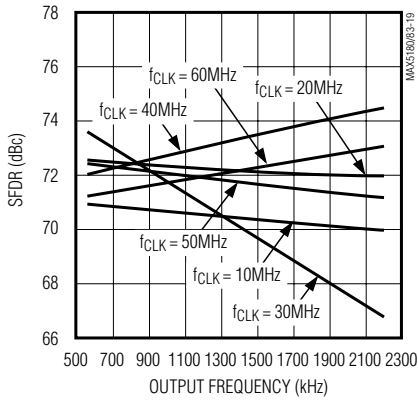

**SPURIOUS-FREE DYNAMIC RANGE vs. OUTPUT FREQUENCY AND CLOCK FREQUENCY, DAC2**

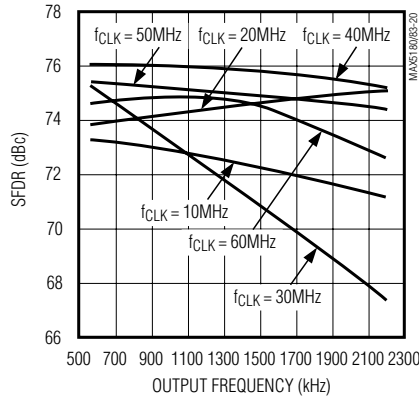

**SIGNAL-TO-NOISE PLUS DISTORTION vs. OUTPUT FREQUENCY**

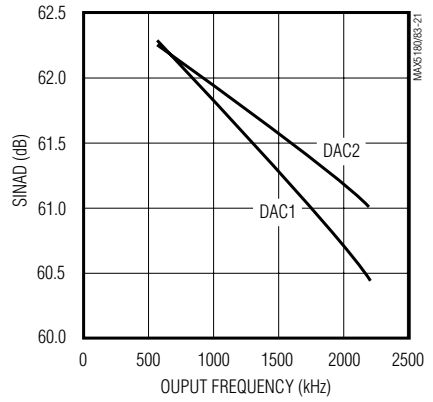

**SPURIOUS-FREE DYNAMIC RANGE vs. OUTPUT FREQUENCY**

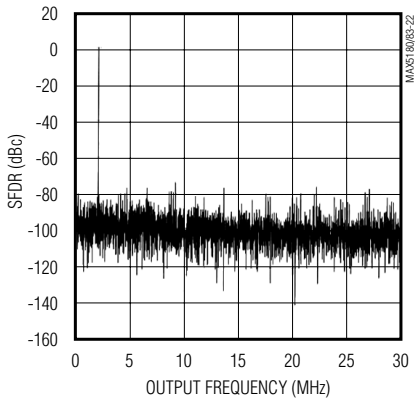

**MULTITONE SPURIOUS-FREE DYNAMIC RANGE vs. OUTPUT FREQUENCY**

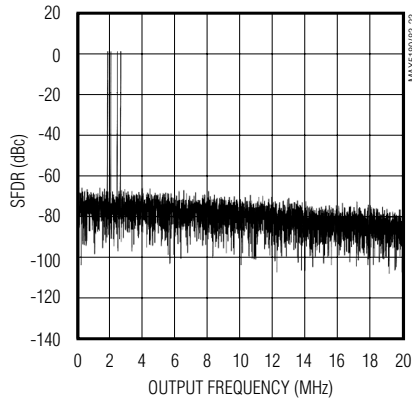

**SPURIOUS-FREE DYNAMIC RANGE vs. FULL-SCALE OUTPUT CURRENT**

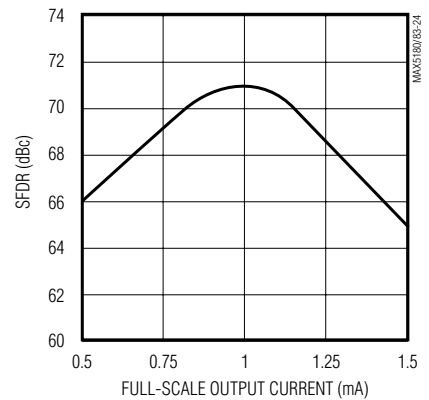

# Dual, 10-Bit, 40MHz, Current/Voltage Simultaneous-Output DACs

## Pin Description

MAX5180/MAX5183

PIN	NAME	FUNCTION
1	CREF1	Reference Bias Bypass, DAC1
2	OUT1P	Positive Analog Output, DAC1. Current output for MAX5180; voltage output for MAX5183.
3	OUT1N	Negative Analog Output, DAC1. Current output for MAX5180; voltage output for MAX5183.
4	AGND	Analog Ground
5	AV <sub>DD</sub>	Analog Positive Supply, +2.7V to +3.3V
6	DACEN	DAC Enable, Digital Input 0: Enter DAC standby mode with PD = DGND 1: Power-up DAC with PD = DGND X: Enter shutdown mode with PD = DV <sub>DD</sub> (X = don't care)
7	PD	Power-Down Select 0: Enter DAC standby mode (DACEN = DGND) or power-up DAC (DACEN = DV <sub>DD</sub> ) 1: Enter shutdown mode.
8	$\overline{\text{CS}}$	Active-Low Chip Select
9	CLK	Clock Input
10	N.C.	No Connect. Do not connect to this pin.
11	$\overline{\text{REN}}$	Active-Low Reference Enable. Connect to DGND to activate on-chip +1.2V reference.
12	D0	Data Bit D0 (LSB)
13–20	D1–D8	Data Bits D1–D8
21	D9	Data Bit D9 (MSB)
22	DV <sub>DD</sub>	Digital Supply, +2.7V to +3.3V
23	DGND	Digital Ground
24	REFR	Reference Input
25	REFO	Reference Output
26	OUT2N	Negative Analog Output, DAC2. Current output for MAX5180; voltage output for MAX5183.
27	OUT2P	Positive Analog Output, DAC2. Current output for MAX5180; voltage output for MAX5183.
28	CREF2	Reference Bias Bypass, DAC2

# Dual, 10-Bit, 40MHz, Current/Voltage Simultaneous-Output DACs

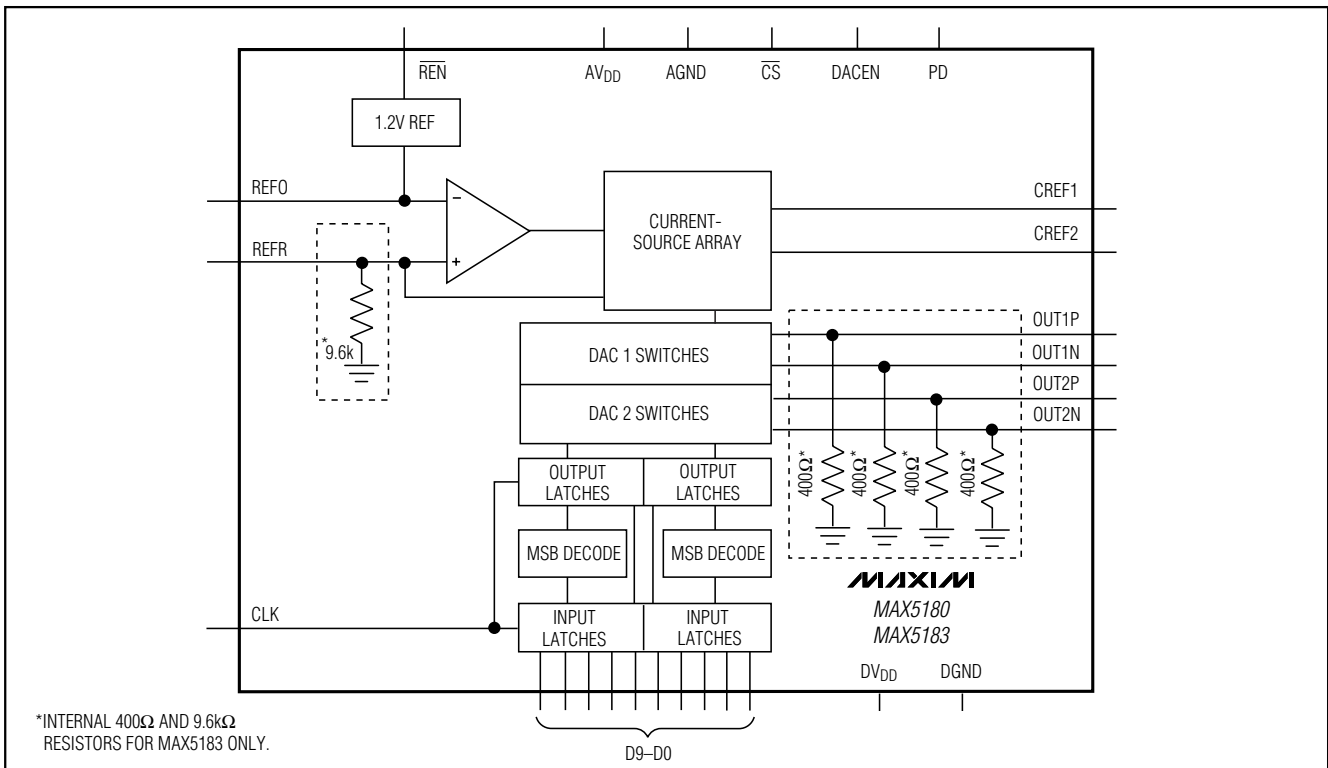

Figure 1. Functional Diagram

## Detailed Description

The MAX5180/MAX5183 are dual 10-bit digital-to-analog converters (DACs) capable of operating with clock speeds up to 40MHz. Each of these dual converters consists of separate input and DAC registers, followed by a current source array capable of generating up to 1.5mA full-scale output current (Figure 1). An integrated +1.2V voltage reference and control amplifier determine the data converters' full-scale output currents/voltages. Careful reference design ensures close gain matching and excellent drift characteristics. The MAX5183's voltage output operation features matched 400Ω on-chip resistors that convert the current array current into a voltage.

### Internal Reference and Control Amplifier

The MAX5180/MAX5183 provide an integrated 50ppm/°C, +1.2V, low-noise bandgap reference that can be disabled and overridden by an external reference voltage. REFO serves either as an external reference input or an integrated reference output. If REN is connected to AGND, the internal reference is selected and REFO provides a +1.2V output. Due to its limited

10μA output drive capability, REFO must be buffered with an external amplifier if heavier loading is required.

The MAX5180/MAX5183 also employ a control amplifier designed to simultaneously regulate the full-scale output current (I<sub>FS</sub>) for both outputs of the devices. The output current is calculated as follows:

$$I_{FS} = 8 \cdot I_{REF}$$

where I<sub>REF</sub> is the reference output current (I<sub>REF</sub> = V<sub>REF0</sub>/R<sub>SET</sub>) and I<sub>FS</sub> is the full-scale output current. R<sub>SET</sub> is the reference resistor that determines the amplifier's output current on the MAX5180 (Figure 2). This current is mirrored into the current-source array where it is equally distributed between matched current segments and summed to valid output current readings for the DACs.

The MAX5183 converts each output current (DAC1 and DAC2) into an output voltage (V<sub>OUT1</sub>, V<sub>OUT2</sub>) with two internal, ground-referenced 400Ω load resistors. Using the internal +1.2V reference voltage, the MAX5183's integrated reference output current resistor (R<sub>SET</sub> = 9.6kΩ) sets I<sub>REF</sub> to 125μA and I<sub>FS</sub> to 1mA.



# Dual, 10-Bit, 40MHz, Current/Voltage Simultaneous-Output DACs

MAX5180/MAX5183

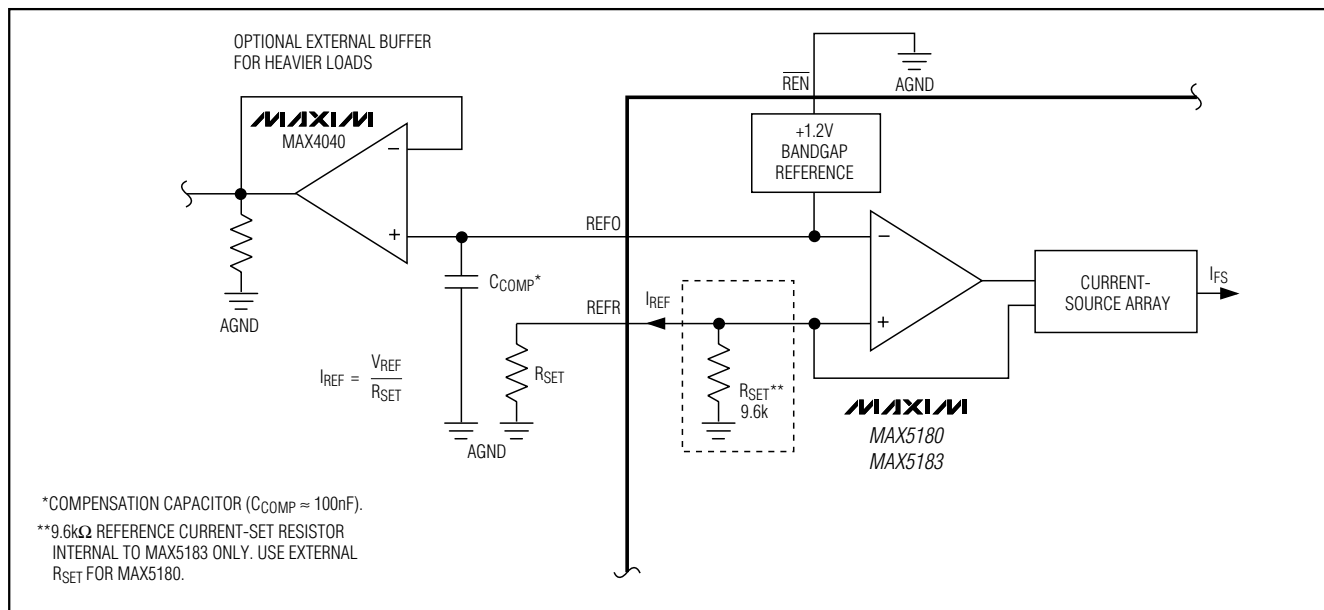

Figure 2. Setting I<sub>FS</sub> with the Internal +1.2V Reference and the Control Amplifier

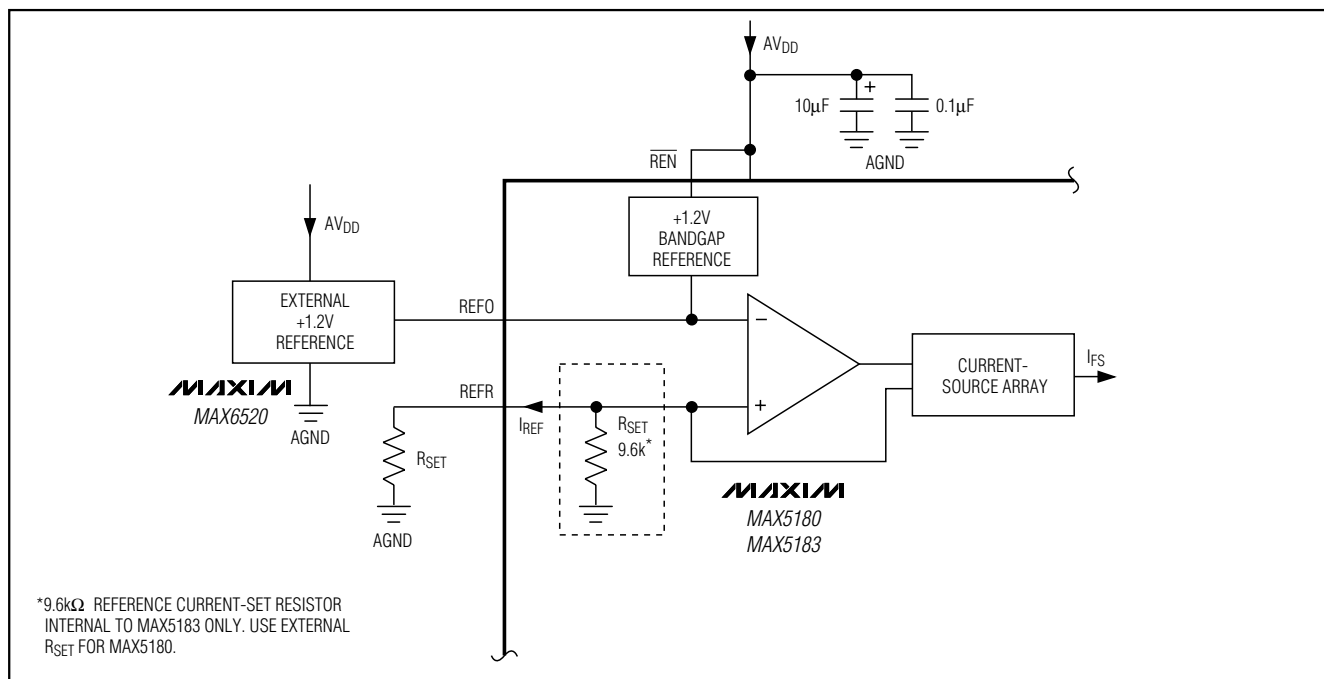

Figure 3. MAX5180/MAX5183 with External Reference

# Dual, 10-Bit, 40MHz, Current/Voltage Simultaneous-Output DACs

## External Reference

To disable the MAX5180/MAX5183's internal reference, connect  $\overline{\text{REN}}$  to  $\text{AV}_{\text{DD}}$ . A temperature-stable, external reference may now be applied to drive the REFO pin to set the full-scale output (Figure 3). Choose a reference capable of supplying at least  $150\mu\text{A}$  to drive the bias circuit that generates the cascode current for the current array. For improved accuracy and drift performance, choose a fixed output voltage reference such as the  $+1.2\text{V}$ ,  $25\text{ppm}/^\circ\text{C}$  MAX6520 bandgap reference.

## Standby Mode

To enter the lower power standby mode, connect digital inputs PD and DACEN to DGND. In standby, both the reference and the control amplifier are active with the current array inactive. To exit this condition, DACEN must be pulled high with PD held at DGND. Both the MAX5180 and MAX5183 typically require  $50\mu\text{s}$  to wake up and allow both the outputs and the reference to settle.

## Shutdown Mode

For lowest power consumption, the MAX5180/MAX5183 provide a power-down mode in which the reference, control amplifier, and current array are inactive and the DAC supply current is reduced to  $1\mu\text{A}$ . To enter this mode, connect PD to  $\text{DV}_{\text{DD}}$ . To return to active mode, connect PD to DGND and DACEN to  $\text{DV}_{\text{DD}}$ . Table 1 lists the power-down mode selection. About  $50\mu\text{s}$  are required for the parts to leave shutdown mode and settle to their outputs' values prior to shutdown.

## Timing Information

Both DAC cells in the MAX5180/MAX5183 write to their outputs simultaneously (Figure 4). The input latch of the first DAC (DAC1) is loaded after the clock signal transitions high. When the clock signal transitions low, the input latch of the second DAC (DAC2) is loaded. Simultaneously at the rising edge of the next clock, the contents of both input latches are shifted to the DAC registers and their outputs are updated.

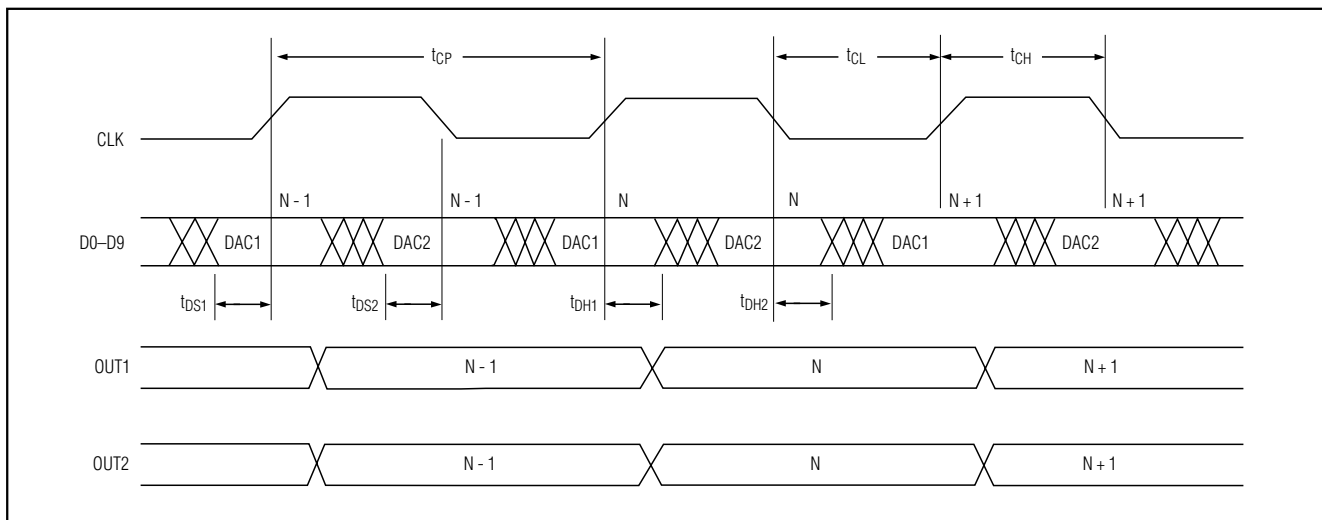

Figure 4. Timing Diagram

Table 1. Power-Down Mode Selection

PD (POWER-DOWN SELECT)	DACEN (DAC ENABLE)	POWER-DOWN MODE	OUTPUT STATE	
0	0	Standby	MAX5180	High-Z
			MAX5183	AGND
0	1	Wake-Up	Last state prior to standby mode	
1	X	Shutdown	MAX5180	High-Z
			MAX5183	AGND

X = Don't care

# Dual, 10-Bit, 40MHz, Current/Voltage Simultaneous-Output DACs

## Outputs

The MAX5180 outputs are designed to supply full-scale output currents of 1mA into 400Ω loads in parallel with a capacitive load of 5pF. The MAX5183 features integrated 400Ω resistors that restore the array currents to proportional, differential voltages of 400mV. These differential output voltages can then be used to drive a balun transformer or a low-distortion, high-speed operational amplifier to convert the differential voltage into a single-ended voltage.

## Applications Information

### Static and Dynamic Performance Definitions

#### Integral Nonlinearity

Integral nonlinearity (INL) (Figure 5a) is the deviation of the values on an actual transfer function from either a best-straight-line fit (closest approximation to the actual

transfer curve) or a line drawn between the endpoints of the transfer function once offset and gain errors have been nullified. For a DAC, the deviations are measured every single step.

#### Differential Nonlinearity

Differential nonlinearity (DNL) (Figure 5b) is the difference between an actual step height and the ideal value of 1LSB. A DNL error specification of less than 1LSB guarantees no missing codes and a monotonic transfer function.

#### Offset Error

Offset error (Figure 5c) is the difference between the ideal and the actual offset point. For a DAC, the offset point is the step value when the digital input is zero. This error affects all codes by the same amount and can usually be compensated by trimming.

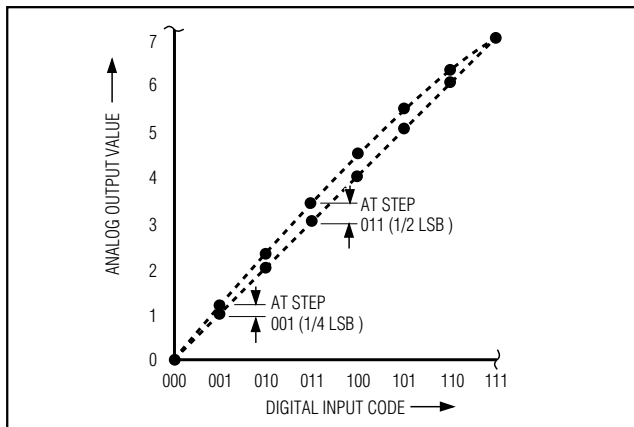

Figure 5a. Integral Nonlinearity

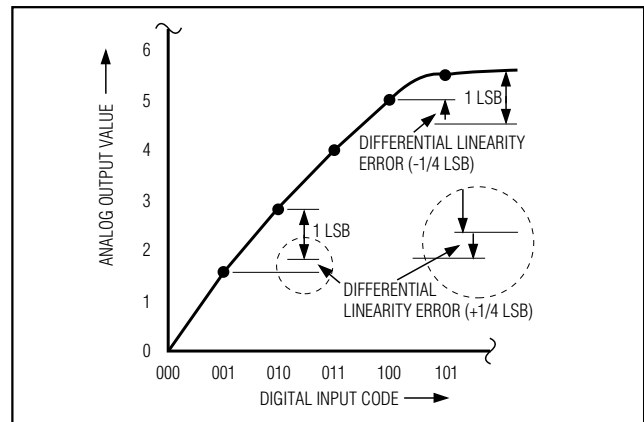

Figure 5b. Differential Nonlinearity

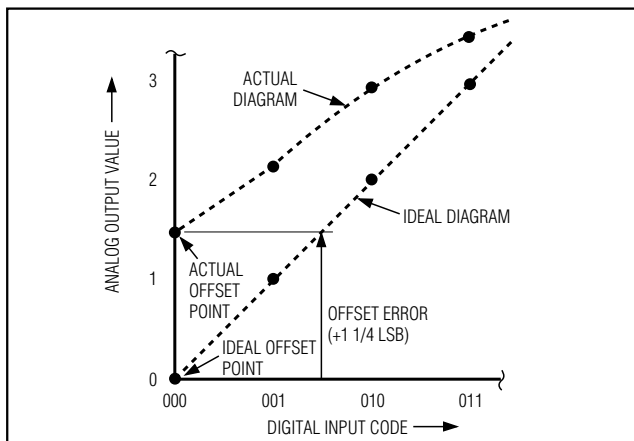

Figure 5c. Offset Error

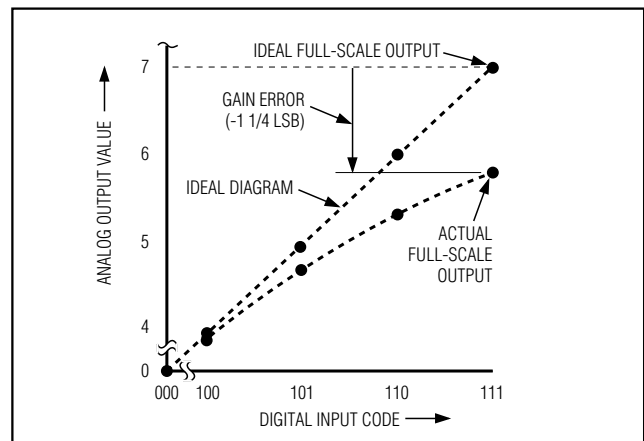

Figure 5d. Gain Error

## Dual, 10-Bit, 40MHz, Current/Voltage Simultaneous-Output DACs

### Gain Error

Gain error (Figure 5d) is the difference between the ideal and the actual full-scale output voltage on the transfer curve after nullifying the offset error. This error alters the slope of the transfer function and corresponds to the same percentage error in each step.

### Settling Time

Settling time is the amount of time required from the start of a transition until the DAC output settles its new output value to within the converter's specified accuracy.

### Digital Feedthrough

Digital feedthrough is the noise generated on a DAC's output when any digital input transitions. Proper board layout and grounding will significantly reduce this noise, but there will always be some feedthrough caused by the DAC itself.

### Total Harmonic Distortion

Total harmonic distortion (THD) is the ratio of the RMS sum of the input signal's first five harmonics to the fundamental itself. This is expressed as:

$$\text{THD} = 20 \cdot \log \left( \frac{\sqrt{V_2^2 + V_3^2 + V_4^2 + V_5^2}}{V_1} \right)$$

where  $V_1$  is the fundamental amplitude, and  $V_2$  through  $V_5$  are the amplitudes of the 2nd- through 5th-order harmonics.

### Spurious-Free Dynamic Range

Spurious-free dynamic range (SFDR) is the ratio of RMS amplitude of the fundamental (maximum signal component) to the RMS value of the next-largest distortion component.

### Differential to Single-Ended Conversion

The MAX4108 low-distortion, high-input bandwidth amplifier may be used to generate a voltage from the array current output of the MAX5180. The differential voltage across OUT1P (or OUT2P) and OUT1N (or OUT2N) is converted into a single-ended voltage by designing an appropriate operational amplifier configuration (Figure 6).

### I/Q Reconstruction in a QAM Application

The MAX5180/MAX5183's low-distortion supports analog reconstruction of in-phase (I) and quadrature (Q) carrier components typically used in QAM (quadrature

amplitude modulation) architectures where I and Q data are interleaved on a common data bus. A QAM signal is a carrier frequency that is both amplitude and phase modulated, and is created by summing two independently modulated carriers of identical frequency but different phase (90° phase difference).

In a typical QAM application (Figure 7), the modulation occurs in the digital domain and the MAX5180/MAX5183's dual DACs may be used to reconstruct the analog I and Q components.

The I/Q reconstruction system is completed by a quadrature modulator that combines the reconstructed I and Q components with in-phase and quadrature phase carrier frequencies, then sums both outputs to provide the QAM signal.

### Grounding and Power-Supply Decoupling

Grounding and power-supply decoupling strongly influence the MAX5180/MAX5183's performance. Unwanted digital crosstalk may couple through the input, reference, power-supply, and ground connections, which may affect dynamic specifications like signal-to-noise ratio or spurious-free dynamic range. In addition, electromagnetic interference (EMI) can either couple into or be generated by the MAX5180/MAX5183. Therefore, grounding and power-supply decoupling guidelines for high-speed, high-frequency applications should be closely followed.

First, a multilayer pc board with separate ground and power-supply planes is recommended. High-speed signals should be run on controlled impedance lines directly above the ground plane. Since the MAX5180/MAX5183 have separate analog and digital ground buses (AGND and DGND, respectively), the PC board should also have separate analog and digital ground sections with only one point connecting the two. Digital signals should run above the digital ground plane, and analog signals should run above the analog ground plane.

Both devices have two power-supply inputs: analog  $V_{DD}$  ( $AV_{DD}$ ) and digital  $V_{DD}$  ( $DV_{DD}$ ). Each  $AV_{DD}$  input should be decoupled with parallel 10 $\mu$ F and 0.1 $\mu$ F ceramic-chip capacitors. These capacitors should be as close to the pin as possible, and their opposite ends should be as close to the ground plane as possible. The  $DV_{DD}$  pins should also have separate 10 $\mu$ F and 0.1 $\mu$ F capacitors adjacent to their respective pins. Try to minimize analog load capacitance for proper operation. For best performance, it is recommended to bypass CREF1 and CREF2 with low-ESR 0.1 $\mu$ F capacitors to  $AV_{DD}$ .

## Dual, 10-Bit, 40MHz, Current/Voltage Simultaneous-Output DACs

**MAX5180/MAX5183**

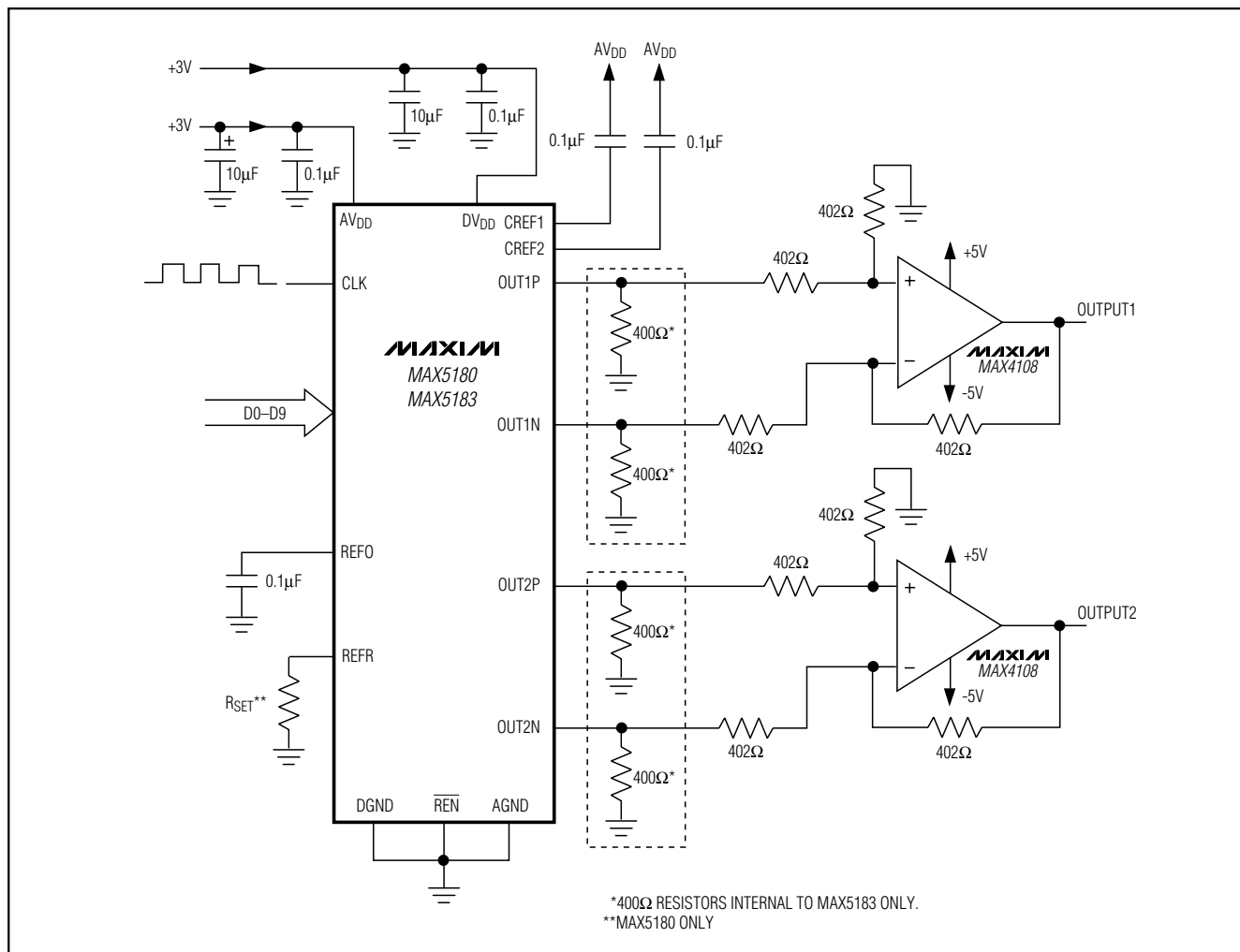

Figure 6. Differential to Single-Ended Conversion Using a Low-Distortion Amplifier

The power-supply voltages should also be decoupled with large tantalum or electrolytic capacitors at the point they enter the PC board. Ferrite beads with additional decoupling capacitors forming a pi network can also improve performance.

### Chip Information

TRANSISTOR COUNT: 9464

SUBSTRATE CONNECTED TO AGND

# Dual, 10-Bit, 40MHz, Current/Voltage Simultaneous-Output DACs

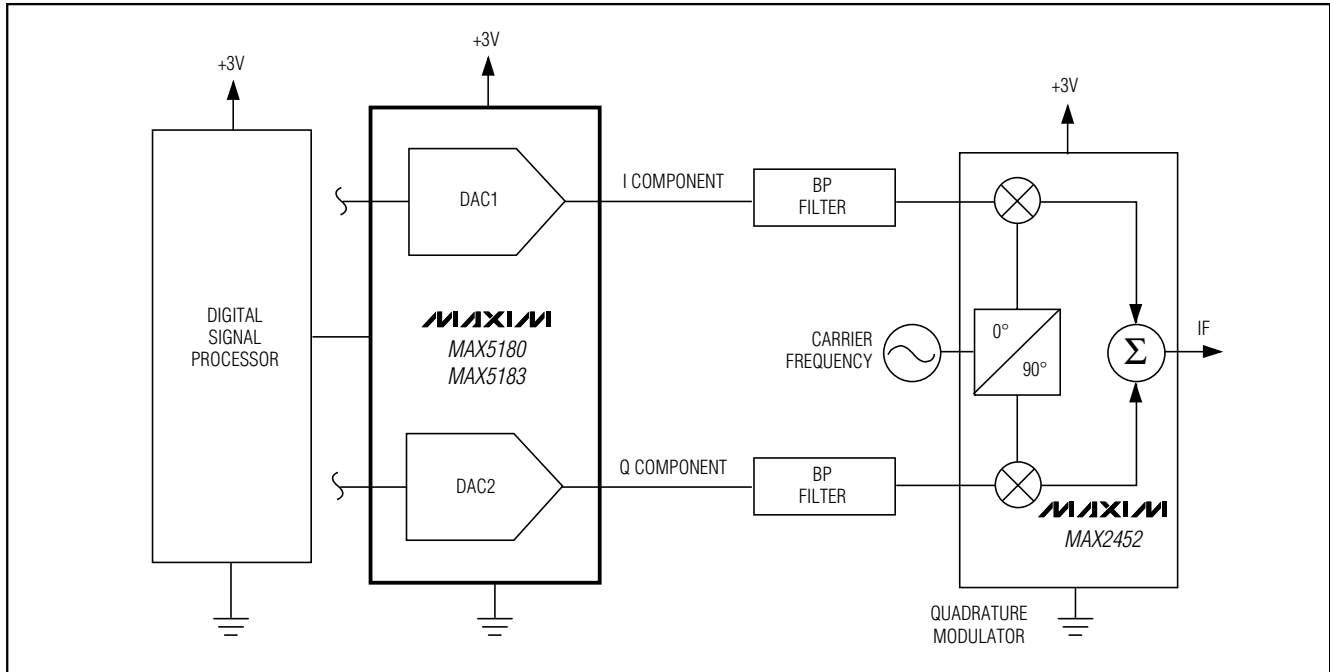

Figure 7. Using the MAX5180/MAX5183 for I/Q Signal Reconstruction

# Dual, 10-Bit, 40MHz, Current/Voltage Simultaneous-Output DACs

## Package Information

MAX5180/MAX5183

QSOP-EPS

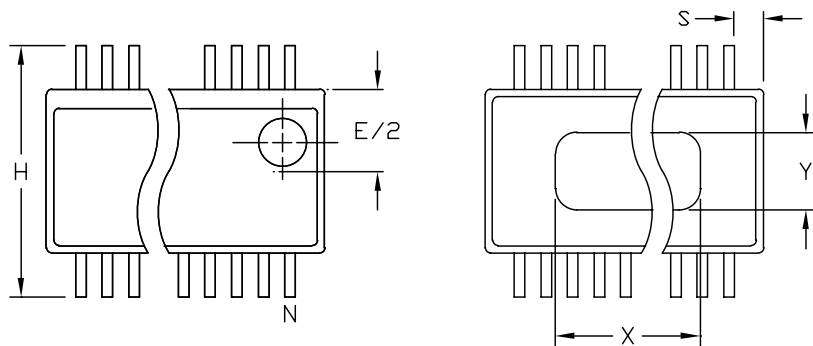

DIM	INCHES		MILLIMETERS	
	MIN	MAX	MIN	MAX
A	.061	.068	1.55	1.73
A1	.004	.0098	0.102	0.249
A2	.055	.061	1.40	1.55
B	.008	.012	0.20	0.31
C	.0075	.0098	0.191	0.249
D	SEE VARIATIONS			
E	.150	.157	3.81	3.99
e	.025 BSC		0.635 BSC	
H	.230	.244	5.84	6.20
h	.010	.016	0.25	0.41
L	.016	.035	0.41	0.89
N	SEE VARIATIONS			
X	SEE VARIATIONS			
Y	.071	.087	1.803	2.209
α	0°	8°	0°	8°

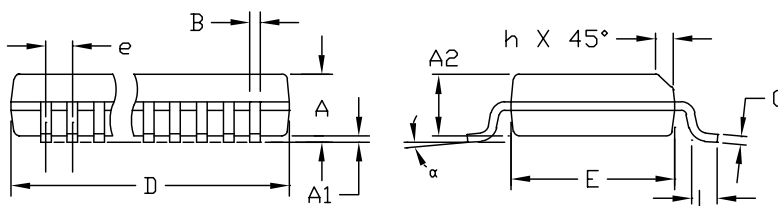

### VARIATIONS:

DIM	INCHES		MILLIMETERS		N
	MIN.	MAX.	MIN.	MAX.	
D	.189	.196	4.80	4.98	16   AA
S	.0020	.0070	0.05	0.18	
X	.107	.123	2.72	3.12	
D	.337	.344	8.56	8.74	20   AB
S	.0500	.0550	1.270	1.397	
D	.337	.344	8.56	8.74	24   AC
S	.0250	.0300	0.635	0.762	
D	.386	.393	9.80	9.98	28   AD
S	.0250	.0300	0.635	0.762	
X	.271	.287	6.88	7.29	

### NOTES:

1. D & E DO NOT INCLUDE MOLD FLASH OR PROTRUSIONS
2. MOLD FLASH OR PROTRUSIONS NOT TO EXCEED .006" PER SIDE.
3. HEAT SLUG DIMENSIONS X AND Y APPLY ONLY TO 16 AND 28 LEAD POWER-QSOP PACKAGES.
4. CONTROLLING DIMENSIONS: INCHES.

<b>MAXIM</b>			
PROPRIETARY INFORMATION			
TITLE:			
PACKAGE OUTLINE, QSOP, .150", .025" LEAD PITCH			
APPROVAL	DOCUMENT CONTROL NO.	REV	1/1
	21-0055	B	

# **Dual, 10-Bit, 40MHz, Current/Voltage Simultaneous-Output DACs**

## **NOTES**

*Maxim cannot assume responsibility for use of any circuitry other than circuitry entirely embodied in a Maxim product. No circuit patent licenses are implied. Maxim reserves the right to change the circuitry and specifications without notice at any time.*

**16** \_\_\_\_\_ **Maxim Integrated Products, 120 San Gabriel Drive, Sunnyvale, CA 94086 408-737-7600**