



New Product

Si4948BEY  
Vishay Siliconix

## Dual P-Channel 60-V (D-S) 175° MOSFET

PRODUCT SUMMARY		
V <sub>DS</sub> (V)	r <sub>DS(on)</sub> (Ω)	I <sub>D</sub> (A)
-60	0.120 @ V <sub>GS</sub> = -10 V	-3.1
	0.150 @ V <sub>GS</sub> = -4.5 V	-2.8

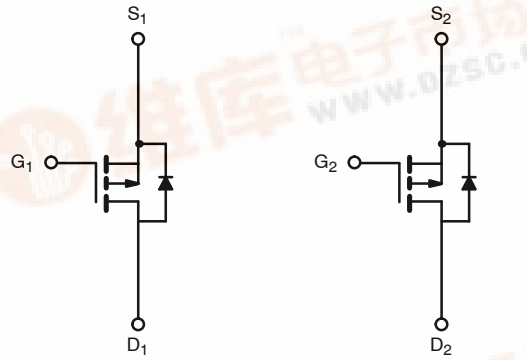
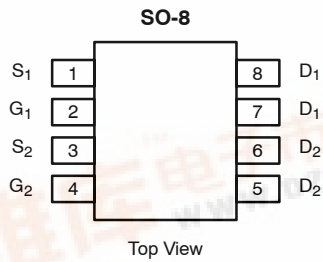

P-Channel MOSFET

P-Channel MOSFET

Ordering Information: Si4948BEY—E3 (Lead Free)  
Si4948BEY-T1—E3 (Lead Free with Tape and Reel)

ABSOLUTE MAXIMUM RATINGS (T <sub>A</sub> = 25°C UNLESS OTHERWISE NOTED)					
Parameter	Symbol	10 secs	Steady State	Unit	
Drain-Source Voltage	V <sub>DS</sub>	-60		V	
Gate-Source Voltage	V <sub>GS</sub>	±20			
Continuous Drain Current (T <sub>J</sub> = 150°C) <sup>a</sup>	I <sub>D</sub>	T <sub>A</sub> = 25°C	-3.1	-2.4	A
		T <sub>A</sub> = 70°C	-2.6	-2.0	
Pulsed Drain Current (10 μs Pulse Width)	I <sub>DM</sub>	-25			
Continuous Source Current (Diode Conduction) <sup>a</sup>	I <sub>S</sub>	-2	-1.1		
Avalanche Current	L = 0.1 mH	I <sub>AS</sub>	15		
Single Pulse Avalanche Energy			E <sub>AS</sub>	11	
Maximum Power Dissipation <sup>a</sup>	P <sub>D</sub>	T <sub>A</sub> = 25°C	2.4	1.4	W
		T <sub>A</sub> = 70°C	1.7	0.95	
Operating Junction and Storage Temperature Range	T <sub>J</sub> , T <sub>stg</sub>	-55 to 175		°C	

THERMAL RESISTANCE RATINGS					
Parameter	Symbol	Typical	Maximum	Unit	
Maximum Junction-to-Ambient <sup>a</sup>	R <sub>thJA</sub>	t ≤ 10 sec	53	62.5	°C/W
		Steady State	85	110	
Maximum Junction-to-Foot	R <sub>thJF</sub>	30	37		

Notes:  
a. Surface Mounted on 1" x 1" FR4 Board.



<b>SPECIFICATIONS (T<sub>J</sub> = 25 °C UNLESS OTHERWISE NOTED)</b>						
Parameter	Symbol	Test Condition	Min	Typ	Max	Unit
<b>Static</b>						
Gate Threshold Voltage	V <sub>GS(th)</sub>	V <sub>DS</sub> = V <sub>GS</sub> , I <sub>D</sub> = -250 μA	-1		-3	V
Gate-Body Leakage	I <sub>GSS</sub>	V <sub>DS</sub> = 0 V, V <sub>GS</sub> = ±20 V			±100	nA
Zero Gate Voltage Drain Current	I <sub>DSS</sub>	V <sub>DS</sub> = -60 V, V <sub>GS</sub> = 0 V			-1	μA
		V <sub>DS</sub> = -60 V, V <sub>GS</sub> = 0 V, T <sub>J</sub> = 70 °C			-10	
On-State Drain Current <sup>a</sup>	I <sub>D(on)</sub>	V <sub>DS</sub> = -5 V, V <sub>GS</sub> = -10 V	-25			A
Drain-Source On-State Resistance <sup>a</sup>	r <sub>DS(on)</sub>	V <sub>GS</sub> = -10 V, I <sub>D</sub> = -3.1 A		0.100	0.120	Ω
		V <sub>GS</sub> = -4.5 V, I <sub>D</sub> = -0.2 A		0.126	0.150	
Forward Transconductance <sup>a</sup>	g <sub>fs</sub>	V <sub>DS</sub> = -15 V, I <sub>D</sub> = -3.1 A		8.5		S
Diode Forward Voltage <sup>a</sup>	V <sub>SD</sub>	I <sub>S</sub> = -2 A, V <sub>GS</sub> = 0 V		-0.8	-1.2	V
<b>Dynamic<sup>b</sup></b>						
Total Gate Charge	Q <sub>g</sub>	V <sub>DS</sub> = -30 V, V <sub>GS</sub> = -10 V, I <sub>D</sub> = -3.1 A		14.5	22	nC
Gate-Source Charge	Q <sub>gs</sub>			2.2		
Gate-Drain Charge	Q <sub>gd</sub>			3.7		
Gate Resistance	R <sub>g</sub>	f = 1 MHz		14		Ω
Turn-On Delay Time	t <sub>d(on)</sub>	V <sub>DD</sub> = -30 V, R <sub>L</sub> = 30 Ω I <sub>D</sub> ≅ -1 A, V <sub>GEN</sub> = -10 V, R <sub>g</sub> = 6 Ω		10	15	ns
Rise Time	t <sub>r</sub>			15	22	
Turn-Off Delay Time	t <sub>d(off)</sub>			50	75	
Fall Time	t <sub>f</sub>			35	55	
Source-Drain Reverse Recovery Time	t <sub>rr</sub>	I <sub>F</sub> = -2 A, di/dt = 100 A/μs		30	50	

**Notes**

- a. Pulse test; pulse width ≤ 300 μs, duty cycle ≤ 2%.
- b. Guaranteed by design, not subject to production testing.

**TYPICAL CHARACTERISTICS (25 °C UNLESS NOTED)**

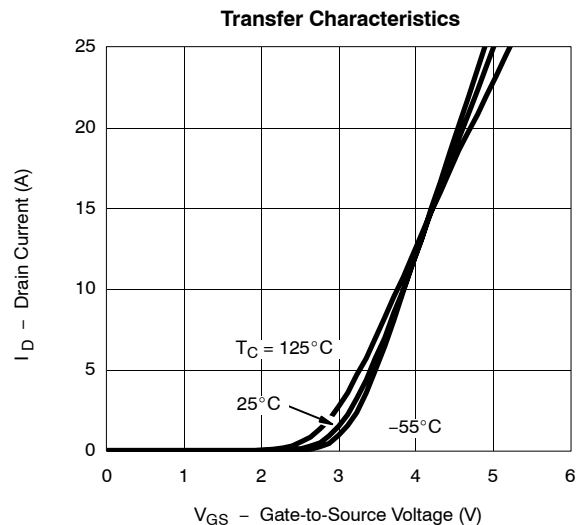
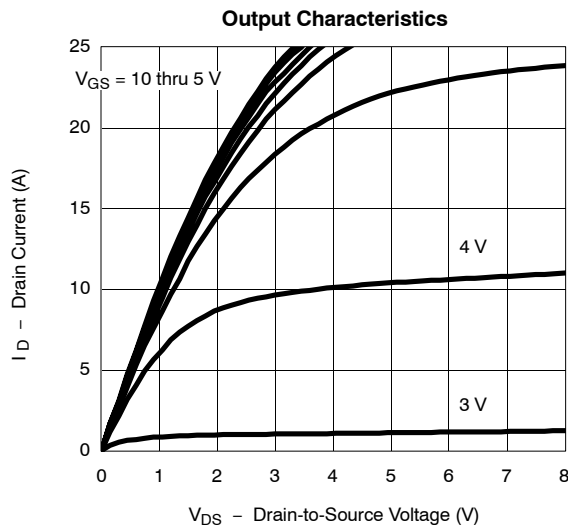



New Product

Si4948BEY  
Vishay Siliconix

**TYPICAL CHARACTERISTICS (25°C UNLESS NOTED)**

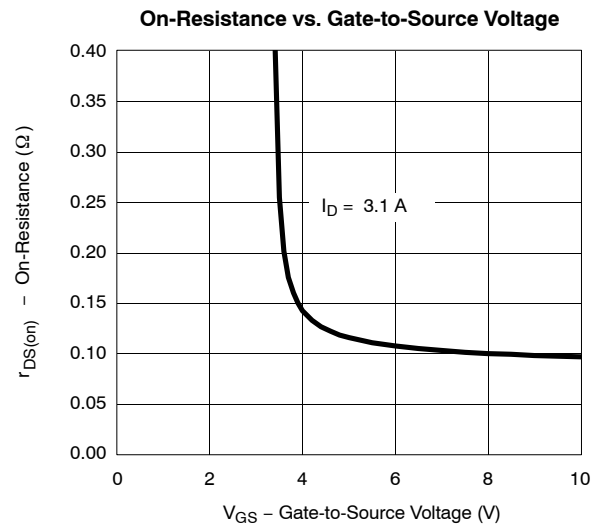
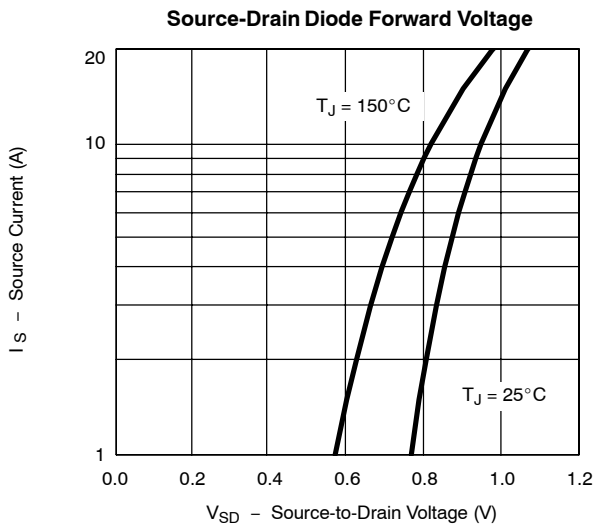
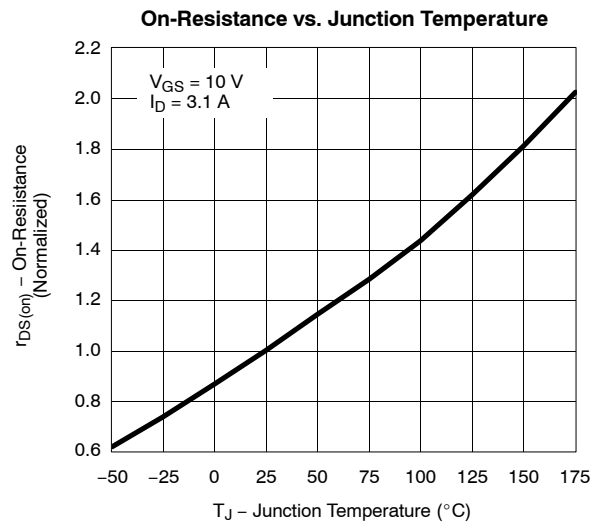
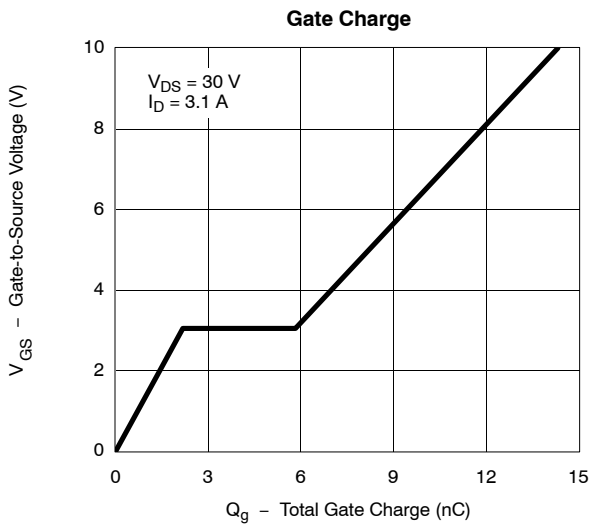
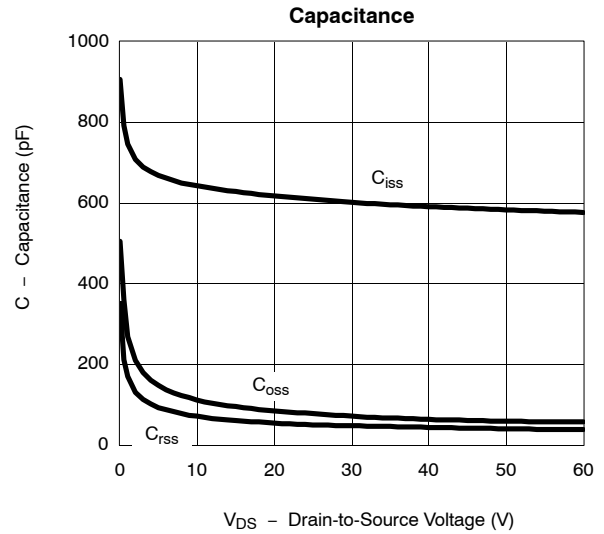
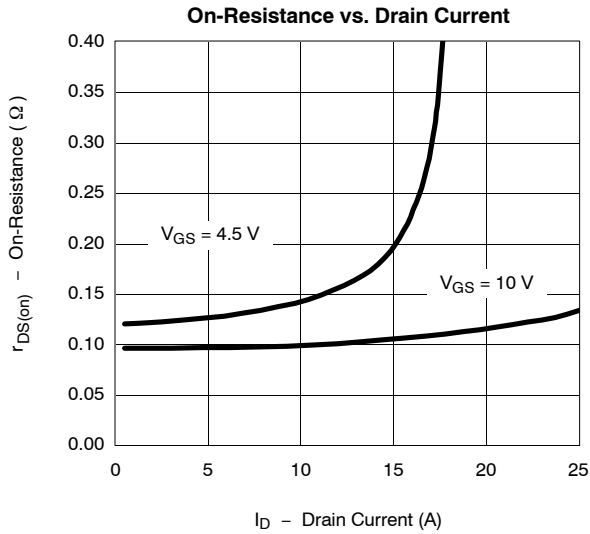



**TYPICAL CHARACTERISTICS (25 °C UNLESS NOTED)**

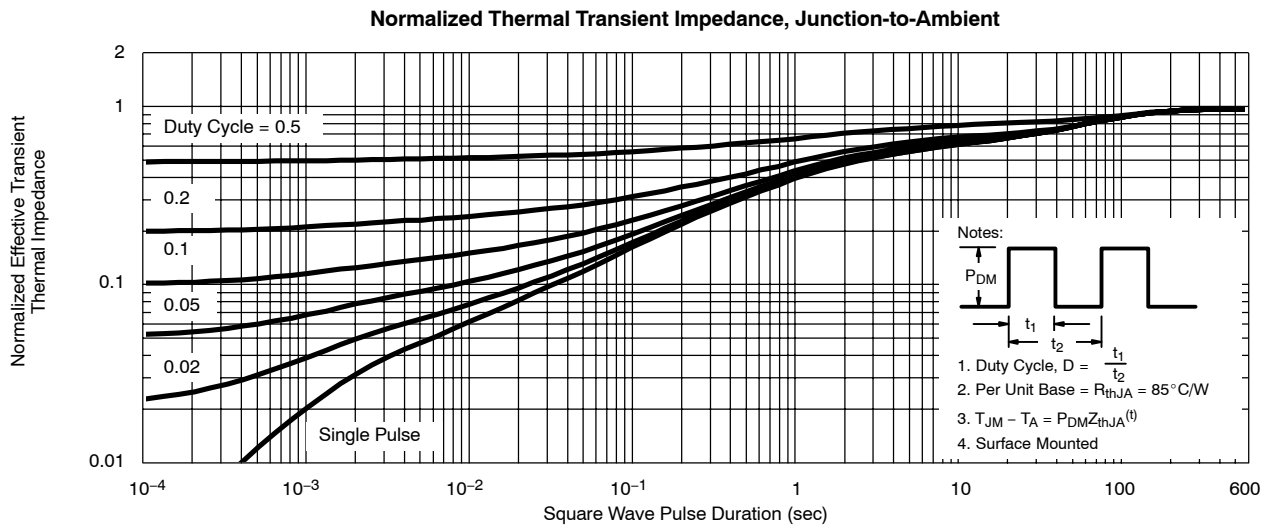
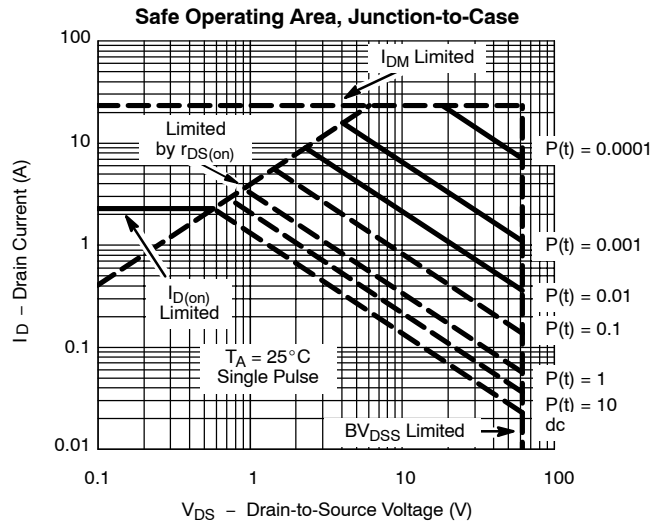
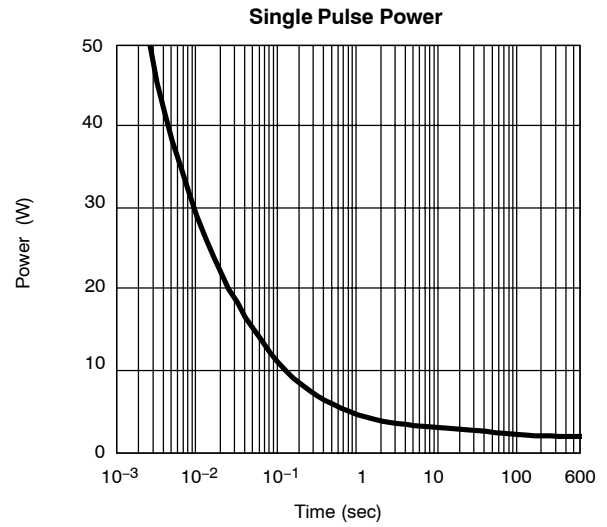
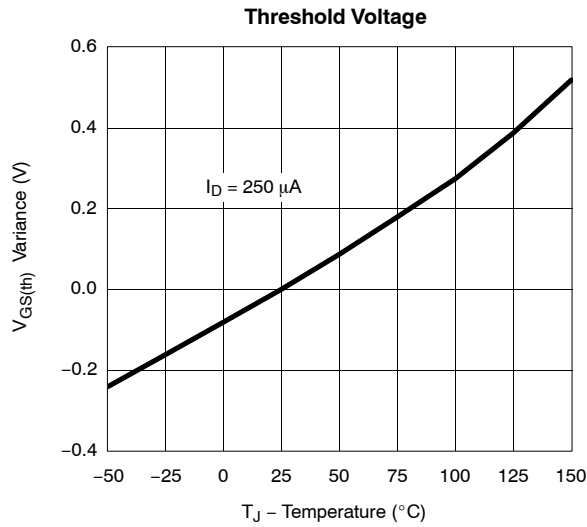



New Product

Si4948BEY  
Vishay Siliconix

**TYPICAL CHARACTERISTICS (25°C UNLESS NOTED)**

