

NPN Silicon RF Transistor

- For amplifier and oscillator applications in TV-tuners

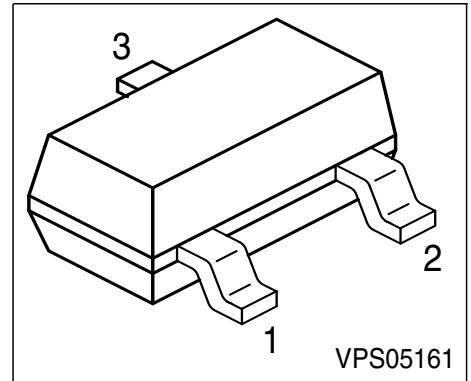

Type	Marking	Pin Configuration			Package
BF 517	LRs	1 = B	2 = E	3 = C	SOT-23

Maximum Ratings

Parameter	Symbol	Value	Unit
Collector-emitter voltage	V_{CEO}	15	V
Collector-base voltage	V_{CBO}	20	
Emitter-base voltage	V_{EBO}	2.5	
Collector current	I_C	25	mA
Peak collector current, $f \geq 10$ MHz	I_{CM}	50	
Total power dissipation, $T_S \leq 55$ °C ^{F)}	P_{tot}	280	mW
Junction temperature	T_j	150	°C
Ambient temperature	T_A	-65 ... 150	
Storage temperature	T_{stg}	-65 ... 150	

Thermal Resistance

Junction - soldering point	R_{thJS}	≤ 340	K/W
----------------------------	------------	------------	-----

¹ T_S is measured on the collector lead at the soldering point to the pcb

Electrical Characteristics at $T_A = 25\text{ }^\circ\text{C}$, unless otherwise specified.

Parameter	Symbol	Values			Unit
		min.	typ.	max.	
DC characteristics					
Collector-emitter breakdown voltage $I_C = 1\text{ mA}, I_B = 0$	$V_{(BR)CEO}$	15	-	-	V
Collector-base cutoff current $V_{CB} = 15\text{ V}, I_E = 0$	I_{CBO}	-	-	50	nA
DC current gain $I_C = 5\text{ mA}, V_{CE} = 10\text{ V}$	h_{FE}	25	-	250	-
Collector-emitter saturation voltage $I_C = 10\text{ mA}, I_B = 1\text{ mA}$	V_{CEsat}	-	0.1	0.5	V
AC characteristics					
Transition frequency $I_C = 5\text{ mA}, V_{CE} = 10\text{ V}, f = 200\text{ MHz}$	f_T	1	2	-	GHz
Collector-base capacitance $V_{CB} = 5\text{ V}, f = 1\text{ MHz}$	C_{cb}	0.3	0.55	0.75	pF
Collector-emitter capacitance $V_{CE} = 5\text{ V}, f = 1\text{ MHz}$	C_{ce}	-	0.25	0.4	
Input capacitance $V_{EB} = 0.5\text{ V}, I_C = 0, f = 1\text{ MHz}$	C_{ibo}	-	1.45	-	
Output capacitance $V_{CE} = 5\text{ V}, V_{BE} = 0, f = 1\text{ MHz}$	C_{obs}	-	0.8	-	
Noise figure $I_C = 5\text{ mA}, V_{CE} = 10\text{ V}, f = 100\text{ MHz},$ $Z_S = 75\text{ }\Omega$	F	-	2.5	-	

Total power dissipation $P_{tot} = f(T_A^*, T_S)$

* Package mounted on epoxy

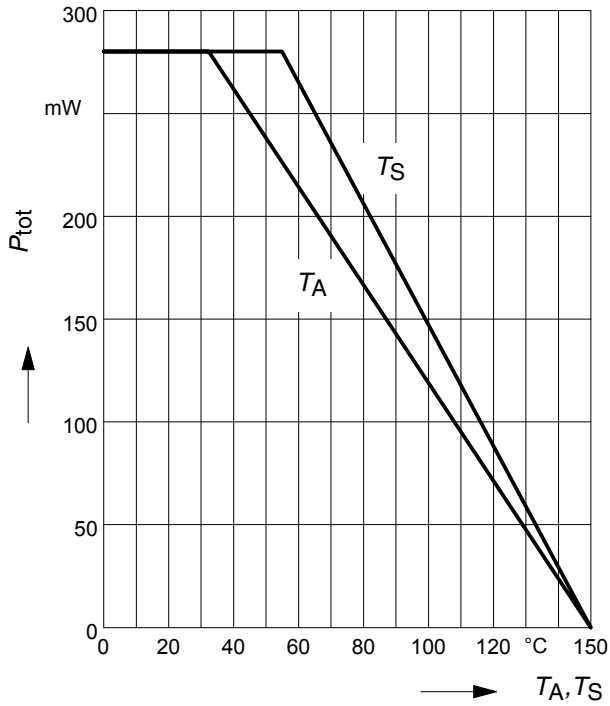

Permissible Pulse Load $R_{thJS} = f(t_p)$

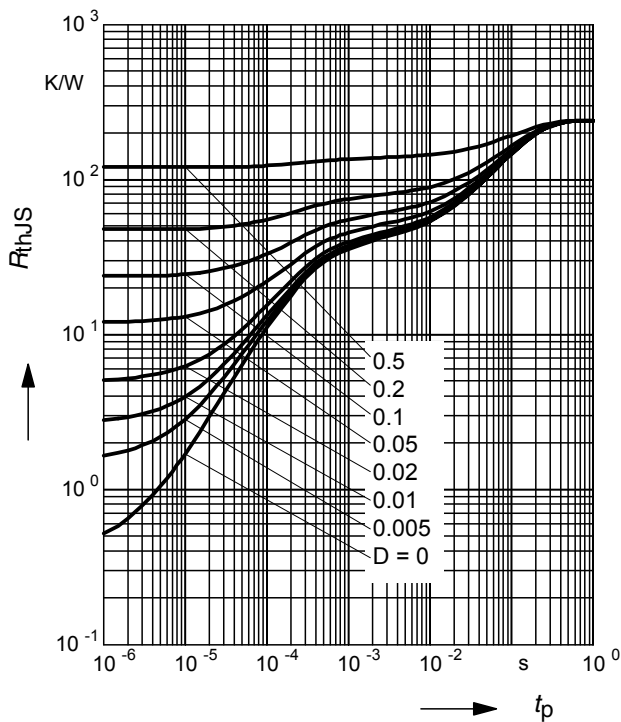

Permissible Pulse Load

$P_{totmax}/P_{totDC} = f(t_p)$

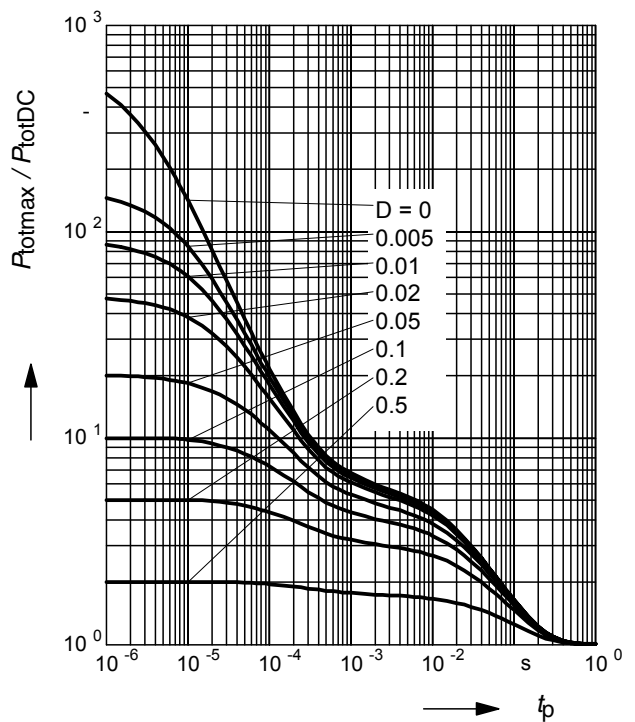

Collector-base capacitance $C_{cb} = f(V_{CB})$
 $f = 1\text{MHz}$

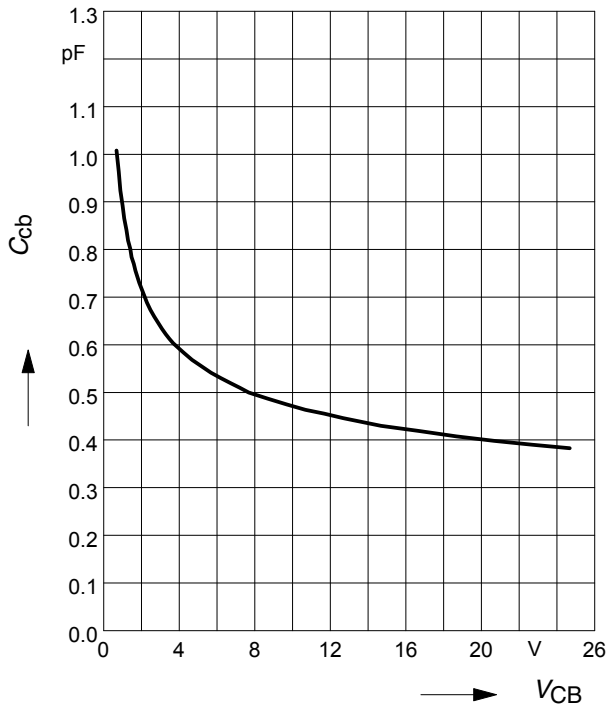

Transition frequency $f_T = f(I_C)$

$V_{CE} = \text{Parameter}$

