



**BF 883 S**

T-33-05

**Silicon NPN Epitaxial Planar RF Transistor**

Applications: Video B-class power stages in TV receivers

Features:

- High reverse voltage
- No  $h_{FE}$ -drift dependent of temperature

Dimensions in mm

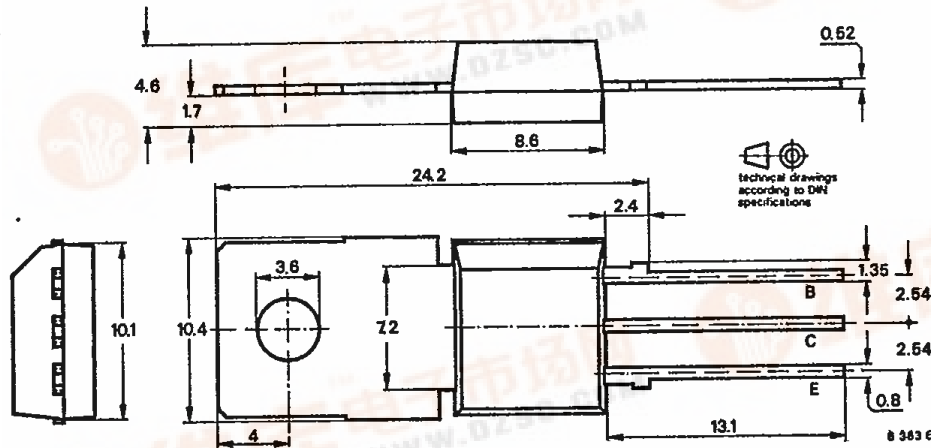

Standard plastic case  
34 A 3 DIN 41 869  
JEDEC TO 202  
Weight max. 1.8 g

Collector connected with metallic surface

Absolute maximum ratings

Collector-base voltage	$V_{CBO}$	300	V
Collector-emitter voltage	$V_{CEO}$	275	V
Emitter-base voltage	$V_{EBO}$	5	V
Collector current	$I_C$	50	mA
Collector peak current	$I_{CM}$	300	mA
Total power dissipation $T_{case} \leq 25^\circ C$	$P_{tot}$	7	W
Junction temperature	$T_j$	150	$^\circ C$
Storage temperature range	$T_{stg}$	-65 ... +150	$^\circ C$

Maximum thermal resistances

Junction ambient	$R_{thJA}$	78	K/W
Junction case	$R_{thJC}$	17.8	K/W

T1.2/820.0888 E



## BF 883 S

T-33-05

Characteristics		Min.	Typ.	Max.
$T_{amb} = 25^\circ\text{C}$ , unless otherwise specified				
Collector cut-off current				
$V_{CE} = 250\text{ V}, R_{BE} = 2.7\text{ k}\Omega$	$I_{CER}$			50 nA
$V_{CE} = 200\text{ V}, R_{BE} = 2.7\text{ k}\Omega, T_j = 150^\circ\text{C}$	$I_{CER}$			10 $\mu\text{A}$
Emitter cut-off current				
$V_{EB} = 5\text{ V}$	$I_{EBO}$			10 $\mu\text{A}$
Collector-emitter breakdown voltage				
$I_C = 1\text{ mA}$	$V_{(BR)CEO}$	275		V
$I_C = 1\text{ }\mu\text{A}, R_{BE} = 2.7\text{ k}\Omega$	$V_{(BR)CER}$	300		V
DC forward current transfer ratio				
$V_{CE} = 20\text{ V}, I_C = 25\text{ mA}$	$h_{FE}$	50		
Gain bandwidth product				
$V_{CE} = 10\text{ V}, I_C = 10\text{ mA}$	$f_T$	60	90	MHz
Feedback capacitance				
$V_{CE} = 30\text{ V}, I_C = 1\text{ mA}, f = 1\text{ MHz}$	$C_{12e}$		1.2	1.8 pF
Collector saturation RF voltage				
$I_C = 25\text{ mA}, T_j = 150^\circ\text{C}$	$V_{CEsatHF}$		20	V

**BF 883 S**

T-33-05

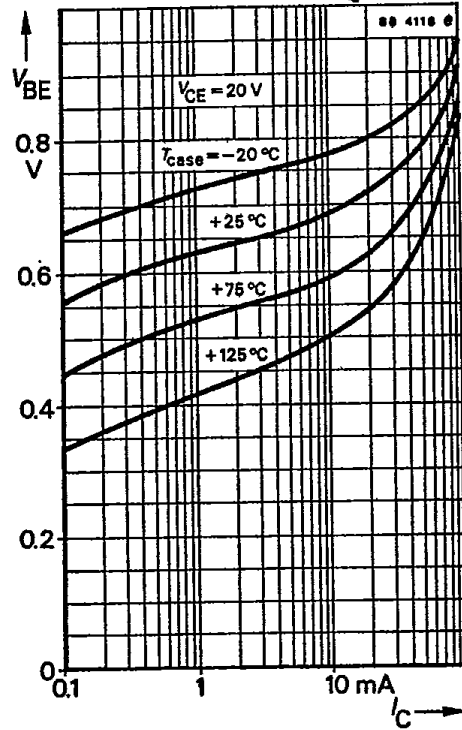
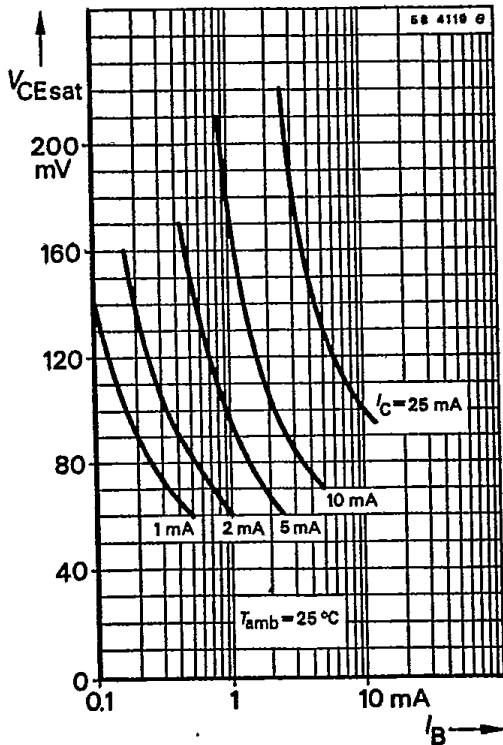
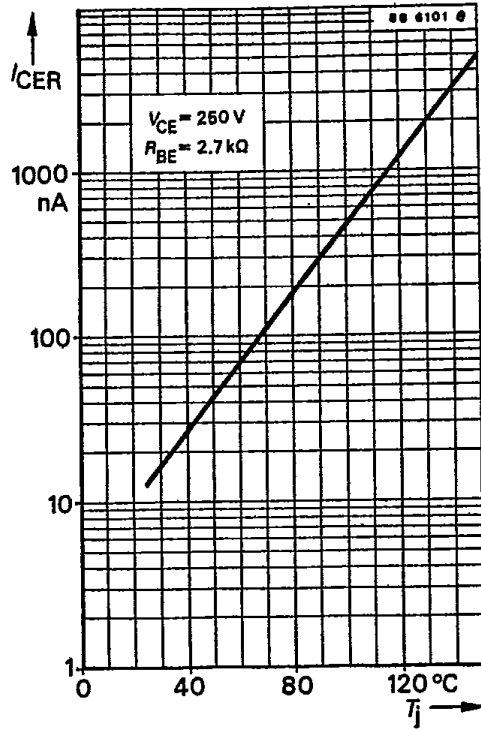
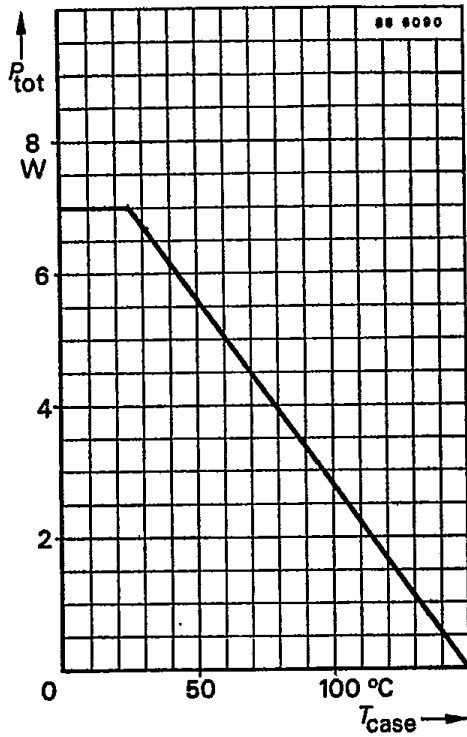

BF 883 S

T-33-05

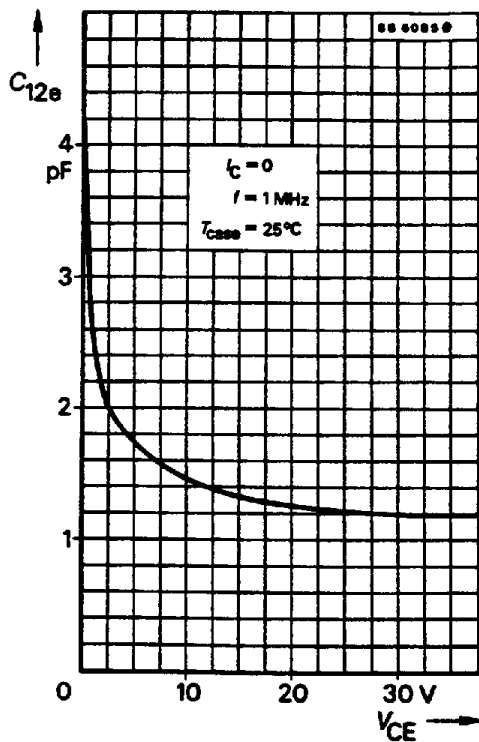
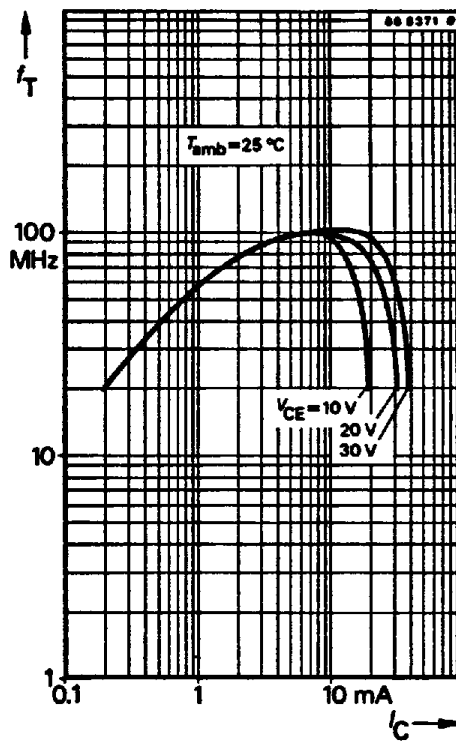
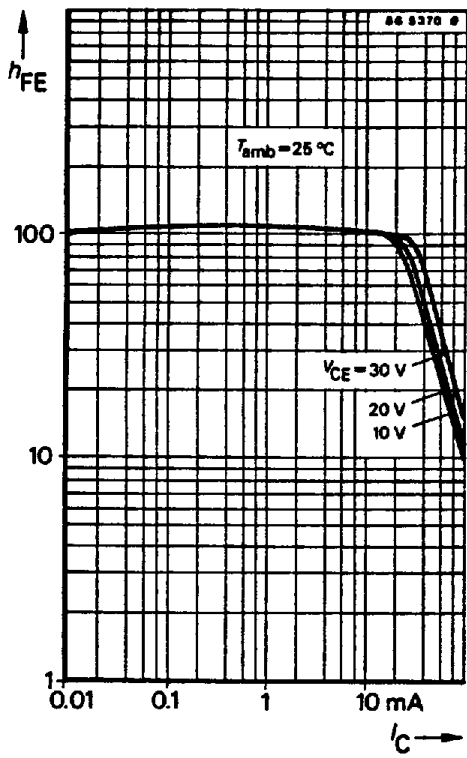

T-91-20

● Family of curves

Besides the static (d. c.) and dynamic (a. c.) characteristics, family of curves are given for specified operating conditions. They show the typical interdependence of individual characteristics. Partly are given the scattering limits. They signify that at least 95% of the delivery lies inside these tolerances.

6.6. Additional Informations

Preliminary specifications

This heading indicates that some information on the device concerned may be subject to slight changes.

Not for new developments

This heading indicates that the device concerned should not be used in equipment under development, it is, however, available for present production.

7. Taping and reeling

7.1. Taping of TO-92 transistors

Standard reeling: Taped on reel, reeled together with a paper film.

7.1.1. Order Numbers

Add the taping-code to the order number.

Example:

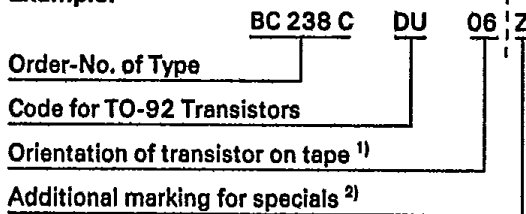

<sup>1)</sup> 06 = View on flat side of transistor, view on gummed tape

05 = View on round side of transistor, view on gummed tape

<sup>2)</sup> Additional marking "O":

Taping without paper film

Additional marking "Z":

Zigzag folded tape in special box. Marking for orientation of transistor not necessary, because box can be opened on top or bottom.

Example for order No.: BC 237 C DU Z

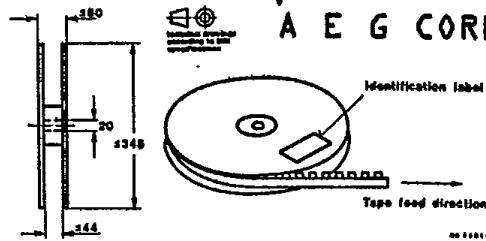

Fig. 7.1. Dimensions of reel in mm

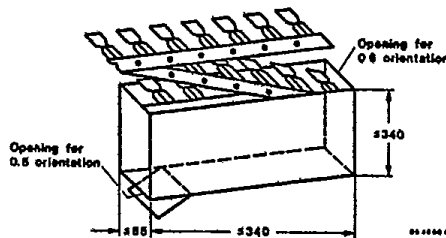

Fig. 7.2. Dimension of box for Zigzag folding in mm

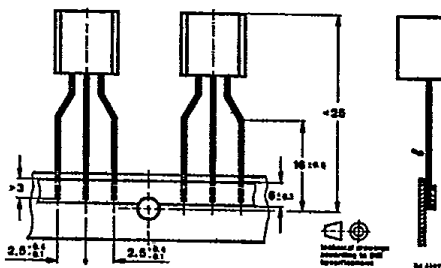

Fig. 7.3. Dimensions of tape in mm

7.1.2 Quantity of devices

1 000 devices per reel

2 000 devices per folded tape in special box.

7.2 Taped transistors in SOT 23 and SOT 143 case

a) Standard taping

Designation is attached with code GS 08 in case of standard taping. Example for normal version transistors as standard taped: BF 569-GS08.

Example for R-version transistors as standard taped: BF 569 R-GS 08.

In case of standard taping, the transistor orientation on the tape is shown in Fig. 7.4 and Fig. 7.5.

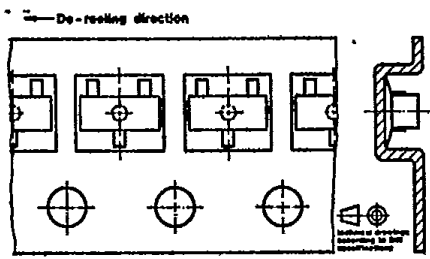

Fig. 7.4 Standard taped SOT 23

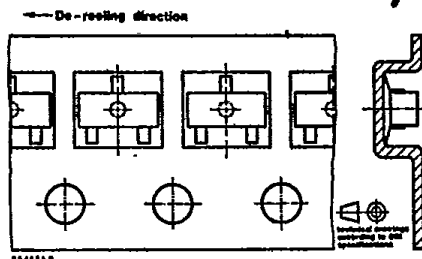

Fig. 7.6 Reverse taped SOT 23

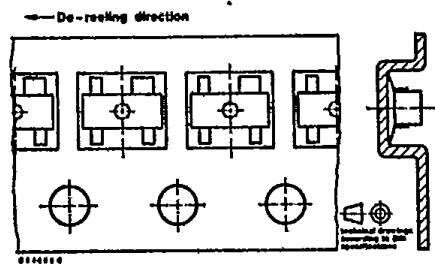

Fig. 7.5 Standard taped SOT 143

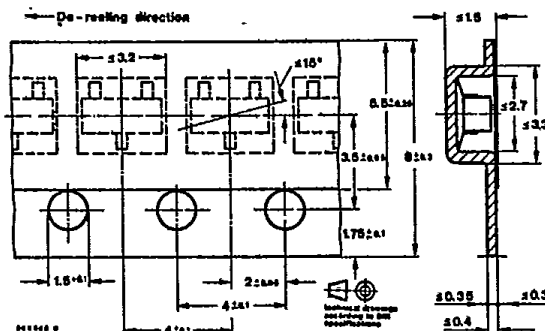

Fig. 7.7 Dimensions of tape in mm

b) Reverse taping

Designation is attached with code GS 07 in case of reverse taping. Example for normal version transistors as reverse taped: BF 569 R-GS 07. Example for R-version transistors as reverse taping: BF 569 R-GS 07.

In case of reverse taping, the transistor orientation on the tape is shown in Fig. 6. Regarding MOF-FET and MES-FET devices, reverse taping is at present not available.

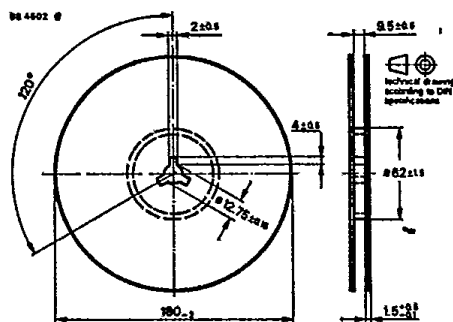

Fig. 7.8 Dimensions of reel in mm

7.2.2 Quantity of devices  
3000 devices per reel

8. Accessories

Number	Fig.	Designation	For case
119880	8.1.	Isolating washer thickness 60 $\mu$ m	12A 3 DIN 41 869 JEDEC TO 126 (SOT 32)
564542	8.2.	Isolating washer thickness 50 $\mu$ m	14A 3 DIN 41 869 JEDEC TO 220 (SOT 78)
912884	8.3	Isolating washer thickness 50 $\mu$ m	15A 3 DIN 41 869 (TOP3) for clip mounting
191131	8.4	Isolating washer thickness 50 $\mu$ m	15A 3 DIN 41 869 (TOP3) for screw mounting
191140	8.5	Mounting clip	15A 3 DIN 41 869 (TOP3)
569524	8.6	Isolating washer thickness 100 $\mu$ m + 50 $\mu$ m	3B 2 DIN 41 872 JEDEC TO 3 Devices with high reverse voltage