

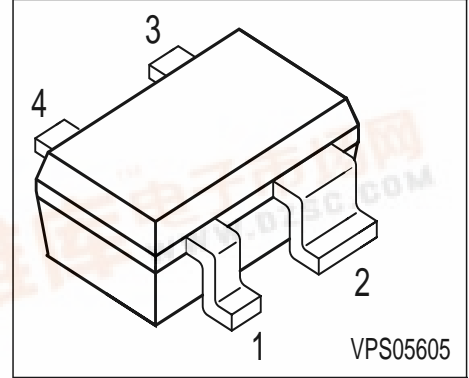

**SIEGET® 25 BFP405**

**NPN Silicon RF Transistor**

- For low current applications
- For oscillators up to 12 GHz
- Noise figure  $F = 1.25$  dB at 1.8 GHz  
outstanding  $G_{ms} = 23$  dB at 1.8 GHz
- Transition frequency  $f_T = 25$  GHz
- Gold metallization for high reliability
- **SIEGET® 25 GHz  $f_T$  - Line**



**ESD:** Electrostatic discharge sensitive device, observe handling precaution!

Type	Marking	Pin Configuration				Package
BFP405	ALs	1=B	2=E	3=C	4=E	SOT343

**Maximum Ratings**

Parameter	Symbol	Value	Unit
Collector-emitter voltage	$V_{CEO}$	4.5	V
Collector-base voltage	$V_{CBO}$	15	
Emitter-base voltage	$V_{EBO}$	1.5	
Collector current	$I_C$	12	mA
Base current	$I_B$	1	
Total power dissipation $T_S \leq 120^\circ\text{C}^1)$	$P_{tot}$	55	mW
Junction temperature	$T_j$	150	$^\circ\text{C}$
Ambient temperature	$T_A$	-65 ... 150	
Storage temperature	$T_{stg}$	-65 ... 150	

**Thermal Resistance**

Junction - soldering point <sup>2)</sup>	$R_{thJS}$	$\leq 520$	K/W
--	------------	------------	-----

<sup>1</sup>  $T_S$  is measured on the emitter lead at the soldering point to the pcb

<sup>2</sup> For calculation of  $R_{thJA}$  please refer to Application Note Thermal Resistance



**Electrical Characteristics** at  $T_A = 25^\circ\text{C}$ , unless otherwise specified.

Parameter	Symbol	Values			Unit
		min.	typ.	max.	
<b>DC characteristics</b>					
Collector-emitter breakdown voltage $I_C = 1 \text{ mA}, I_B = 0$	$V_{(BR)CEO}$	4.5	5	-	V
Collector-base cutoff current $V_{CB} = 5 \text{ V}, I_E = 0$	$I_{CBO}$	-	-	150	nA
Emitter-base cutoff current $V_{EB} = 1.5 \text{ V}, I_C = 0$	$I_{EBO}$	-	-	15	$\mu\text{A}$
DC current gain $I_C = 5 \text{ mA}, V_{CE} = 4 \text{ V}$	$h_{FE}$	50	90	150	-
<b>AC characteristics</b> (verified by random sampling)					
Transition frequency $I_C = 10 \text{ mA}, V_{CE} = 3 \text{ V}, f = 2 \text{ GHz}$	$f_T$	18	25	-	GHz
Collector-base capacitance $V_{CB} = 2 \text{ V}, f = 1 \text{ MHz}$	$C_{cb}$	-	0.05	0.1	pF
Collector-emitter capacitance $V_{CE} = 2 \text{ V}, f = 1 \text{ MHz}$	$C_{ce}$	-	0.24	-	
Emitter-base capacitance $V_{EB} = 0.5 \text{ V}, f = 1 \text{ MHz}$	$C_{eb}$	-	0.29	-	
Noise figure $I_C = 2 \text{ mA}, V_{CE} = 2 \text{ V}, Z_S = Z_{Sopt}, f = 1.8 \text{ GHz}$	$F$	-	1.25	-	dB
Power gain <sup>1)</sup> $I_C = 5 \text{ mA}, V_{CE} = 2 \text{ V}, Z_S = Z_{Sopt}, Z_L = Z_{Lopt}, f = 1.8 \text{ GHz}$	$G_{ms}$	-	23	-	
Insertion power gain $I_C = 5 \text{ mA}, V_{CE} = 2 \text{ V}, f = 1.8 \text{ MHz}, Z_S = Z_L = 50\Omega$	$ S_{21} ^2$	14	18	-	
Third order intercept point $I_C = 5 \text{ mA}, V_{CE} = 2 \text{ V}, Z_S = Z_{Sopt}, Z_L = Z_{Lopt}, f = 1.8 \text{ GHz}$	$IP_3$	-	15	-	dBm
1dB Compression point $I_C = 5 \text{ mA}, V_{CE} = 2 \text{ V}, f = 1.8 \text{ GHz}, Z_S = Z_{Sopt}, Z_L = Z_{Lopt}$	$P_{-1dB}$	-	5	-	

<sup>1)</sup> $G_{ms} = |S_{21} / S_{12}|$

**SPICE Parameters (Gummel-Poon Model, Berkley-SPICE 2G.6 Syntax) :**

**Transistor Chip Data**

IS =	0.21024	fA	BF =	83.23	-	NF =	1.0405	-
VAF =	39.251	V	IKF =	0.16493	A	ISE =	15.761	fA
NE =	1.7763	-	BR =	10.526	-	NR =	0.96647	-
VAR =	34.368	V	IKR =	0.25052	A	ISC =	0.037223	fA
NC =	1.3152	-	RB =	15	Ω	IRB =	0.21215	mA
RBM =	1.3491	Ω	RE =	1.9289		RC =	0.12691	Ω
CJE =	3.7265	fF	VJE =	0.70367	V	MJE =	0.37747	-
TF =	4.5899	ps	XTF =	0.3641	-	VTF =	0.19762	V
ITF =	1.3364	mA	PTF =	0	deg	CJC =	96.941	fF
VJC =	0.99532	V	MJC =	0.48652	-	XCJC =	0.08161	-
TR =	1.4935	ns	CJS =	0	fF	VJS =	0.75	V
MJS =	0	-	XTB =	0	-	EG =	1.11	eV
XTI =	3	-	FC =	0.99469	-	TNOM	300	K

**C'-E'-Diode Data (Berkley-SPICE 2G.6 Syntax) :**

IS =	2	fA	N =	1.02	-	RS =	20	Ω
------	---	----	-----	------	---	------	----	---

All parameters are ready to use, no scaling is necessary

**Package Equivalent Circuit:**

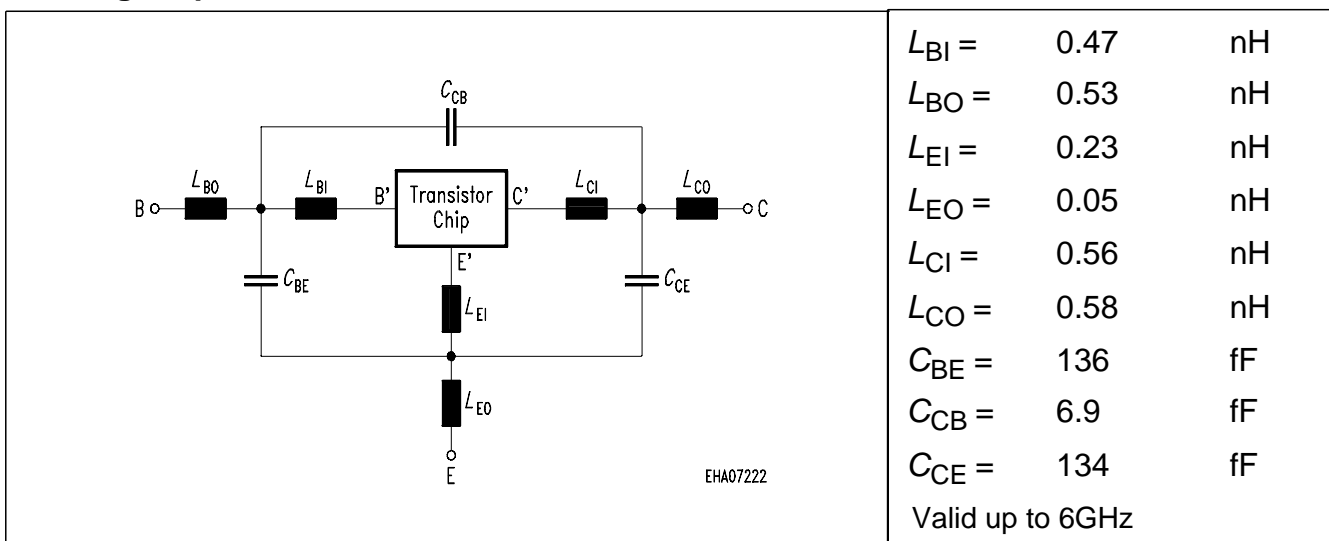

The SOT-343 package has two emitter leads. To avoid high complexity of the package equivalent circuit, both leads are combined in one electrical connection.

Extracted on behalf of Infineon Technologies AG by:  
 Institut für Mobil-und Satellitentechnik (IMST)

For examples and ready to use parameters please contact your local Infineon Technologies distributor or sales office to obtain a Infineon Technologies CD-ROM or see Internet:  
<http://www.infineon.com/silicondiscretres>

**For non-linear simulation:**

- Use transistor chip parameters in Berkeley SPICE 2G.6 syntax for all simulators.
- If you need simulation of the reverse characteristics, add the diode with the C'-E'- diode data between collector and emitter.
- Simulation of package is not necessary for frequencies < 100MHz.  
For higher frequencies add the wiring of package equivalent circuit around the non-linear transistor and diode model.

**Note:**

- This transistor is constructed in a common emitter configuration. This feature causes an additional reverse biased diode between emitter and collector, which does not effect normal operation.

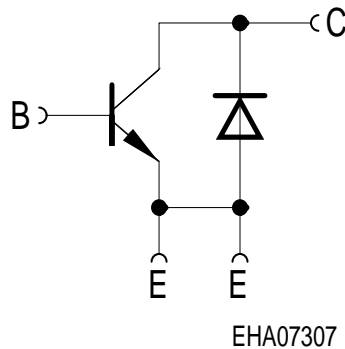

**Transistor Schematic Diagram**

The common emitter configuration shows the following advantages:

- Higher gain because of lower emitter inductance.
- Power is dissipated via the grounded emitter leads, because the chip is mounted on copper emitter leadframe.

Please note, that the broadest lead is the emitter lead.

## Common Emitter S- and Noise-parameter

For detailed S- and Noise-parameters please contact your local Infineon Technologies distributor or sales office to obtain a Infineon Technologies Application Notes CD-ROM or see Internet: <http://www.infineon.com/silicondiscretes>

Total power dissipation  $P_{tot} = f(T_S)$

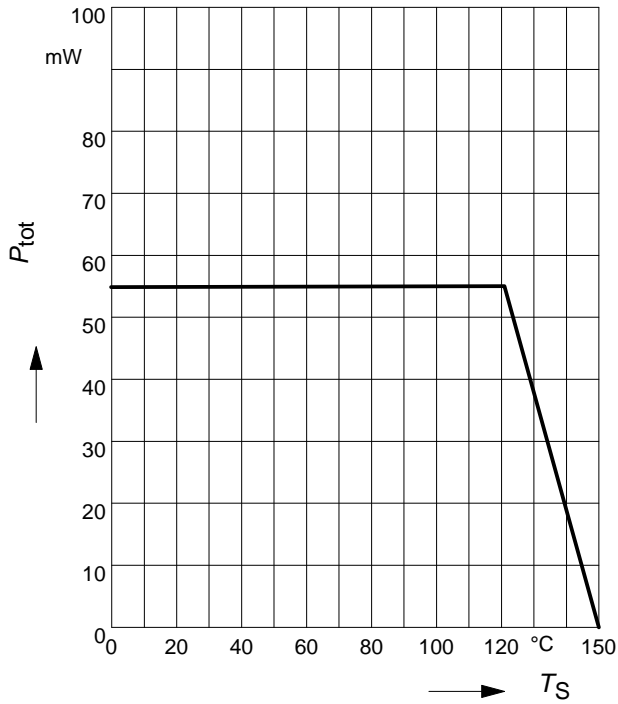

Transition frequency  $f_T = f(I_C)$

$f = 2$  GHz

$V_{CE} =$  parameter in V

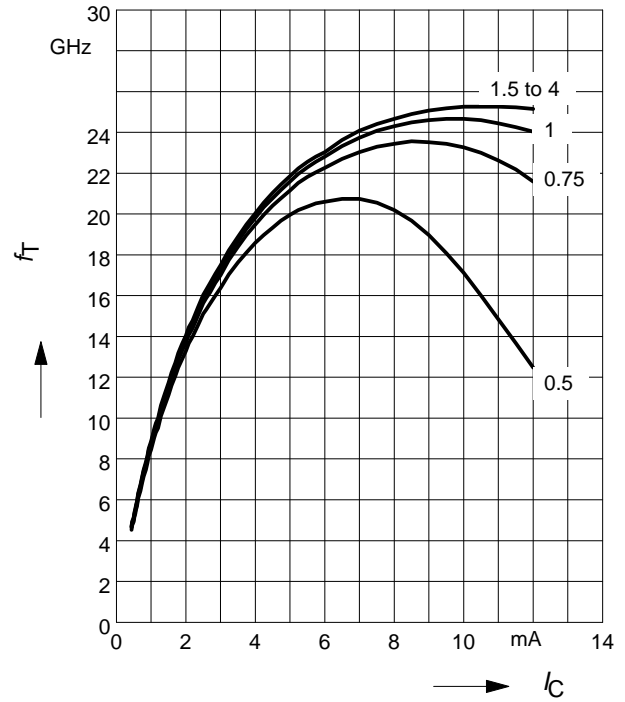

Permissible Pulse Load  $R_{thJS} = f(t_p)$

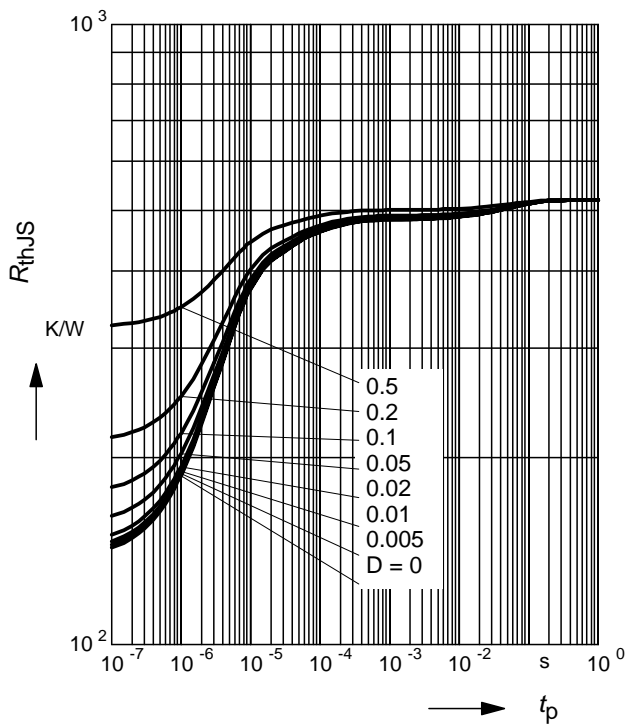

Permissible Pulse Load

$$P_{totmax}/P_{totDC} = f(t_p)$$

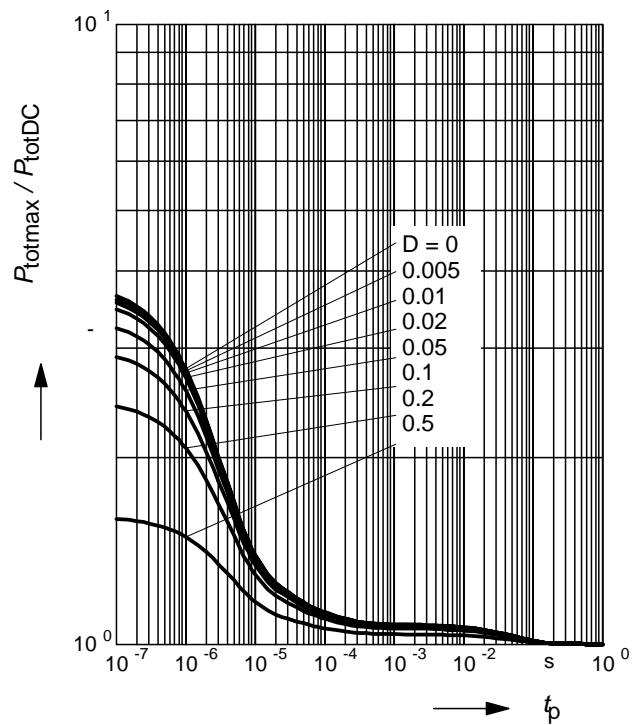

**Power gain  $G_{ma}, G_{ms}, |S_{21}|^2 = f(f)$**   
 $V_{CE} = 2\text{ V}, I_C = 5\text{ mA}$

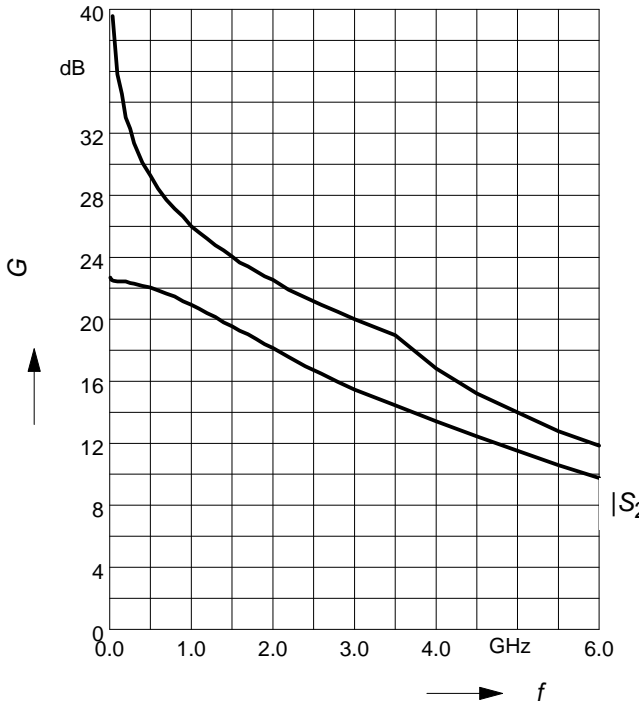

**Power gain  $G_{ma}, G_{ms} = f(I_C)$**   
 $V_{CE} = 2\text{ V}$   
 $f = \text{parameter in GHz}$

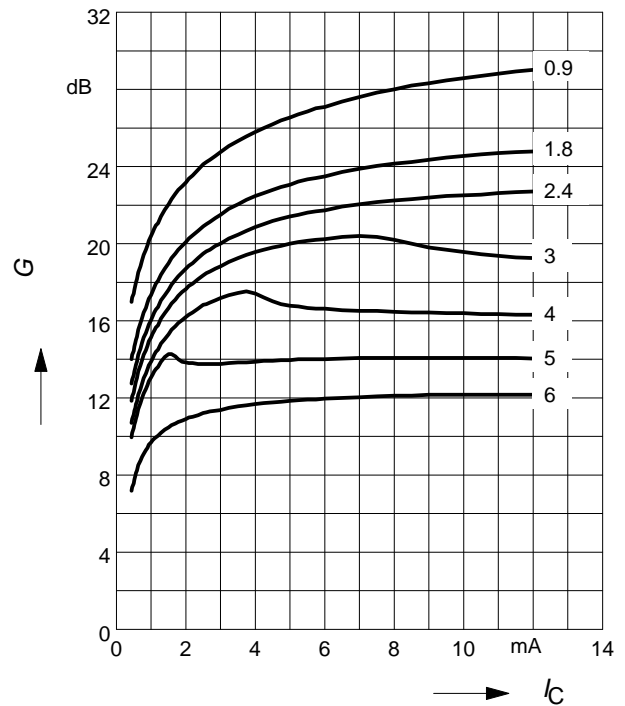

**Power gain  $G_{ma}, G_{ms} = f(V_{CE})$**   
 $I_C = 5\text{ mA}$   
 $f = \text{parameter in GHz}$

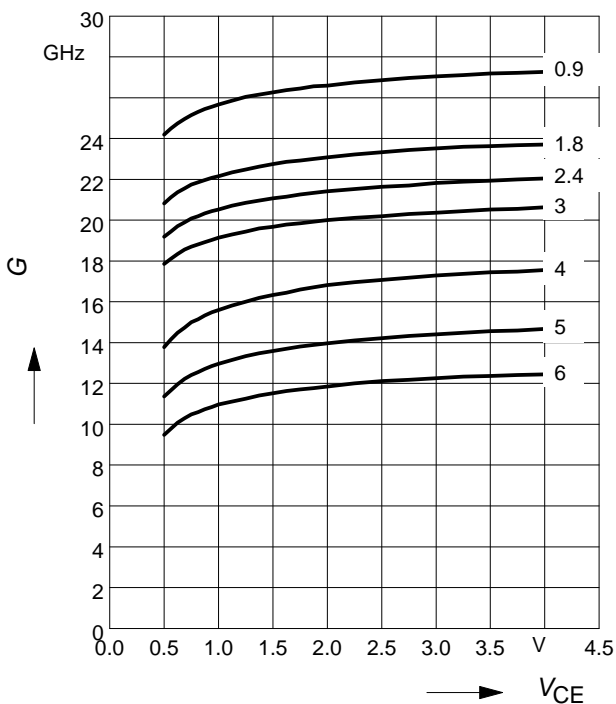

**Collector-base capacitance  $C_{cb} = f(V_{CB})$**   
 $f = 1\text{ MHz}$

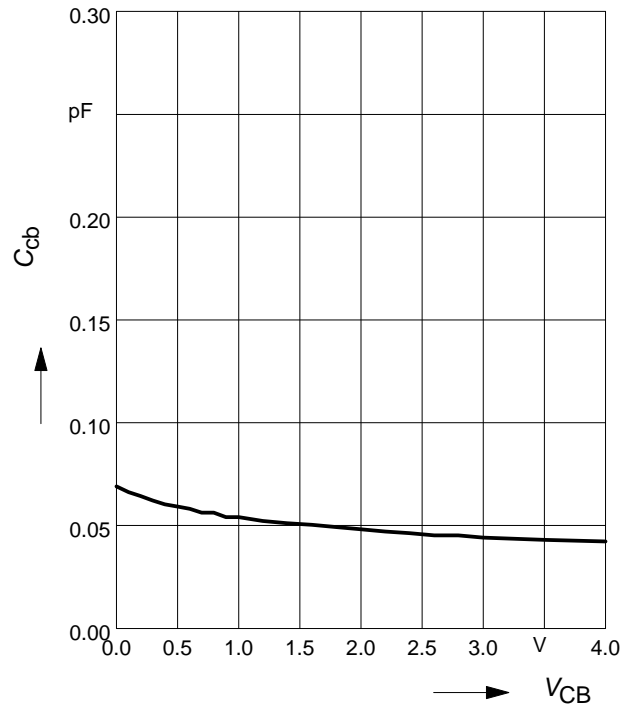

**Noise figure  $F = f(I_C)$**

$V_{CE} = 2\text{ V}, Z_S = Z_{Sopt}$

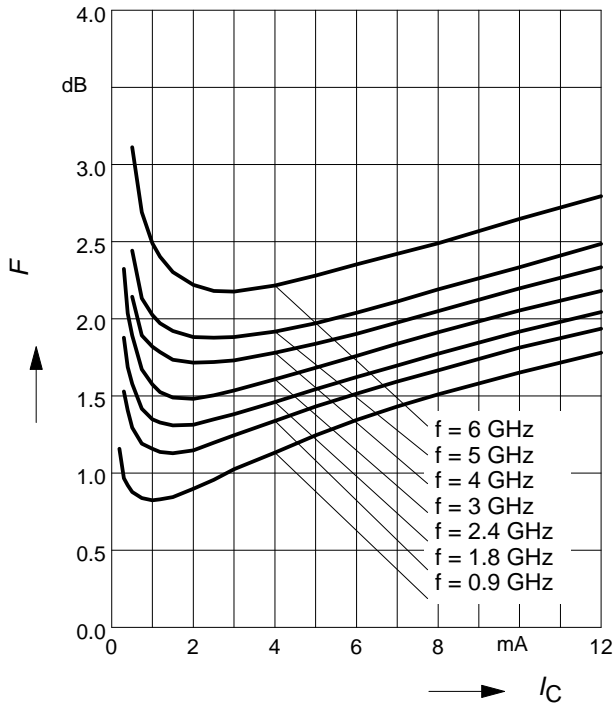

**Noise figure  $F = f(I_C)$**

$V_{CE} = 2\text{ V}, f = 1.8\text{ GHz}$

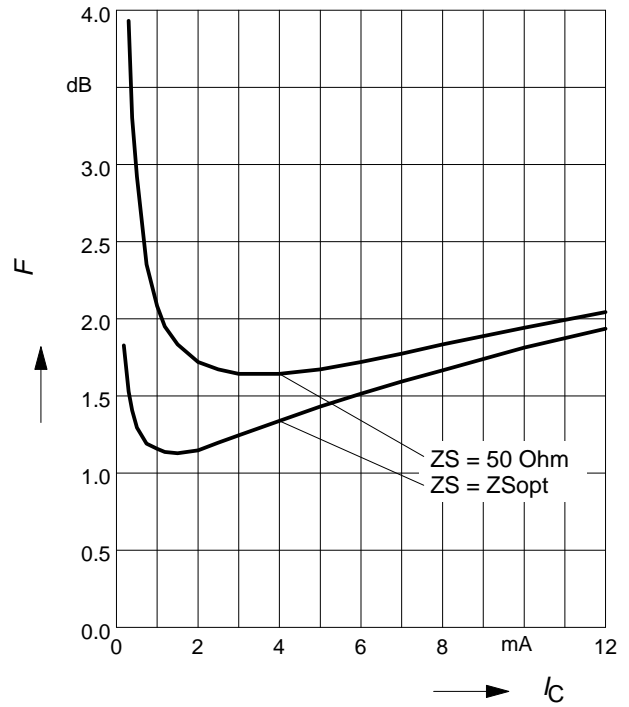

**Noise figure  $F = f(f)$**

$V_{CE} = 2\text{ V}, Z_S = Z_{Sopt}$

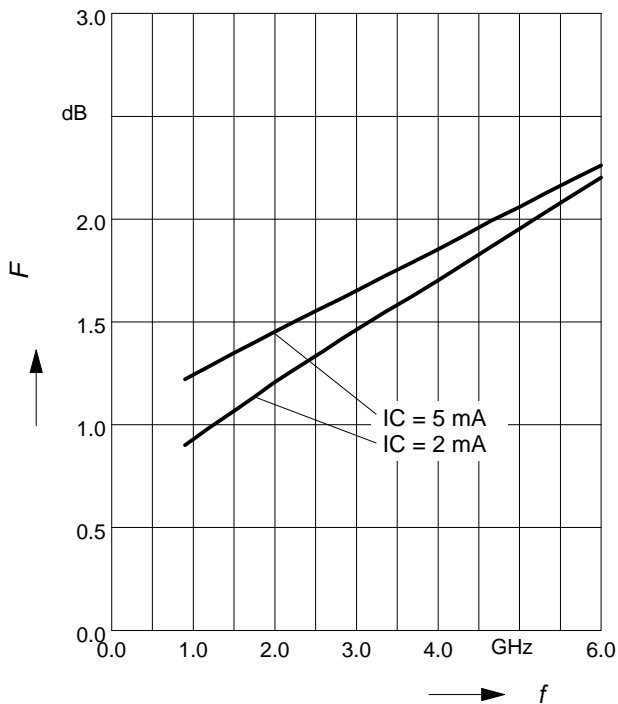

**Source impedance for min.**

Noise Figure versus Frequency

$V_{CE} = 2\text{ V}, I_C = 2\text{ mA} / 5\text{ mA}$

