

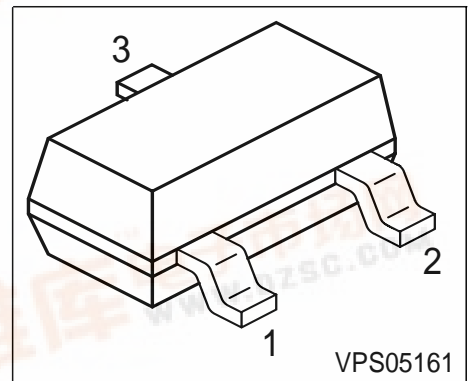

**BFR35AP**

**NPN Silicon RF Transistor**

- For low distortion broadband amplifiers and oscillators up to 2GHz at collector currents from 0.5mA to 20 mA



**ESD:** Electrostatic discharge sensitive device, observe handling precaution!

Type	Marking	Pin Configuration			Package
BFR35AP	GEs	1 = B	2 = E	3 = C	SOT23

**Maximum Ratings**

Parameter	Symbol	Value	Unit
Collector-emitter voltage	$V_{CEO}$	15	V
Collector-emitter voltage	$V_{CES}$	20	
Collector-base voltage	$V_{CBO}$	20	
Emitter-base voltage	$V_{EBO}$	2.5	
Collector current	$I_C$	30	mA
Base current	$I_B$	4	
Total power dissipation <sup>1)</sup> $T_S \leq 48^\circ\text{C}$	$P_{tot}$	280	mW
Junction temperature	$T_j$	150	$^\circ\text{C}$
Ambient temperature	$T_A$	-65 ... 150	
Storage temperature	$T_{stg}$	-65 ... 150	

**Thermal Resistance**

Parameter	Symbol	Value	Unit
Junction - soldering point <sup>2)</sup>	$R_{thJS}$	$\leq 365$	K/W

<sup>1)</sup>  $T_S$  is measured on the collector lead at the soldering point to the pcb

<sup>2)</sup> For calculation of  $R_{thJA}$  please refer to Application Note Thermal Resistance

**Electrical Characteristics**

Parameter	Symbol	Values			Unit
		min.	typ.	max.	
<b>Characteristics</b>					
Collector-emitter breakdown voltage $I_C = 1 \text{ mA}, I_B = 0$	$V_{(BR)CEO}$	15	-	-	V
Collector-emitter cutoff current $V_{CE} = 20 \text{ V}, V_{BE} = 0$	$I_{CES}$	-	-	10	$\mu\text{A}$
Collector -base cutoff current $V_{CB} = 10 \text{ V}, I_E = 0$	$I_{CBO}$	-	-	100	nA
Emitter-base cutoff current $V_{EB} = 2.5 \text{ V}, I_C = 0$	$I_{EBO}$	-	-	100	$\mu\text{A}$
DC current gain- $I_C = 15 \text{ mA}, V_{CE} = 8 \text{ V}$	$h_{FE}$	40	100	200	-

**Electrical Characteristics**

Parameter	Symbol	Values			Unit
		min.	typ.	max.	
<b>AC Characteristics</b>					
Transition frequency $I_C = 15 \text{ mA}$ , $V_{CE} = 8 \text{ V}$ , $f = 500 \text{ MHz}$	$f_T$	3.5	5	-	GHz
Collector-base capacitance $V_{CB} = 10 \text{ V}$ , $f = 1 \text{ MHz}$	$C_{cb}$	-	0.38	0.6	pF
Collector emitter capacitance $V_{CE} = 10 \text{ V}$ , $f = 1 \text{ MHz}$	$C_{ce}$	-	0.2	-	
Emitter-base capacitance $V_{EB} = 0.5 \text{ V}$ , $f = 1 \text{ MHz}$	$C_{eb}$	-	0.7	-	
Noise figure $I_C = 2 \text{ mA}$ , $V_{CE} = 6 \text{ V}$ , $Z_S = Z_{Sopt}$ , $f = 900 \text{ MHz}$ $f = 1.8 \text{ GHz}$	$F$	-	1.8	-	dB
		-	2.9	-	
Power gain, maximum available <sup>1)</sup> $I_C = 15 \text{ mA}$ , $V_{CE} = 8 \text{ V}$ , $Z_S = Z_{Sopt}$ , $Z_L = Z_{Lopt}$ , $f = 900 \text{ MHz}$ $f = 1.8 \text{ GHz}$	$G_{ma}$	-	15	-	
		-	9.5	-	
Transducer gain $I_C = 15 \text{ mA}$ , $V_{CE} = 8 \text{ V}$ , $Z_S = Z_L = 50\Omega$ , $f = 900 \text{ MHz}$ $f = 1.8 \text{ GHz}$	$ S_{21e} ^2$	-	12.5	-	
		-	7	-	

<sup>1</sup> $G_{ma} = |S_{21}/S_{12}| (k - (k^2 - 1)^{1/2})$