

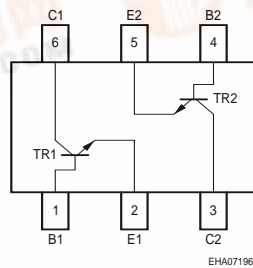

BFS17S

NPN Silicon RF Transistor

- For broadband amplifiers up to 1 GHz at collector currents from 1 mA to 20 mA

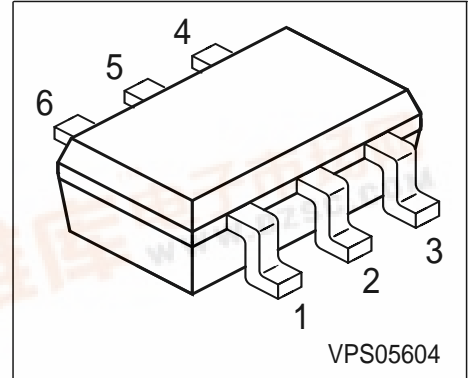

Type	Marking	Pin Configuration					Package	
BFS17S	MCs	1=B1	2=E1	3=C2	4=B2	5=E2	6=C1	SOT363

Maximum Ratings

Parameter	Symbol	Value	Unit
Collector-emitter voltage	V_{CEO}	15	V
Collector-base voltage	V_{CBO}	25	
Emitter-base voltage	V_{EBO}	2.5	
Collector current	I_C	25	mA
Peak collector current, $f = 10$ MHz	I_{CM}	50	
Total power dissipation $T_S \leq 93$ °C 1)	P_{tot}	280	mW
Junction temperature	T_j	150	°C
Ambient temperature	T_A	-65 ... 150	
Storage temperature	T_{stg}	-65 ... 150	

Thermal Resistance

Junction - soldering point 2)	R_{thJS}	≤ 240	K/W
-------------------------------	------------	------------	-----

1 T_S is measured on the collector lead at the soldering point to the pcb

2 For calculation of R_{thJA} please refer to Application Note Thermal Resistance



Electrical Characteristics at $T_A = 25^\circ\text{C}$, unless otherwise specified.

Parameter	Symbol	Values			Unit
		min.	typ.	max.	
DC characteristics					
Collector-emitter breakdown voltage $I_C = 1 \text{ mA}, I_B = 0$	$V_{(BR)CEO}$	15	-	-	V
Collector-base cutoff current $V_{CB} = 10 \text{ V}, I_E = 0$ $V_{CB} = 25 \text{ V}, I_E = 0$	I_{CBO}	-	-	0.05 10	μA
Emitter-base cutoff current $V_{EB} = 2.5 \text{ V}, I_C = 0$	I_{EBO}	-	-	100	
DC current gain $I_C = 2 \text{ mA}, V_{CE} = 1 \text{ V}$ $I_C = 25 \text{ mA}, V_{CE} = 1 \text{ V}$	h_{FE}	20 20	- 70	150 -	-
Collector-emitter saturation voltage $I_C = 10 \text{ mA}, I_B = 1 \text{ mA}$	V_{CEsat}	-	0.1	0.4	V

Electrical Characteristics at $T_A = 25^\circ\text{C}$, unless otherwise specified.

Parameter	Symbol	Values			Unit
		min.	typ.	max.	
AC characteristics					
Transition frequency $I_C = 2 \text{ mA}$, $V_{CE} = 5 \text{ V}$, $f = 200 \text{ MHz}$ $I_C = 25 \text{ mA}$, $V_{CE} = 5 \text{ V}$, $f = 200 \text{ MHz}$	f_T	1 1.3	1.4 2.5	- -	GHz
Collector-base capacitance $V_{CB} = 5 \text{ V}$, $f = 1 \text{ MHz}$	C_{cb}	-	0.55	0.8	pF
Collector-emitter capacitance $V_{CE} = 5 \text{ V}$, $f = 1 \text{ MHz}$	C_{ce}	-	0.13	-	
Input capacitance $V_{EB} = 0.5 \text{ V}$, $I_C = 0$, $f = 1 \text{ MHz}$	C_{ibo}	-	1.45	-	
Output capacitance $V_{CE} = 5 \text{ V}$, $V_{BE} = 0$, $f = 1 \text{ MHz}$	C_{obs}	-	-	1.5	
Noise figure $I_C = 2 \text{ mA}$, $V_{CE} = 5 \text{ V}$, $f = 800 \text{ MHz}$, $Z_S = 0 \Omega$	F	-	3.5	5	dB
Transducer gain $I_C = 20 \text{ mA}$, $V_{CE} = 5 \text{ V}$, $Z_S = Z_L = 50 \Omega$, $f = 500 \text{ MHz}$	$ S_{21e} ^2$	-	12,7	-	
Linear output voltage $I_C = 14 \text{ mA}$, $V_{CE} = 5 \text{ V}$, $d_{im} = 60 \text{ dB}$, $f_1 = 806 \text{ MHz}$, $f_2 = 810 \text{ MHz}$, $Z_S = Z_L = 50 \Omega$	$V_{01} = V_{02}$	-	100	-	mV
Third order intercept point $I_C = 200 \text{ mA}$, $V_{CE} = 8 \text{ V}$, $Z_S = Z_{Sopt}$, $Z_L = Z_{Lopt}$, $f = 900 \text{ MHz}$	IP_3	-	23	-	dBm

Total power dissipation $P_{tot} = f(T_S)$

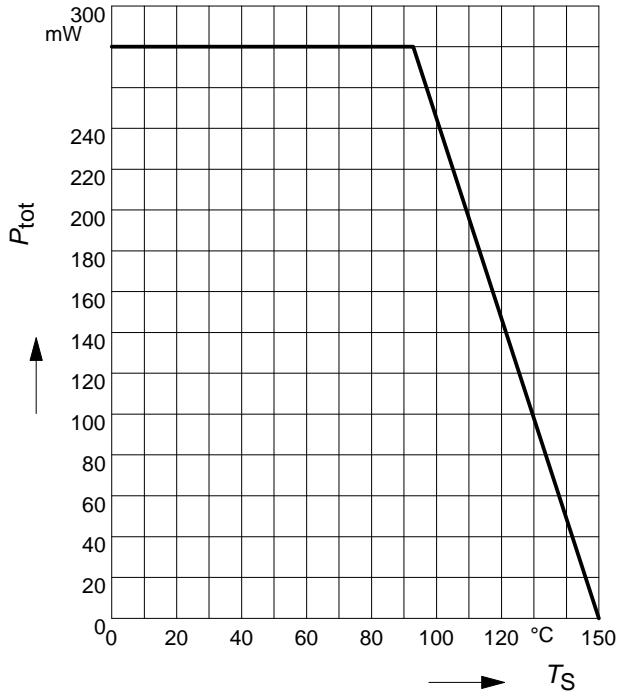

Permissible Pulse Load $R_{thJS} = f(t_p)$

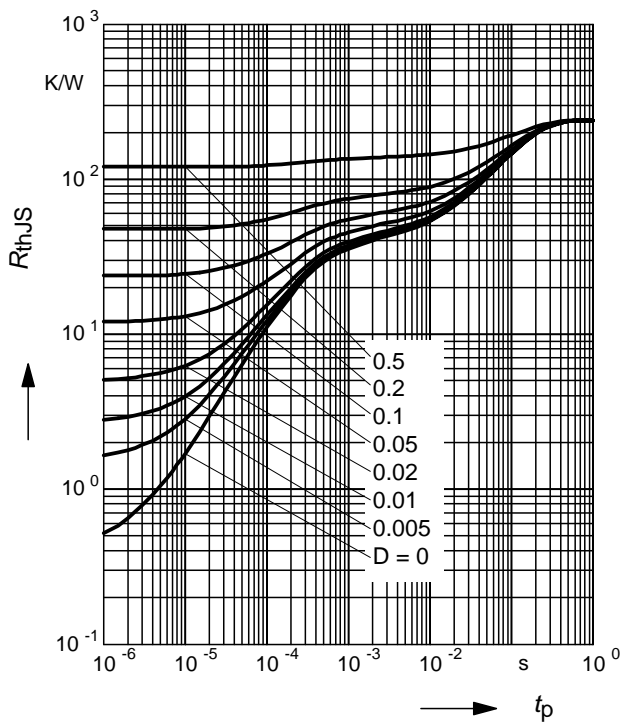

Permissible Pulse Load

$P_{totmax}/P_{totDC} = f(t_p)$

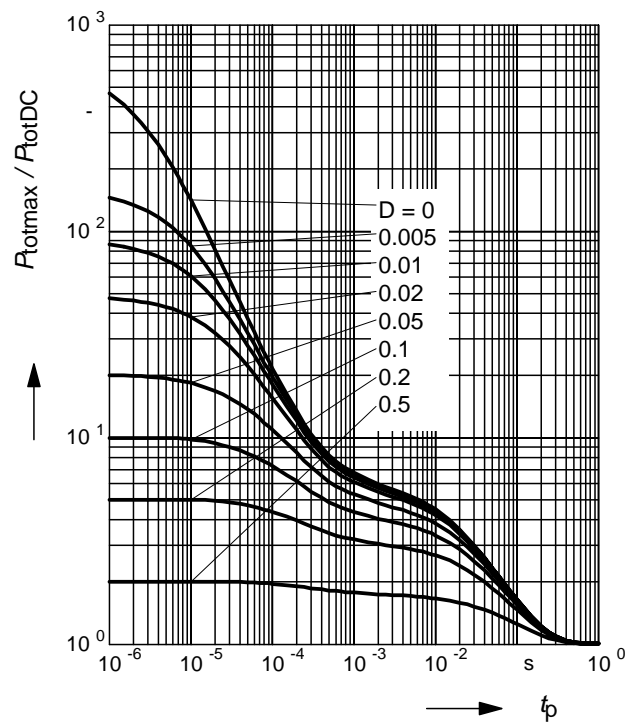

Collector-base capacitance $C_{cb} = f(V_{CB})$
 $f = 1\text{MHz}$

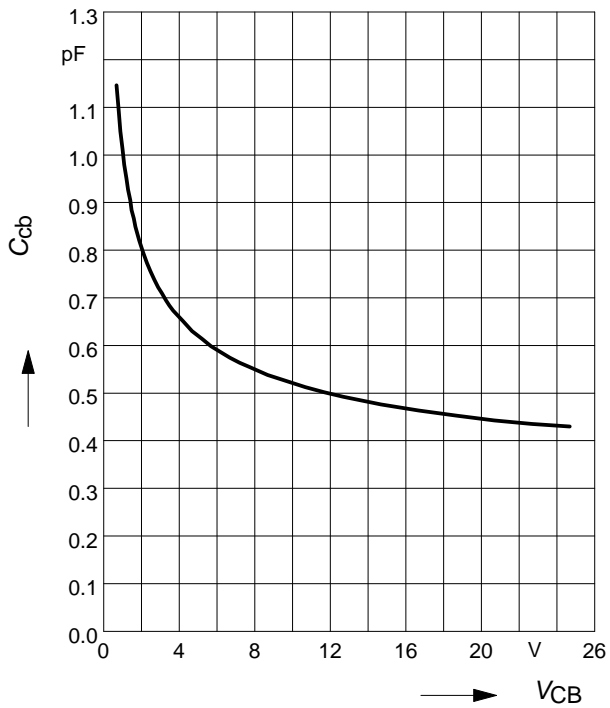

Transition frequency $f_T = f(I_C)$

$V_{CE} = \text{Parameter}$

