

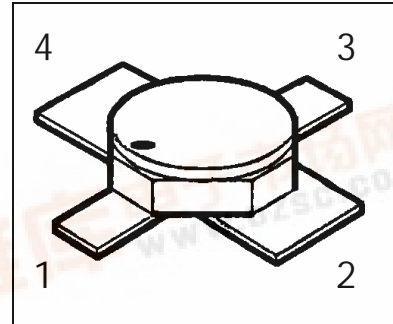

HiRel NPN Silicon RF Transistor

- **HiRel Discrete and Microwave Semiconductor**
- For High Gain Low Noise Amplifiers
- For Oscillators up to 10 GHz
- Noise Figure F = 1.1 dB at 1.8 GHz
Outstanding Gms = 21dB at 1.8 GHz
- Hermetically sealed microwave package
- Transition Frequency $f_T = 22$ GHz
- **SIEGET 25-Line**
Infineon Technologies Grounded Emitter Transistor-
25 GHz f_T -Line



ESA Space Qualified

ESA/SCC Detail Spec. No.: 5611/008
Type Variant No. 02

ESD: Electrostatic discharge sensitive device,
observe handling precautions!

Type	Marking	Ordering Code	Pin Configuration				Package
			1	2	3	4	
BFY420 (ql)	-	see below	C	E	B	E	Micro-X

(ql) Quality Level:	P: Professional Quality,	Ordering Code:	Q62702F1662
	H: High Rel Quality,	Ordering Code:	on request
	S: Space Quality,	Ordering Code:	on request
	ES: ESA Space Quality,	Ordering Code:	Q62702F1709

(see order instructions for ordering example)



Maximum Ratings

Parameter	Symbol	Values	Unit
Collector-emitter voltage	V_{CEO}	4.5	V
Collector-base voltage	V_{CBO}	15	V
Emitter-base voltage	V_{EBO}	1.5	V
Collector current	I_C	35	mA
Base current	I_B	3.0	mA
Total power dissipation, $T_S \leq 129^\circ\text{C}$ ^{1), 2)}	P_{tot}	160	mW
Junction temperature	T_j	175	$^\circ\text{C}$
Operating temperature range	T_{op}	-65...+175	$^\circ\text{C}$
Storage temperature range	T_{stg}	-65...+175	$^\circ\text{C}$

Thermal Resistance

Junction-soldering point ²⁾	R_{thJS}	< 285	K/W
--	------------	-------	-----

Notes.:

- 1) At $T_S = +129^\circ\text{C}$. For $T_S > +129^\circ\text{C}$ derating is required.
- 2) T_S is measured on the collector lead at the soldering point to the pcb.

Electrical Characteristics

 at $T_A=25^\circ\text{C}$; unless otherwise specified

Parameter	Symbol	Values			Unit
		min.	typ.	max.	
Collector-base cutoff current $V_{CB} = 5\text{ V}, I_E = 0$	I_{CBO}	-	-	30	nA
Collector-emitter cutoff current ^{1.)} $V_{CE} = 4.5\text{ V}, I_B = 1.0\mu\text{A}$	I_{CEX}	-	-	200 (t.b.d.)	μA
Emitter-base cutoff current $V_{EB} = 1.5\text{ V}, I_C = 0$	I_{EBO}	-	-	20	μA
DC current gain $I_C = 5\text{ mA}, V_{CE} = 1\text{ V}$	h_{FE}	50	90	150	-

Notes:

- 1.) This Test assures $V(BR)_{CE0} > 4.5\text{V}$

Electrical Characteristics (continued)

Parameter	Symbol	Values			Unit
		min.	typ.	max.	
AC Characteristics					
Transition frequency $I_C = 30\text{mA}$, $V_{CE} = 3\text{ V}$, $f = 2.0\text{ GHz}$	f_T	20	22	-	GHz
Collector-base capacitance $V_{CB} = 2\text{ V}$, $V_{BE} = v_{be} = 0$, $f = 1\text{ MHz}$	C_{CB}	-	0.14	0.9	pF
Collector-emitter capacitance $V_{CE} = 2\text{ V}$, $V_{BE} = v_{be} = 0$, $f = 1\text{ MHz}$	C_{CE}	-	0.46	0.85	pF
Emitter-base capacitance $V_{EB} = 0.5\text{V}$, $V_{CB} = v_{cb} = 0$, $f = 1\text{ MHz}$	C_{EB}	-	0.67	3.0	pF
Noise Figure $I_C = 5\text{ mA}$, $V_{CE} = 2\text{ V}$, $f = 1.8\text{ GHz}$, $Z_S = Z_{\text{sopt}}$	F	-	1.1	1.7	dB
Insertion power gain $I_C = 20\text{ mA}$, $V_{CE} = 2\text{ V}$, $f = 1.8\text{ GHz}$ $Z_S = Z_L = 50\ \Omega$	$ S_{21e} ^2$	14	18	-	dB
Power gain $I_C = 20\text{ mA}$, $V_{CE} = 2\text{ V}$, $f = 1.8\text{ GHz}$ $Z_S = Z_{\text{Sopt}}$, $Z_L = Z_{\text{Lopt}}$	G_{ms} ¹⁾	-	21	-	dB
1dB Compression point $I_C = 20\text{ mA}$, $V_{CE} = 2\text{ V}$, $f = 1.8\text{ GHz}$ $Z_S = Z_{\text{Sopt}}$, $Z_L = Z_{\text{Lopt}}$	$P_{-1\text{dB}}$	-	12	-	dBm

Notes.:

$$1) \quad G_{ms} = \left| \frac{S_{21}}{S_{12}} \right|$$

Order Instructions:

Full type variant including quality level must be specified by the orderer. For *HiRel* Discrete and Microwave Semiconductors the ordering code specifies device family and quality level.

Ordering Form:

Ordering Code: Q.....
BFY420 (ql)
(ql): Quality Level

Ordering Example:

Ordering Code: Q62702F1709
BFY420 ES
For BFY420 in ESA Space Quality Level

Further Informations:

See our WWW-Pages:

- Discrete and RF-Semiconductors (Small Signal Semiconductors)
www.infineon.com/products/discrete/hirel.htm

- *HiRel* Discrete and Microwave Semiconductors
www.infineon.com/products/discrete/hirel.htm

Please contact also our marketing division :

Tel.: ++89 234 24480
Fax.: ++89 234 28438
e-mail: martin.wimmers@infineon.com
Address: Infineon Technologies Semiconductors,
High Frequency Products Marketing,
P.O.Box 801709,
D-81617 Munich

Micro-X Package

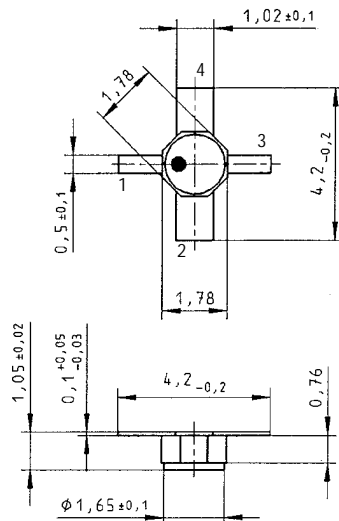

Published by Infineon Technologies Semiconductors, High Frequency Products Marketing, P.O.Box 801709, D-81617 Munich.

Infineon Technologies AG 1998. All Rights Reserved.

As far as patents or other rights of third parties are concerned, liability is only assumed for components per se, not for applications, processes and circuits implemented within components or assemblies.

The information describes the type of component and shall not be considered as assured characteristics.

Terms of delivery and rights to change design reserved.

For questions on technology, delivery and prices please contact the Offices of Semiconductor Group in Germany or the Infineon Technologies Companies and Representatives worldwide (see address list).

Due to technical requirements components may contain dangerous substances. For information on the type in question please contact your nearest Infineon Technologies Office, Semiconductor Group.

Infineon Technologies Semiconductors is a certified CECC and QS9000 manufacturer (this includes ISO 9000).