

VHF amplifier module

BGY145B

DESCRIPTION

The BGY145B is a RF amplifier module, designed for use in transmitters of mobile communications equipment powered by vehicles with 12.5 V battery supplies.

The module is a two-stage transistor amplifier and consists of two RF npn transistors mounted on a ceramic substrate, together with surface mounted components that make up the matching and bias circuits.

The module will provide 28 W RF power into a 50 Ω load, when operated at nominal conditions within the frequency range of 146 to 174 MHz.

PINNING - SOT183A

PIN	DESCRIPTION
1	output
2	V_{S2}
3	V_{S1}
4	input
flange	ground

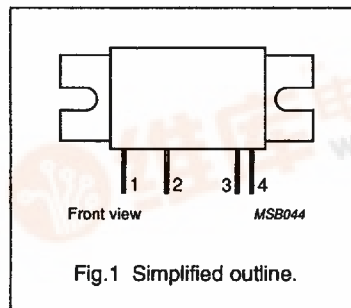

QUICK REFERENCE DATA

Mode of operation: continuous wave.

SYMBOL	PARAMETER	CONDITIONS	MIN.	TYP.	MAX.	UNIT
f	frequency range		146	–	174	MHz
P_D	RF output power	$P_D = 300 \text{ mW}$	28	–	–	W
G_p	RF power gain	$P_L = 28 \text{ W}$	19.7	–	–	dB
η	efficiency	$P_L = 28 \text{ W}$	40	–	–	%
V_{S1}, V_{S2}	DC supply voltage		–	12.5	–	V
Z_i	input impedance		–	50	–	Ω
Z_L	output load impedance		–	50	–	Ω

VHF amplifier module

BGY145B

LIMITING VALUES

In accordance with the Absolute Maximum System (IEC 134).

SYMBOL	PARAMETER	MIN.	MAX.	UNIT
V_{S1}, V_{S2}	DC supply voltage	-	15.5	V
$\pm V_i$	RF input terminal voltage	-	25	V
$\pm V_o$	RF output terminal voltage	-	25	V
P_D	RF input power	-	450	mW
P_L	RF output power (see Fig.2)	-	40	W
T_{stg}	storage temperature range	-30	100	°C
T_h	heatsink operating temperature	-	90	°C

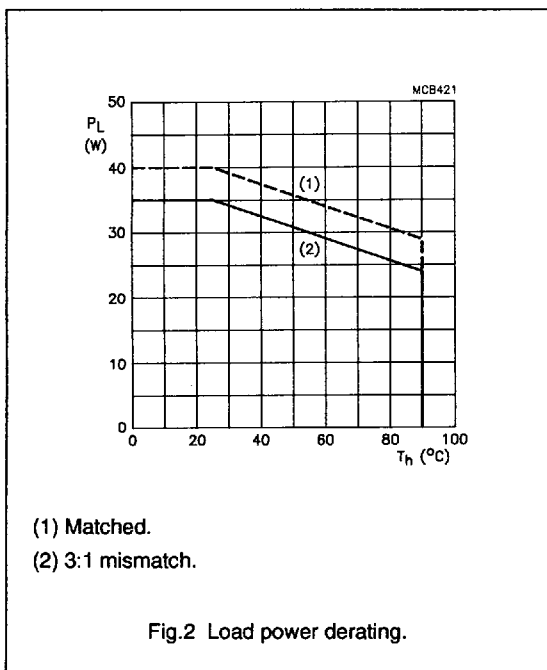

CHARACTERISTICS

$T_h = 25\text{ °C}$; $V_{S1} = V_{S2} = 12.5\text{ V}$; $R_S = R_L = 50\text{ }\Omega$; frequency range = 146 to 174 MHz.

SYMBOL	PARAMETER	CONDITIONS	MIN.	TYP.	MAX.	UNIT
I_{Q1}	quiescent current	$P_D = 0$	-	10	25	mA
I_{Q2}	quiescent current	$P_D = 0$	-	-	35	mA
P_L	RF output power	$P_D = 300\text{ mW}$	28	-	-	W
G_p	RF power gain	$P_L = 28\text{ W}$	19.7	-	-	dB
η	efficiency	$P_L = 28\text{ W}$	40	-	-	%
H_{R2}, H_{R3}	2nd & 3rd harmonic outputs	$P_L = 28\text{ W}$	-	-	-30	dBc
	input VSWR with respect to 50 Ω	$P_L = 28\text{ W}$	-	-	2:1	

VHF amplifier module

BGY145B

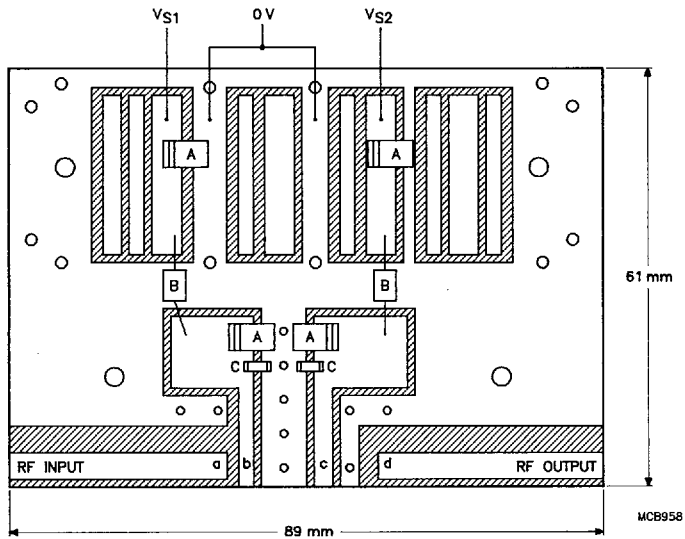

Epoxy fibre-glass board, 1/16 inch thick, $\epsilon_r = 4.5$.

A: $10 \mu\text{F}$, 16 V, tantalum chip capacitor.

B: 2 turns FX1115 Ferroxcube bead.

C: $0.1 \mu\text{F}$, 60 V, ceramic multilayer chip capacitor.

Track widths 'a' and 'd' (50Ω) = 4 mm.

Track width 'b' = 2.5 mm.

Track width 'c' = 3 mm.

Circles indicate the positions of through rivets.

Fig.3 Test jig.

VHF amplifier module

BGY145B

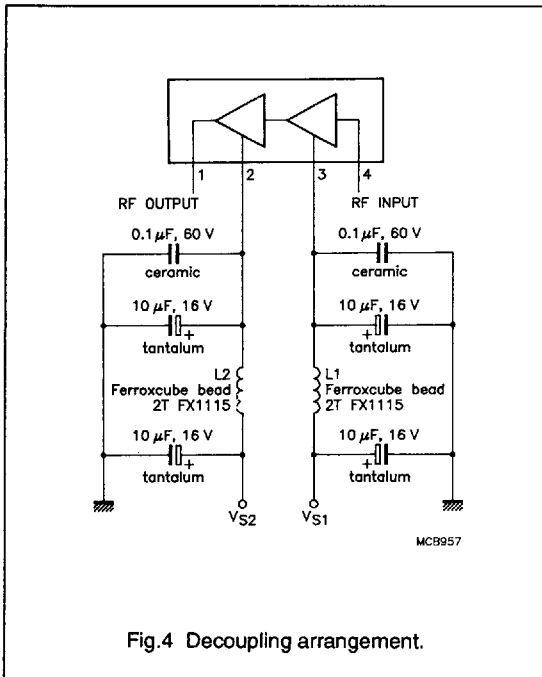
**STABILITY**

The module is stable when operated into a load of 3:1 at all phases, providing the operating conditions are as follows:

$$P_D \text{ 30 to 450 mW; } P_L \geq 3 \text{ to } \leq 40 \text{ W;}$$

$$V_{S1} = 3 \text{ to } 15.5 \text{ V;}$$

$$V_{S2} = 10.5 \text{ to } 15.5 \text{ V and } V_{S1} < V_{S2}.$$

RUGGEDNESS

The output power of the module into a 50 Ω load will be unchanged after one minute of operation into a load mismatch of 20:1 (any phase), providing maximum ratings are not exceeded.

$$V_{S1}, V_{S2} \leq 15.5 \text{ V; } T_h \leq 90 \text{ }^\circ\text{C;}$$

$$P_L \leq 40 \text{ W; } P_D < 450 \text{ mW.}$$

RF POWER CONTROL

The module is designed to be operated at constant output power

However, the module may be operated over a range of output power levels by varying the input drive power level, P_{IN} . For stable operation, care must be taken to maintain conditions within the specified range:

$$P_D \text{ 30 to 450 mW; } V_{S1} = 3 \text{ V to } V_{S2};$$

$$P_L = 3 \text{ to } 28 \text{ W.}$$

CAUTIONS

The main earth return path for this module is via the flange. Therefore, it is important that the heatsink is well earthed and that the return paths are kept as short as possible. Failure to do this may result in loss of output power or oscillation, which will have a detrimental effect upon the life of the module.

The RF output connection should be made to correctly designed 50 Ω terminals. Failure to do so will result

in a mismatch being presented to the module, with a resultant reduction in module life.

The leads of the devices may be soldered directly into a circuit using a soldering iron with a maximum temperature of 245 $^\circ\text{C}$, for not more than 10 seconds at a distance of at least 1 mm from the plastic.

Under no circumstances must the maximum specified operating or storage temperatures be exceeded, even for short periods.

VHF amplifier module

BGY145B

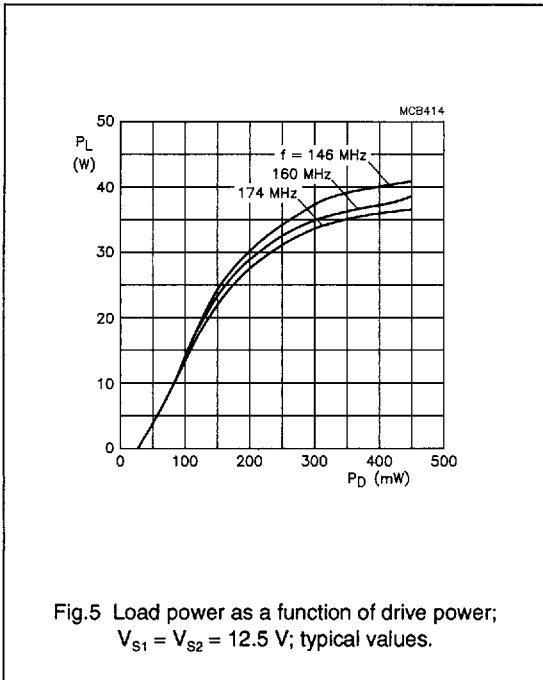

Fig.5 Load power as a function of drive power; $V_{S1} = V_{S2} = 12.5$ V; typical values.

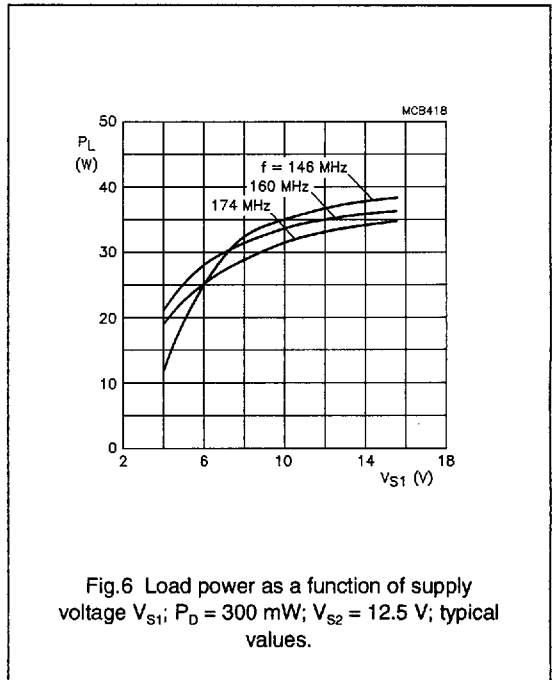

Fig.6 Load power as a function of supply voltage V_{S1} ; $P_D = 300$ mW; $V_{S2} = 12.5$ V; typical values.

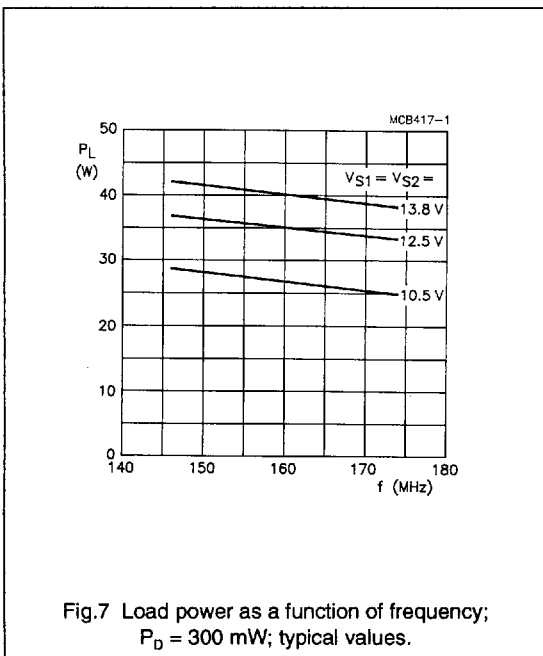

Fig.7 Load power as a function of frequency; $P_D = 300$ mW; typical values.

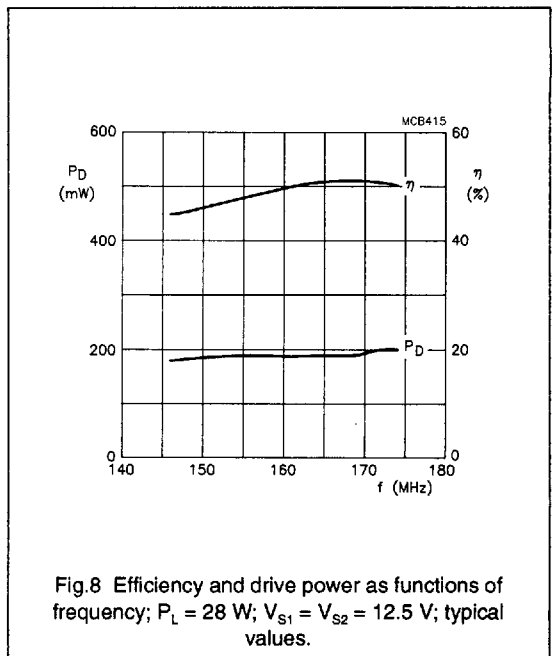

Fig.8 Efficiency and drive power as functions of frequency; $P_L = 28$ W; $V_{S1} = V_{S2} = 12.5$ V; typical values.

VHF amplifier module

BGY145B

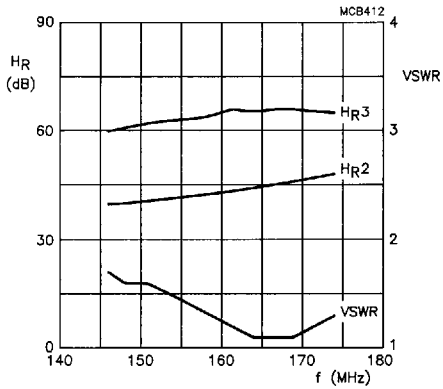
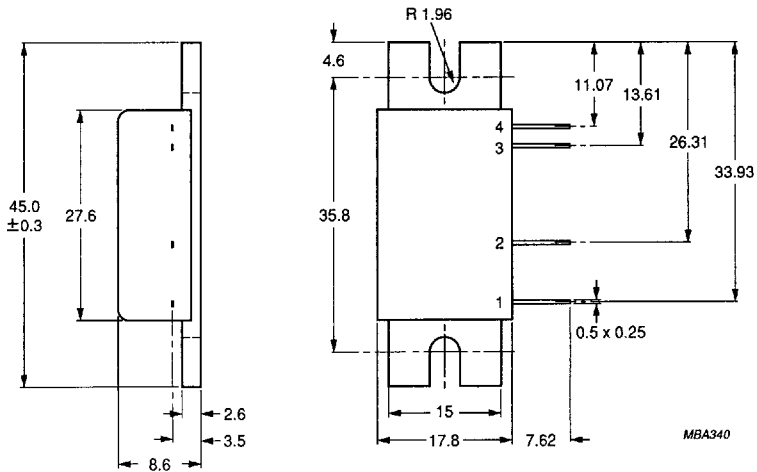

Fig.9 Second and third harmonic rejection as a function of frequency; $P_L = 28\text{ W}$; $V_{S1} = V_{S2} = 12.5\text{ V}$; typical values.

VHF amplifier module

BGY145B

PACKAGE OUTLINE



Dimensions in mm.

Fig.10 SOT183A.