

BH3874AKS2

Audio ICs

# Sound processor IC

## BH3874AKS2

The BH3874AKS2 is a sound control IC for mini-component stereo. 4-ch input selector, vocal fade, volume, surround, 5-band graphic equalizer, dynamic bass, and 5-band spectrum analyzer are integrated into a single chip. Soft switch can reduce the switching noise occurred when volume, vocal fade, surround, and dynamic bass are switched.

### ●Applications

Mini component stereo, Micro component stereo, CD radio cassette players, and TV.

### ●Features

- 1) A single chip IC integrates all functions of volume, tone control, and spectrum analyzer.
- 2) Soft switching can reduce the noise occurred when volume, mode selector, surround, dynamic bass, and gain of graphic equalizer are switched.
- 3) 4-ch input selector, mode selector, volume, surround, graphic equalizer, dynamic bass, and spectrum analyzer.
- 4) Built-in matrix surround, pseudo stereo circuit, and band pass filter for spectrum analyzer.
- 5) Low distortion and low noise due to the BiCMOS process adopting resistance ladder volume.
- 6) Filters of dynamic bass and biamp can be set freely by the combination of LPF and HPF.

### ●Absolute maximum ratings (Ta=25°C)

| Parameter                   | Symbol | Limits      | Unit |
|-----------------------------|--------|-------------|------|
| Power supply voltage        | Vcc    | 10.0        | V    |
| Power dissipation           | Pd     | 1200*       | mW   |
| Operating temperature range | Topr   | -12 to +85  | °C   |
| Storage temperature range   | Tstg   | -55 to +125 | °C   |

\* Reduced by 12mW for each increase in Ta of 1°C over 25°C.  
A standard board, 70×70×1.6mm, shall be mounted.

### ●Recommended operating conditions (Ta=25°C)

| Parameter            | Symbol | Min. | Typ. | Max. | Unit |
|----------------------|--------|------|------|------|------|
| Power supply voltage | Vcc    | 8.0  | -    | 9.5  | V    |

Audio ICs

●Block diagram

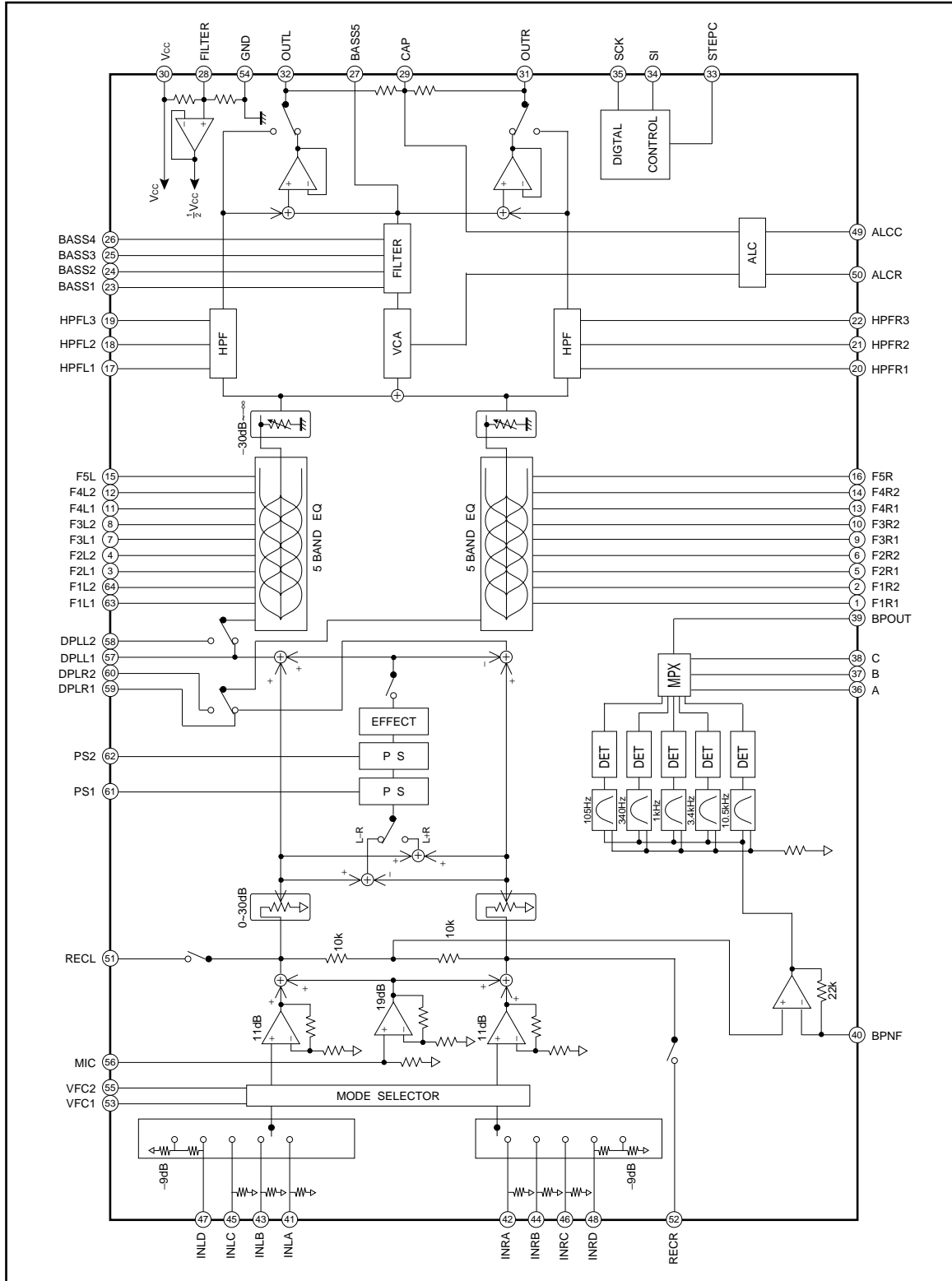

## Audio ICs

## ●Pin descriptions

| Pin No. | Pin name        | Function                         | Pin No. | Pin name | Function  |
|---------|-----------------|----------------------------------|---------|----------|---|
| 1       | F1R1            | Rch GREQ f1 filter setting pin   | 33      | STEPC    | Time constant attachment for switching shock protection |
| 2       | F1R2            | Rch GREQ f1 filter setting pin   | 34      | SI       | Serial data latch receiving pin                         |
| 3       | F2L1            | Lch GREQ f2 filter setting pin   | 35      | SCK      | Serial clock receiving pin                              |
| 4       | F2L2            | Lch GREQ f2 filter setting pin   | 36      | A        | Parallel data receiving pin                             |
| 5       | F2R1            | Rch GREQ f2 filter setting pin   | 37      | B        | Parallel data receiving pin                             |
| 6       | F2R2            | Rch GREQ f2 filter setting pin   | 38      | C        | Parallel data receiving pin                             |
| 7       | F3L1            | Lch GREQ f3 filter setting pin   | 39      | BPOUT    | Output pin for spectrum analyzer                        |
| 8       | F3L2            | Lch GREQ f3 filter setting pin   | 40      | BPNF     | Spectrum analyzer level setting pin                     |
| 9       | F3R1            | Rch GREQ f3 filter setting pin   | 41      | INLA     | Lch Sound signal input pin A                            |
| 10      | F3R2            | Rch GREQ f3 filter setting pin   | 42      | INRA     | Rch Sound signal input pin A                            |
| 11      | F4L1            | Lch GREQ f4 filter setting pin   | 43      | INLB     | Lch Sound signal input pin B                            |
| 12      | F4L2            | Lch GREQ f4 filter setting pin   | 44      | INRB     | Rch Sound signal input pin B                            |
| 13      | F4R1            | Rch GREQ f4 filter setting pin   | 45      | INLC     | Lch Sound signal input pin C                            |
| 14      | F4R2            | Rch GREQ f4 filter setting pin   | 46      | INRC     | Rch Sound signal input pin C                            |
| 15      | F5L             | Lch GREQ f5 filter setting pin   | 47      | INLD     | Lch Sound signal input pin D                            |
| 16      | F5R             | Rch GREQ f5 filter setting pin   | 48      | INRD     | Rch Sound signal input pin D                            |
| 17      | HPFL1           | Lch High-pass filter setting pin | 49      | ALCC     | Time constant of ALC setting pin                        |
| 18      | HPFL2           | Lch High-pass filter setting pin | 50      | ALCR     | ALC level setting pin                                   |
| 19      | HPFL3           | Lch High-pass filter setting pin | 51      | RECL     | Lch RECOU output pin                                    |
| 20      | HPFR1           | Rch High-pass filter setting pin | 52      | RECR     | Rch RECOU output pin                                    |
| 21      | HPFR2           | Rch High-pass filter setting pin | 53      | VFC1     | Vocal fade filter setting pin                           |
| 22      | HPFR3           | Rch High-pass filter setting pin | 54      | GND      | Ground pin  |
| 23      | BASS1           | Dynamic bass filter setting pin  | 55      | VFC2     | Vocal fade filter setting pin                           |
| 24      | BASS2           | Dynamic bass filter setting pin  | 56      | MIC      | Input pin for microphone                                |
| 25      | BASS3           | Dynamic bass filter setting pin  | 57      | DPLL1    | Lch Output pin for DPL                                  |
| 26      | BASS4           | Dynamic bass filter setting pin  | 58      | DPLL2    | Lch Input pin for DPL                                   |
| 27      | BASS5           | Biamp output pin                 | 59      | DPLR1    | Rch Output pin for DPL                                  |
| 28      | FILTER          | V <sub>cc</sub> /2 Pin           | 60      | DPLR2    | Rch Input pin for DPL                                   |
| 29      | CAP             | ALC trap frequency setting pin   | 61      | PS1      | Surround setting pin                                    |
| 30      | V <sub>cc</sub> | Power supply pin                 | 62      | PS2      | Surround setting pin                                    |
| 31      | OUTR            | Rch Sound signal output pin      | 63      | F1L1     | Lch GREQ f1 Filter Setting Pin                          |
| 32      | OUTL            | Lch Sound signal output pin      | 64      | F1L2     | Lch GREQ f1 Filter Setting Pin                          |

Audio ICs

●Input / output circuits

| Pin No.                          | Pin name                                     | Pin voltage | Equivalent circuit | Pin description   |
|----------------------------------|--|-------------|--------------------|---|
| 41<br>42<br>43<br>44<br>45<br>46 | INLA<br>INRA<br>INLB<br>INRB<br>INLC<br>INRC | $V_{cc}/2$  |                    | A pin for inputting a sound signal. It is suitable for input of CD, MD, tuner and tape. The input impedance is 50kΩ (upon typical setting). |
| 54                               | GND  | —           | —                  | A ground pin  |
| 53                               | VFC1   | $V_{cc}/2$  |                    | A pin for setting vocal fade frequency characteristic.  |
| 55                               | VFC2   | $V_{cc}/2$  |                    | A pin for setting vocal fade frequency characteristic.  |
| 47<br>48                         | INLD<br>INRD                                 | $V_{cc}/2$  |                    | A pin for inputting a sound signal. The input impedance is 20kΩ (upon typical setting). It is possible to set 0dB or -9dB.                  |
| 51<br>52                         | RECL<br>RECR                                 | $V_{cc}/2$  |                    | A pin for outputting a sound signal for recording.  |

Audio ICs

| Pin No.            | Pin name                     | Pin voltage | Equivalent circuit | Pin description   |
|--------------------|------------------------------|-------------|--------------------|---|
| 63<br>1<br>7<br>9  | F1L1<br>F1R1<br>F3L1<br>F3R1 | $V_{cc}/2$  |                    | A pin for setting graphic equalizer frequency characteristic.                                   |
| 64<br>2<br>8<br>10 | F1L2<br>F1R2<br>F3L2<br>F3R2 | $V_{cc}/2$  |                    | A pin for setting graphic equalizer frequency characteristic.                                   |
| 15<br>16           | F5L<br>F5R                   | $V_{cc}/2$  |                    | A pin for setting graphic equalizer frequency characteristic.                                   |
| 56                 | MIC                          | $V_{cc}/2$  |                    | A pin for inputting a microphone signal.<br>The input impedance is 10kΩ (upon typical setting). |
| 3<br>5<br>11<br>13 | F2L1<br>F2R1<br>F4L1<br>F4R1 | $V_{cc}/2$  |                    | A pin for setting graphic equalizer frequency characteristic.                                   |
| 4<br>6<br>12<br>14 | F2L2<br>F2R2<br>F4L2<br>F4R2 | $V_{cc}/2$  |                    | A pin for setting graphic equalizer frequency characteristic.                                   |

Audio ICs

| Pin No.  | Pin name       | Pin voltage | Equivalent circuit | Pin description                             |
|----------|----------------|-------------|--------------------|---|
| 30       | Vcc            | –           | –                  | Power supply pin.                           |
| 57<br>59 | DPLL1<br>DPLR1 | Vcc/2       |                    | A pin for outputting DPL.                   |
| 58<br>60 | DPLL2<br>DPLR2 | Vcc/2       |                    | A pin for inputting DPL.                    |
| 61<br>62 | PS1<br>PS2     | Vcc/2       |                    | A pin for setting surround phase shifter.   |
| 17<br>20 | HPFL1<br>HPFR1 | Vcc/2       |                    | A pin for setting cut-off frequency of HPF. |
| 18<br>21 | HPFL2<br>HPFR2 | Vcc/2       |                    | A pin for setting cut-off frequency of HPF. |

Audio ICs

| Pin No.  | Pin name       | Pin voltage | Equivalent circuit | Pin description  |
|----------|----------------|-------------|--------------------|--|
| 19<br>22 | HPFL3<br>HPFR3 | $V_{cc}/2$  |                    | A pin for setting cut-off frequency of HPF.                      |
| 50       | ALCR           | -           |                    | A pin for setting threshold to set the ALC.                      |
| 23<br>25 | BASS1<br>BASS3 | $V_{cc}/2$  |                    | A pin for setting Dynamic bass (Biamp) frequency characteristic. |
| 24<br>26 | BASS2<br>BASS4 | $V_{cc}/2$  |                    | A pin for setting Dynamic bass (Biamp) frequency characteristic. |
| 27       | BASS5          | $V_{cc}/2$  |                    | A pin for outputting Biamp.                                      |

Audio ICs

| Pin No.  | Pin name     | Pin voltage | Equivalent circuit | Pin description  |
|----------|--------------|-------------|--------------------|--|
| 28       | FILTER       | $V_{cc}/2$  |                    | A pin for inputting $V_{cc}/2$ from outside of IC.     |
| 54       | GND          | -           | -                  | A ground pin.  |
| 32<br>31 | OUTL<br>OUTR | $V_{cc}/2$  |                    | A pin for outputting a sound signal.                   |
| 29       | CAP          | $V_{cc}/2$  |                    | A pin for specifying trap frequency of ALC.            |
| 49       | ALCC         | 0           |                    | A pin for setting attack time and release time of ALC. |
| 35       | SCK          | -           |                    | A pin for inputting a signal clock.                    |



Audio ICs

| Pin No.        | Pin name    | Pin voltage | Equivalent circuit | Pin description   |
|----------------|-------------|-------------|--------------------|---|
| 34             | SI          | -           |                    | A pin for inputting a serial data.  |
| 33             | STEPC       | -           |                    | Time constant attachment for switching shock protection.                  |
| 36<br>37<br>38 | A<br>B<br>C | -           |                    | A pin for inputting a parallel data.                                      |
| 39             | BPOUT       | -           |                    | A pin for outputting a spectrum analyzer B.P.F..                          |
| 40             | BPNF        | $V_{cc}/2$  |                    | A pin for adjusting gain of non-inverting amplifier in spectrum analyzer. |

## Audio ICs

## ●Electrical characteristics

(Unless otherwise noted, Ta=25°C, Vcc=9V, f=1kHz, Rg=600Ω, RL=10kΩ, VIN=300mVrms, INPUT SELECTOR=Ach, MODE SELECTOR=Through, VOLUME=0dB, SURROUND=0dB, GRAPHIC EQUALIZER=0dB, DYNAMIC BASS=0dB, SPECTRUM ANALYZER=RESET)

| Parameter   | Symbol | Min. | Typ. | Max. | Unit  | Conditions   | Input pin                        | Measurement pin                  | Data setting |     |     |                      |                      |                      |                      |                      | Switch control table |        |             |        |      |      |   |
|---|--------|------|------|------|-------|--|----------------------------------|----------------------------------|--------------|-----|-----|----------------------|----------------------|----------------------|----------------------|----------------------|----------------------|--------|-------------|--------|------|------|---|
|   |        |      |      |      |       |  |                                  |                                  | [1]          | [2] | [3] | [4]                  | [5]                  | [5]                  | [6]                  | [7]                  | [8]                  | SW 1/4 | SW 2/5      | SW 3/6 | SW 7 | SW 8 |   |
| Circuit current   | IQ     | -    | 40   | 60   | mA    | No signal, after power on.                           | -                                | 30                               | -            | -   | -   | -                    | -                    | -                    | -                    | -                    | -                    | -      | 1           | 1      | 1    | 2    | 1 |
| Maximum input voltage   | VIM    | 0.4  | 0.7  | -    | Vrms  | THD=1%   | 41<br>42                         | 32<br>31                         | 00           | 05  | 03  | 04                   | 0C                   | 02                   | 0A                   | 06                   | 81                   | 07     | 1           | 1      | 1    | 2    | 1 |
| Maximum output voltage  | VOM    | 2.0  | 2.5  | -    | Vrms  | THD=1%   | 41<br>42                         | 32<br>31                         | 00           | 05  | 03  | 04                   | 0C                   | 02                   | 0A                   | 06                   | 81                   | 07     | 1           | 1      | 1    | 2    | 1 |
| Voltage gain  | GV     | 9    | 11   | 13   | dB    |  | 41<br>42                         | 32<br>31                         | 00           | 05  | 03  | 04                   | 0C                   | 02                   | 0A                   | 06                   | 81                   | 07     | 1           | 1      | 1    | 2    | 1 |
| Total harmonic distortion rate                                | THD    | -    | 0.01 | 0.05 | %     | VIN=150mVrms, 400Hz-30kHz BPF                        | 41<br>42                         | 32<br>31                         | 00           | 05  | 03  | 04                   | 0C                   | 02                   | 0A                   | 06                   | 81                   | 07     | 1           | 1      | 1    | 2    | 1 |
| Output noise voltage *  | VNO    | -    | 35   | 50   | μVrms | Biamp=0dB, DIN AUDIO                                 | 41<br>42                         | 32<br>31                         | 00           | 15  | 03  | 04                   | 0C                   | 02                   | 0A                   | 06                   | 89                   | 07     | 1           | 2      | -    | 2    | 1 |
| Residual output noise voltage *                               | VMNO   | -    | 5    | 20   | μVrms | Rg=0Ω, Volume=-∞, Biamp=0dB, DIN AUDIO               | 41<br>42                         | 32<br>31                         | 00           | 15  | 03  | 04                   | 0C                   | 02                   | 0A                   | 06                   | 89                   | 07     | 1           | 2      | -    | 2    | 1 |
| Cross talk *  | CT     | 70   | 80   | -    | dB    | Biamp=0dB, Rg=0Ω, DIN AUDIO                          | 41<br>42                         | 31<br>32                         | 00           | 15  | 03  | 04                   | 0C                   | 02                   | 0A                   | 06                   | 81                   | 07     | 1/1         | 1/2    | 1/-  | 2    | 1 |
| Channel balance   | CB     | -1.5 | 0    | 1.5  | dB    | Lch reference  | -                                | -                                | -            | -   | -   | -                    | -                    | -                    | -                    | -                    | -                    | -      | -           | -      | -    | -    | - |
| Selector A-C Input impedance                                  | RIN    | 35   | 50   | 65   | kΩ    |  | 41<br>42<br>43<br>44<br>45<br>46 | 41<br>42<br>43<br>44<br>45<br>46 | -            | -   | -   | -                    | -                    | -                    | -                    | -                    | -                    | -      | 1<br>2<br>3 | 1      | 2    | 2    | 1 |
| Selector D Input impedance                                    | RIND   | 10   | 20   | 30   | kΩ    |  | 47<br>48                         | 47<br>48                         | -            | -   | -   | -                    | -                    | -                    | -                    | -                    | -                    | -      | 4<br>4      | 1      | 2    | 2    | 1 |
| Maximum attenuation *   | ATTMAX | 86   | 95   | -    | dB    | DIN AUDIO  | 41<br>42                         | 32<br>31                         | F8           | 05  | 03  | 04                   | 0C                   | 02                   | 0A                   | 06                   | 81                   | 07     | 1           | 1      | 1    | 2    | 1 |
| Vocal fade suppression quantity                               | GVF    | 25   | 30   | -    | dB    |  | 41,42<br>41,42                   | 32<br>31                         | 00           | 25  | 03  | 04                   | 0C                   | 02                   | 0A                   | 06                   | 81                   | 07     | 1           | 1      | 1    | 2    | 1 |
| Graphic equalizer boost gain set error (Set 2dB, 4dB, 6dB)    | VGQBL  | -2   | 0    | 2    | dB    | VIN=100mVrms, fin=100Hz, 300Hz, 1kHz, 3kHz, or 10kHz | 41<br>42                         | 32<br>31                         | 00           | 05  | 03  | 74<br>04<br>04<br>04 | 0C<br>7C<br>0C<br>0C | 02<br>02<br>72<br>02 | 0A<br>0A<br>0A<br>7A | 06<br>06<br>06<br>06 | 81                   | 07     | 1           | 1      | 1    | 2    | 1 |
| Graphic equalizer boost gain set error (Set 8dB, 10dB, 12dB)  | VGQBH  | -3   | 0    | 3    | dB    | VIN=100mVrms, fin=100Hz, 300Hz, 1kHz, 3kHz, or 10kHz | 41<br>42                         | 32<br>31                         | 00           | 05  | 03  | 74<br>04<br>04<br>04 | 0C<br>7C<br>0C<br>0C | 02<br>02<br>72<br>02 | 0A<br>0A<br>0A<br>7A | 06<br>06<br>06<br>06 | 81                   | 07     | 1           | 1      | 1    | 2    | 1 |
| Graphic equalizer cut gain set error (Set -2dB, -4dB, -6dB)   | VGQCL  | -2   | 0    | 2    | dB    | VIN=100mVrms, fin=100Hz, 300Hz, 1kHz, 3kHz, or 10kHz | 41<br>42                         | 32<br>31                         | 00           | 05  | 03  | E4<br>04<br>04<br>04 | 0C<br>EC<br>0C<br>0C | 02<br>02<br>02<br>02 | 0A<br>0A<br>0A<br>EA | 06<br>06<br>06<br>06 | 81                   | 07     | 1           | 1      | 1    | 2    | 1 |
| Graphic equalizer cut gain set error (Set -8dB, -10dB, -12dB) | VGQCL  | -3   | 0    | 3    | dB    | VIN=100mVrms, fin=100Hz, 300Hz, 1kHz, 3kHz, or 10kHz | 41<br>42                         | 32<br>31                         | 00           | 05  | 03  | E4<br>04<br>04<br>04 | 0C<br>EC<br>0C<br>0C | 02<br>02<br>02<br>02 | 0A<br>0A<br>0A<br>EA | 06<br>06<br>06<br>06 | 81                   | 07     | 1           | 1      | 1    | 2    | 1 |
| Graphic equalizer channel balance                             | GQCB   | -1.5 | 0    | 1.5  | dB    | Lch reference  | -                                | -                                | -            | -   | -   | -                    | -                    | -                    | -                    | -                    | -                    | -      | -           | -      | -    | -    | - |
| Dynamic bass boost gain                                       | VBB    | 15   | 18   | 21   | dB    | VIN=40mVrms, fin=75Hz, 49pin=GND                     | 41,42<br>41,42                   | 32<br>31                         | 00           | E5  | 03  | 04                   | 0C                   | 02                   | 0A                   | 06                   | 81                   | 07     | 1           | 1      | 1    | 2    | 2 |
| Dynamic bass boost channel balance                            | VBCB   | -1.5 | 0    | 1.5  | dB    | Lch reference  | -                                | -                                | -            | -   | -   | -                    | -                    | -                    | -                    | -                    | -                    | -      | -           | -      | -    | -    | - |
| Input separation *  | CTIN   | 80   | 90   | -    | dB    | DIN AUDIO  | 41<br>42                         | 51<br>52                         | 00           | 05  | 03  | 04                   | 0C                   | 02                   | 0A                   | 06                   | 41<br>C1<br>81       | 07     | 1           | 1      | 1    | 2    | 1 |
| Input mute attenuation *                                      | VINMU  | 80   | 90   | -    | dB    | DIN AUDIO  | 41<br>42                         | 32<br>31                         | 00           | 05  | 03  | 04                   | 0C                   | 02                   | 0A                   | 06                   | 01                   | 07     | 1           | 1      | 1    | 2    | 1 |
| Microphone voltage gain                                       | GMIC   | 17   | 19   | 21   | dB    | VIN=100mVrms   | 56                               | 32<br>31                         | 00           | 05  | 03  | 04                   | 0C                   | 02                   | 0A                   | 06                   | 81                   | 07     | 1           | 2      | -    | 1    | 1 |
| Microphone mute attenuation *                                 | VMICMU | 80   | 90   | -    | dB    | VIN=100mVrms, DIN AUDIO                              | 56                               | 32<br>31                         | 00           | 15  | 03  | 04                   | 0C                   | 02                   | 0A                   | 06                   | 81                   | 07     | 1           | 2      | -    | 1    | 1 |
| RECOU voltage gain  | GREC   | 9    | 11   | 13   | dB    |  | 41<br>42                         | 51<br>52                         | 00           | 05  | 03  | 04                   | 0C                   | 02                   | 0A                   | 06                   | 81                   | 07     | 1           | 1      | 1    | 2    | 1 |
| RECOU mute attenuation *                                      | VRECMU | 80   | 90   | -    | dB    | DIN AUDIO  | 41<br>42                         | 51<br>52                         | 00           | 0D  | 03  | 04                   | 0C                   | 02                   | 0A                   | 06                   | 81                   | 07     | 1           | 1      | 1    | 2    | 1 |
| Selector D attenuation  | D2ATT  | -7   | -9   | -11  | dB    |  | 49<br>50                         | 32<br>31                         | 00           | 05  | 03  | 04                   | 0C                   | 02                   | 0A                   | 06                   | E1                   | 07     | 4           | 1      | 1    | 2    | 1 |
| Surround maximum voltage gain                                 | VSUMAX | 7    | 9    | 11   | dB    | VIN=100mVrms, fin=10kHz                              | 41<br>42                         | 32<br>31                         | 00           | 05  | 1B  | 04                   | 0C                   | 02                   | 0A                   | 06                   | 81                   | 07     | 1           | 1      | 1    | 2    | 1 |

© Design against radiation-proof is not made.

\* VP-9690A (Average value detection, effective value display) DIN AUDIO filter by Matsushita Communication is used for \* measurement.

## Audio ICs

| Parameter                                 | Symbol | Min. | Typ. | Max. | Unit | Conditions  | Input pin      | Measurement pin | Data setting |     |     |     |     |     |     |     | Switch control table |                            |                   |                   |                   |                 |                 |
|---|--------|------|------|------|------|---|----------------|-----------------|--------------|-----|-----|-----|-----|-----|-----|-----|----------------------|----------------------------|-------------------|-------------------|-------------------|-----------------|-----------------|
|   |        |      |      |      |      |   |                |                 | [1]          | [2] | [3] | [4] | [4] | [5] | [5] | [6] | [7]                  | [8]                        | SW <sub>1/4</sub> | SW <sub>2/5</sub> | SW <sub>3/6</sub> | SW <sub>7</sub> | SW <sub>8</sub> |
| Simulated stereo maximum voltage gain Lch | VMONL  | 6.5  | 8.5  | 10.5 | dB   | V <sub>IN</sub> =100mVrms<br>f <sub>IN</sub> =680Hz                                   | 41,42<br>41,42 | 32<br>31        | 00           | 05  | 1B  | 04  | 0C  | 02  | 0A  | 06  | 91                   | 07                         | 1                 | 1                 | 1                 | 2               | 1               |
| Simulated stereo maximum voltage gain Rch | VMONR  | 11.3 | 13.3 | 15.3 | dB   | V <sub>IN</sub> =100mVrms<br>f <sub>IN</sub> =680Hz                                   |                |                 |              |     |     |     |     |     |     |     |                      |                            |                   |                   |                   |                 |                 |
| Spectrum analyzer maximum output level    | VMAX   | 4.0  | 4.8  | -    | V    | V <sub>IN</sub> =-19dBV   | 41,42<br>41,42 | 39              | 00           | 05  | 03  | 04  | 0C  | 02  | 0A  | 06  | 81                   | 47<br>C7<br>27<br>A7<br>67 | 1                 | 1                 | 1                 | 2               | 1               |
| Spectrum analyzer output offset voltage   | VOS    | 0    | 30   | 200  | mV   | V <sub>IN</sub> =0Vrms  | -              | 39              | 00           | 05  | 03  | 04  | 0C  | 02  | 0A  | 06  | 81                   | 47<br>C7<br>27<br>A7<br>67 | -                 | -                 | -                 | -               | -               |
| Spectrum analyzer standard output level   | VST    | 0.65 | 1.35 | 1.7  | V    | V <sub>IN</sub> =-37dBV<br>f <sub>IN</sub> =105Hz, 340Hz, 1kHz,<br>3.4kHz, or 10.5kHz | 41,42<br>41,42 | 39              | 00           | 05  | 03  | 04  | 0C  | 02  | 0A  | 06  | 81                   | 47<br>C7<br>27<br>A7<br>67 | 1                 | 1                 | 1                 | 2               | 1               |
| Ripple rejection *                        | RR     | 31   | -    | -    | dB   | V <sub>RR</sub> =100mVrms<br>f <sub>RR</sub> =100Hz, DIN AUDIO                        | 30             | 32<br>31        | 00           | 15  | 03  | 04  | 0C  | 02  | 0A  | 06  | 81                   | 07                         | 1                 | 2                 | -                 | 2               | 1               |

© Design against radiation-proof is not made.

\* VP-9690A (Average value detection, effective value display) DIN AUDIO filter by Matsushita Communication is used for \* measurement.



## Audio ICs

## ●Circuit operations

## Timing of Control Signal

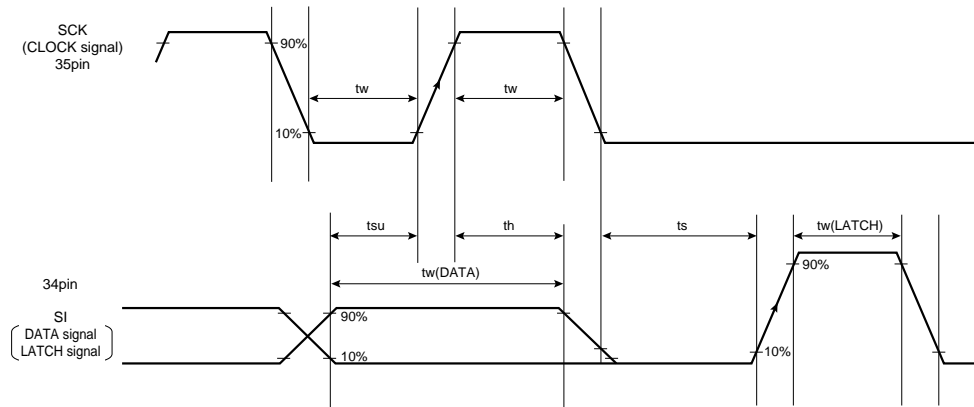

Fig.2

DATA (SI) is read at a rising edge of CLOCK.

DATA is fixed by the rising edge of LATCH.

Be sure to set SCK and SI to Low after latching.

When the CLOCK signal is High, it doesn't accept LATCH signal.

Constant of Timing Chart ( $T_a=25^\circ\text{C}$ )

| Parameter                      | Symbol              | Min. | Typ. | Max. | Unit          |
|--------------------------------|---------------------|------|------|------|---------------|
| "High" Input voltage           | $V_{IH}$            | 3.3  | 5.0  | 6.0  | V             |
| "Middle" Input voltage         | $V_{IM}$            | 1.8  | 2.0  | 2.4  | V             |
| "Low" Input voltage            | $V_{IL}$            | -0.3 | 0    | 1.2  | V             |
| Clock width                    | $t_w$               | 2.0  | -    | -    | $\mu\text{s}$ |
| Data width                     | $t_w(\text{DATA})$  | 4.0  | -    | -    | $\mu\text{s}$ |
| Latch width                    | $t_w(\text{LATCH})$ | 2.0  | -    | -    | $\mu\text{s}$ |
| Setup time (DATA→CLOCK)        | $t_{su}$            | 1.0  | -    | -    | $\mu\text{s}$ |
| Hold time (CLOCK→CLOCK)        | $t_h$               | 1.0  | -    | -    | $\mu\text{s}$ |
| Setup time (DATA, CLOCK→LATCH) | $t_s$               | 1.0  | -    | -    | $\mu\text{s}$ |

\* Serial signal SI is judging DATA and LATCH in the difference of the voltage level.

\* In the application schematic, it is changing 0-5V 3 line serial data into the 2 line serial data at the voltage with the resistance and the diode of the external.

We request enough examination, because there is a case where the voltage which is changed by the ability for the microcomputer to drive and the external parts.

Audio ICs

When transmitting more than one piece of data at once, we request the following serial control transmission.

(1) Timing of serial data and latch

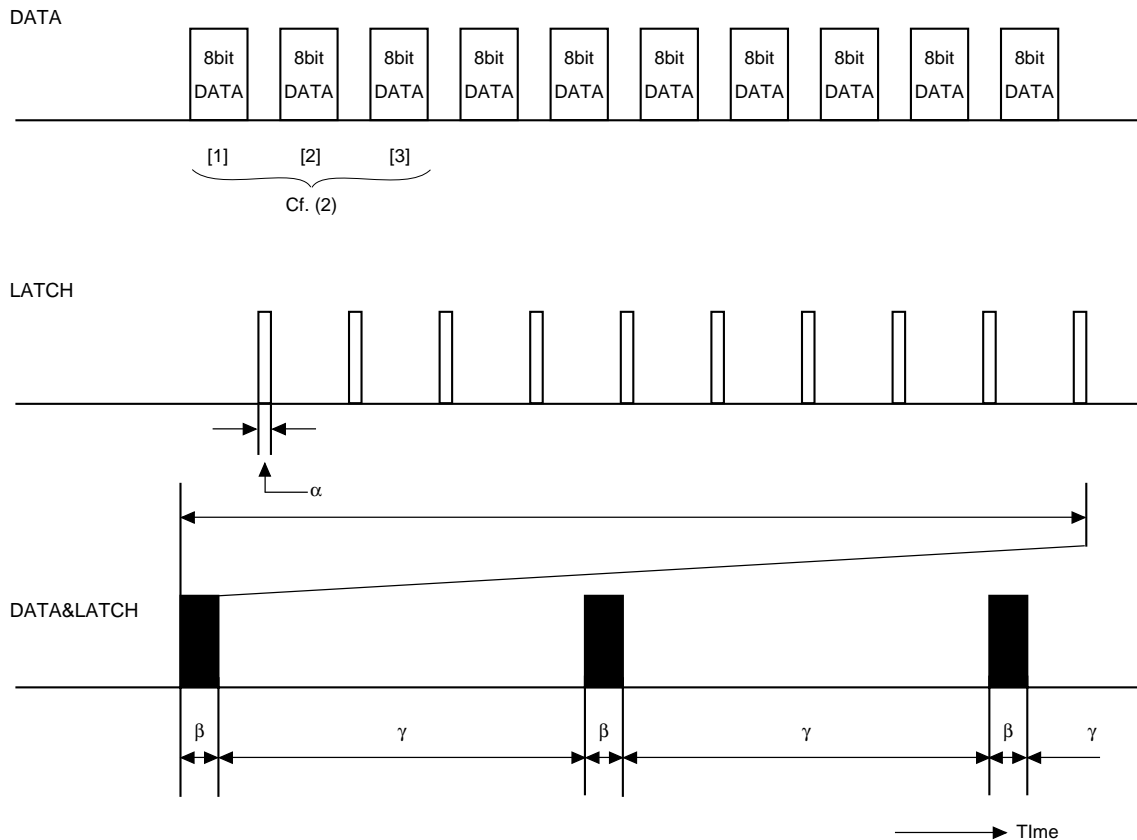

Fig.3

|          | Parameter  | Time                  |
|----------|--|-----------------------|
| $\alpha$ | Latch width  | More than 2.0 $\mu$ s |
| $\beta$  | The time which transmits more than one piece of data at once   | Less than 2.5ms       |
| $\gamma$ | The time which sends more than one piece of the following data after sending more than one piece of data (When the capacitor of 33 pin is 0.22 $\mu$ F.) | More than 100ms       |

(2) About the order which transmits more than one piece of DATA at once

When transmitting more than one piece of DATA including [1], [2] or [3] at once, transmit DATA of [1], [2] or [3] of the data format first.

In case of transmitting some data from [1] until [8], transmit only necessary DATA in order from [1].

(3) About DATA needing the timing of (1)

DATA needing the timing of (1) are DATA [1], [2] and [3]. Even if one data of DATA [1], [2] and [3] is transmitted, follow the timing of (1).

In case of transmitting some data from [4] until [8], the timing of (1) need not be followed. In the case, there are no problems if the constant of timing chart in the preceding page is satisfied.

## Audio ICs

---

### (4) Relation of the serial data and 33pin capacitor

The interval  $\gamma$  of the data and the data can be more shortly set by changing the capacitor of 33pins.  
(Ex. When making the changing speed of VOLUME faster)

The relation between the interval  $\gamma$  of the data and the data and the capacitor of 33pin is as follows.

| 33pin Capacitor | The interval of the data and the next data |
|-----------------|--|
| 0.047 $\mu$ F   | More than 25ms                             |
| 0.1 $\mu$ F     | More than 50ms                             |
| 0.22 $\mu$ F    | More than 100ms                            |

Note: It is possible to do the interval of the data and the next data more shortly by changing 33pin capacitor into 0.047 $\mu$ F. However, the switching sound becomes rather bigger than the switching sound of setting 0.1 $\mu$ F about the switching sound of VOLUME, DBASS, SURROUND, MODE SELECTOR.

### (5) Others

If there is common impedance in GND of the IC, the switching sound something occurs by changing the mode.  
Wiring pattern of SI and SCK shall be away from that of analog unit and cross talk shall not be acceptable.

## Audio ICs

## SERIAL CONTROL DATA FORMAT

|     | D00                         | D01 | D02 | D03                  | D04                        | D05 | D06 | D07 |
|-----|-----------------------------|-----|-----|----------------------|----------------------------|-----|-----|-----|
| [1] | ● VOLUME                    |     |     |                      |                            | 0   | 0   | 0   |
|     | D10                         | D11 | D12 | D13                  | D14                        | D15 | D16 | D17 |
| [2] | ● MODE SELECTOR             |     |     | MIC                  | REC<br>OUT                 | 1   | 0   | 1   |
|     | D20                         | D21 | D22 | D23                  | D24                        | D25 | D26 | D27 |
| [3] | ● DYNAMIC BASS / Biamp      |     |     | ● SURROUND EFFECT    |                            | 0   | 1   | 1   |
|     | D30                         | D31 | D32 | D33                  | D34                        | D35 | D36 | D37 |
| [4] | ▲ GRAPHIC EQUALIZER f1 / f2 |     |     |                      | GREQ<br>0 : f1<br>1 : f2   | 1   | 0   | 0   |
|     | D40                         | D41 | D42 | D43                  | D44                        | D45 | D46 | D47 |
| [5] | ▲ GRAPHIC EQUALIZER f3 / f4 |     |     |                      | GREQ<br>0 : f3<br>1 : f4   | 0   | 1   | 0   |
|     | D50                         | D51 | D52 | D53                  | D54                        | D55 | D56 | D57 |
| [6] | ▲ GRAPHIC EQUALIZER f5      |     |     |                      | DPL<br>0 : OFF<br>1 : ON   | 1   | 1   | 0   |
|     | D60                         | D61 | D62 | D63                  | D64                        | D65 | D66 | D67 |
| [7] | INPUT SELECTOR              |     |     | SURROUND<br>/ STEREO | DYNAMIC<br>BASS<br>/ Biamp | 0   | 0   | 1   |
|     | D70                         | D71 | D72 | D73                  | D74                        | D75 | D76 | D77 |
| [8] | SPECTRUM ANALYZER           |     |     | *                    | *                          | 1   | 1   | 1   |

\* Don't Care

As for functions of the ● and ▲ mark, measures to reduce step noise are done.  
 Because the functions of no marks have no measures of step noise, please supply mute.  
 As for the ● mark, it becomes a soft switch method.  
 As for the ▲ mark, it takes measures to decrease DC offset voltage.



## Audio ICs

[1] VOLUME ATTENUATION

| ATT quantity | D00 | D01 | D02 | D03 | D04 | D05 | D06 | D07 |
|--------------|-----|-----|-----|-----|-----|-----|-----|-----|
| 0.0dB        | 0   | 0   | 0   | 0   | 0   | 0   | 0   | 0   |
| -2.0dB       | 1   | 0   | 0   | 0   | 0   |     |     |     |
| -4.0dB       | 0   | 1   | 0   | 0   | 0   |     |     |     |
| -6.0dB       | 1   | 1   | 0   | 0   | 0   |     |     |     |
| -8.0dB       | 0   | 0   | 1   | 0   | 0   |     |     |     |
| -10.0dB      | 1   | 0   | 1   | 0   | 0   |     |     |     |
| -12.0dB      | 0   | 1   | 1   | 0   | 0   |     |     |     |
| -14.0dB      | 1   | 1   | 1   | 0   | 0   |     |     |     |
| -16.0dB      | 0   | 0   | 0   | 1   | 0   |     |     |     |
| -18.0dB      | 1   | 0   | 0   | 1   | 0   |     |     |     |
| -20.0dB      | 0   | 1   | 0   | 1   | 0   |     |     |     |
| -22.0dB      | 1   | 1   | 0   | 1   | 0   |     |     |     |
| -24.0dB      | 0   | 0   | 1   | 1   | 0   |     |     |     |
| -26.0dB      | 1   | 0   | 1   | 1   | 0   |     |     |     |
| -28.0dB      | 0   | 1   | 1   | 1   | 0   |     |     |     |
| -30.0dB      | 1   | 1   | 1   | 1   | 0   |     |     |     |
| -32.0dB      | 0   | 0   | 0   | 0   | 1   |     |     |     |
| -34.0dB      | 1   | 0   | 0   | 0   | 1   |     |     |     |
| -36.0dB      | 0   | 1   | 0   | 0   | 1   |     |     |     |
| -38.0dB      | 1   | 1   | 0   | 0   | 1   |     |     |     |
| -40.0dB      | 0   | 0   | 1   | 0   | 1   |     |     |     |
| -44.0dB      | 1   | 0   | 1   | 0   | 1   |     |     |     |
| -48.0dB      | 0   | 1   | 1   | 0   | 1   |     |     |     |
| -52.0dB      | 1   | 1   | 1   | 0   | 1   |     |     |     |
| -56.0dB      | 0   | 0   | 0   | 1   | 1   |     |     |     |
| -60.0dB      | 1   | 0   | 0   | 1   | 1   |     |     |     |
| -64.0dB      | 0   | 1   | 0   | 1   | 1   |     |     |     |
| -68.0dB      | 1   | 1   | 0   | 1   | 1   |     |     |     |
| -72.0dB      | 0   | 0   | 1   | 1   | 1   |     |     |     |
| -76.0dB      | 1   | 0   | 1   | 1   | 1   |     |     |     |
| -82.0dB      | 0   | 1   | 1   | 1   | 1   |     |     |     |
| -∞           | 1   | 1   | 1   | 1   | 1   |     |     |     |

## Audio ICs

## [2] MODE SELECTOR, MIC, REC OUT

| MODE         | D10 | D11 | D12 | D13                     | D14                            | D15 | D16 | D17 |
|--------------|-----|-----|-----|-------------------------|--------------------------------|-----|-----|-----|
| THROUGH      | 0   | 0   | 0   | MIC<br>0: ON<br>1: MUTE | REC<br>OUT<br>0: ON<br>1: MUTE | 1   | 0   | 1   |
| THROUGH      | 1   | 0   | 0   |                         |                                |     |     |     |
| THROUGH      | 0   | 1   | 0   |                         |                                |     |     |     |
| THROUGH      | 1   | 1   | 0   |                         |                                |     |     |     |
| VOCAL FADE   | 0   | 0   | 1   |                         |                                |     |     |     |
| Lch MONAULAL | 1   | 0   | 1   |                         |                                |     |     |     |
| Rch MONAULAL | 0   | 1   | 1   |                         |                                |     |     |     |
| L+R          | 1   | 1   | 1   |                         |                                |     |     |     |

Note : About input selector, mode selector is cleared when MUTE of the input selector is chosen.  
When MUTE of the input selector is canceled, choose the mode selector, too.  
The MUTE command of the input selector has priority over the command of the mode selector.

## [3] Dynamic Bass / Biamp Effect, Surround Effect

## (a) Dynamic Bass / Biamp Effect

The effect quantity in biamp is different from the value of the below table.

| GAIN | D20 | D21 | D22 | D23                             | D24 | D25 | D26 | D27 |
|------|-----|-----|-----|---------------------------------|-----|-----|-----|-----|
| 0dB  | 0   | 0   | 0   | Refer to the<br>Surround Effect |     | 0   | 1   | 1   |
| 0dB  | 1   | 0   | 0   |                                 |     |     |     |     |
| 3dB  | 0   | 1   | 0   |                                 |     |     |     |     |
| 6dB  | 1   | 1   | 0   |                                 |     |     |     |     |
| 9dB  | 0   | 0   | 1   |                                 |     |     |     |     |
| 12dB | 1   | 0   | 1   |                                 |     |     |     |     |
| 15dB | 0   | 1   | 1   |                                 |     |     |     |     |
| 18dB | 1   | 1   | 1   |                                 |     |     |     |     |

## (b) Surround Effect

The effect quantity in simulated stereo mode is different from the value of the below table.

| GAIN | D20                                 | D21 | D22 | D23 | D24 | D25 | D26 | D27 |
|------|-------------------------------------|-----|-----|-----|-----|-----|-----|-----|
| 0dB  | Refer to the<br>Dynamic Bass Effect |     |     | 0   | 0   | 0   | 1   | 1   |
| 3dB  |                                     |     |     | 1   | 0   |     |     |     |
| 6dB  |                                     |     |     | 0   | 1   |     |     |     |
| 9dB  |                                     |     |     | 1   | 1   |     |     |     |

Note : GAIN is the name given to the transfer data.  
Depending on the values of the external constant, the specified gain may not be output.

## Audio ICs

[4] Graphic Equalizer f1 / f2

| GAIN  | D30 | D31 | D32 | D33 | D34                                | D35 | D36 | D37 |
|-------|-----|-----|-----|-----|------------------------------------|-----|-----|-----|
| +12dB | 1   | 1   | 1   | 1   | GREQ<br>SELECT<br>0 : f1<br>1 : f2 | 1   | 0   | 0   |
| +12dB | 0   | 1   | 1   | 1   |                                    |     |     |     |
| +10dB | 1   | 0   | 1   | 1   |                                    |     |     |     |
| +8dB  | 0   | 0   | 1   | 1   |                                    |     |     |     |
| +6dB  | 1   | 1   | 0   | 1   |                                    |     |     |     |
| +4dB  | 0   | 1   | 0   | 1   |                                    |     |     |     |
| +2dB  | 1   | 0   | 0   | 1   |                                    |     |     |     |
| 0dB   | 0   | 0   | 0   | 1   |                                    |     |     |     |
| 0dB   | 0   | 0   | 0   | 0   |                                    |     |     |     |
| -2dB  | 1   | 0   | 0   | 0   |                                    |     |     |     |
| -4dB  | 0   | 1   | 0   | 0   |                                    |     |     |     |
| -6dB  | 1   | 1   | 0   | 0   |                                    |     |     |     |
| -8dB  | 0   | 0   | 1   | 0   |                                    |     |     |     |
| -10dB | 1   | 0   | 1   | 0   |                                    |     |     |     |
| -12dB | 0   | 1   | 1   | 0   |                                    |     |     |     |
| -12dB | 1   | 1   | 1   | 0   |                                    |     |     |     |

Note : GAIN is the name given to the transfer data.  
Depending on the values of the external constant, the specified gain may not be output.

[5] Graphic Equalizer f3 / f4

| GAIN  | D40 | D41 | D42 | D43 | D44                                | D45 | D46 | D47 |
|-------|-----|-----|-----|-----|------------------------------------|-----|-----|-----|
| +12dB | 1   | 1   | 1   | 1   | GREQ<br>SELECT<br>0 : f3<br>1 : f4 | 0   | 1   | 0   |
| +12dB | 0   | 1   | 1   | 1   |                                    |     |     |     |
| +10dB | 1   | 0   | 1   | 1   |                                    |     |     |     |
| +8dB  | 0   | 0   | 1   | 1   |                                    |     |     |     |
| +6dB  | 1   | 1   | 0   | 1   |                                    |     |     |     |
| +4dB  | 0   | 1   | 0   | 1   |                                    |     |     |     |
| +2dB  | 1   | 0   | 0   | 1   |                                    |     |     |     |
| 0dB   | 0   | 0   | 0   | 1   |                                    |     |     |     |
| 0dB   | 0   | 0   | 0   | 0   |                                    |     |     |     |
| -2dB  | 1   | 0   | 0   | 0   |                                    |     |     |     |
| -4dB  | 0   | 1   | 0   | 0   |                                    |     |     |     |
| -6dB  | 1   | 1   | 0   | 0   |                                    |     |     |     |
| -8dB  | 0   | 0   | 1   | 0   |                                    |     |     |     |
| -10dB | 1   | 0   | 1   | 0   |                                    |     |     |     |
| -12dB | 0   | 1   | 1   | 0   |                                    |     |     |     |
| -12dB | 1   | 1   | 1   | 0   |                                    |     |     |     |

Note : GAIN is the name given to the transfer data.  
Depending on the values of the external constant, the specified gain may not be output.

## Audio ICs

## [6] Graphic Equalizer f5, DPL

| GAIN  | D50 | D51 | D52 | D53 | D54                                | D55 | D56 | D57 |
|-------|-----|-----|-----|-----|------------------------------------|-----|-----|-----|
| +12dB | 1   | 1   | 1   | 1   | DPL<br>SELECT<br>0 : OFF<br>1 : ON | 1   | 1   | 0   |
| +12dB | 0   | 1   | 1   | 1   |                                    |     |     |     |
| +10dB | 1   | 0   | 1   | 1   |                                    |     |     |     |
| +8dB  | 0   | 0   | 1   | 1   |                                    |     |     |     |
| +6dB  | 1   | 1   | 0   | 1   |                                    |     |     |     |
| +4dB  | 0   | 1   | 0   | 1   |                                    |     |     |     |
| +2dB  | 1   | 0   | 0   | 1   |                                    |     |     |     |
| 0dB   | 0   | 0   | 0   | 1   |                                    |     |     |     |
| 0dB   | 0   | 0   | 0   | 0   |                                    |     |     |     |
| -2dB  | 1   | 0   | 0   | 0   |                                    |     |     |     |
| -4dB  | 0   | 1   | 0   | 0   |                                    |     |     |     |
| -6dB  | 1   | 1   | 0   | 0   |                                    |     |     |     |
| -8dB  | 0   | 0   | 1   | 0   |                                    |     |     |     |
| -10dB | 1   | 0   | 1   | 0   |                                    |     |     |     |
| -12dB | 0   | 1   | 1   | 0   |                                    |     |     |     |
| -12dB | 1   | 1   | 1   | 0   |                                    |     |     |     |

Note : GAIN is the name given to the transfer data.  
Depending on the values of the external constant, the specified gain may not be output.

## [7] Input Selector, Dynamic Bass / Biamp, Surround / Simulated stereo

| INPUT  | D60 | D61 | D62 | D63                                     | D64                              | D65 | D66 | D67 |
|--|-----|-----|-----|---|----------------------------------|-----|-----|-----|
| MUTE   | 0   | 0   | 0   | 0 : Surround<br>1 : Simulated<br>stereo | 0 : Dynamic<br>Bass<br>1 : Biamp | 0   | 0   | 1   |
| INPUT-LA, INPUT-RA                                   | 1   | 0   | 0   |   |                                  |     |     |     |
| INPUT-LB, INPUT-RB                                   | 0   | 1   | 0   |   |                                  |     |     |     |
| INPUT-LC, INPUT-RC                                   | 1   | 1   | 0   |   |                                  |     |     |     |
| MUTE   | 0   | 0   | 1   |   |                                  |     |     |     |
| MUTE   | 1   | 0   | 1   |   |                                  |     |     |     |
| INPUT-LD <sub>1</sub> , INPUT-RD <sub>1</sub> (0dB)  | 0   | 1   | 1   |   |                                  |     |     |     |
| INPUT-LD <sub>2</sub> , INPUT-RD <sub>2</sub> (-9dB) | 1   | 1   | 1   |   |                                  |     |     |     |

## [8] Spectrum Analyzer

| FREQUENCY                   | D70 | D71 | D72 | D73 | D74 | D75 | D76 | D77 |
|-----------------------------|-----|-----|-----|-----|-----|-----|-----|-----|
| RESET                       | 0   | 0   | 0   | *   | *   | 1   | 1   | 1   |
| RESET                       | 1   | 0   | 0   |     |     |     |     |     |
| fo=105Hz                    | 0   | 1   | 0   |     |     |     |     |     |
| fo=340Hz                    | 1   | 1   | 0   |     |     |     |     |     |
| fo=1kHz                     | 0   | 0   | 1   |     |     |     |     |     |
| fo=3.4kHz                   | 1   | 0   | 1   |     |     |     |     |     |
| fo=10.5kHz                  | 0   | 1   | 1   |     |     |     |     |     |
| Priority over parallel data | 1   | 1   | 1   |     |     |     |     |     |

\* Don't Care

Audio ICs

---

## PARALLEL CONTROL

| A<br>36pin | B<br>37pin | C<br>38pin | BPOUT<br>(39pin) |
|------------|------------|------------|------------------|
| 0          | 0          | 0          | RESET            |
| 0          | 0          | 1          | 105Hz            |
| 0          | 1          | 0          | 340Hz            |
| 0          | 1          | 1          | RESET            |
| 1          | 0          | 0          | 1kHz             |
| 1          | 0          | 1          | RESET            |
| 1          | 1          | 0          | 3.4kHz           |
| 1          | 1          | 1          | 10.5kHz          |

When serial control is done, a parallel control isn't received.

When the serial control is "parallel priority", a parallel control on the left is received.

When changing the frequency of spectrum analyzer, transmit the command of the following frequency after transmitting a reset command.

Audio ICs

● Application example

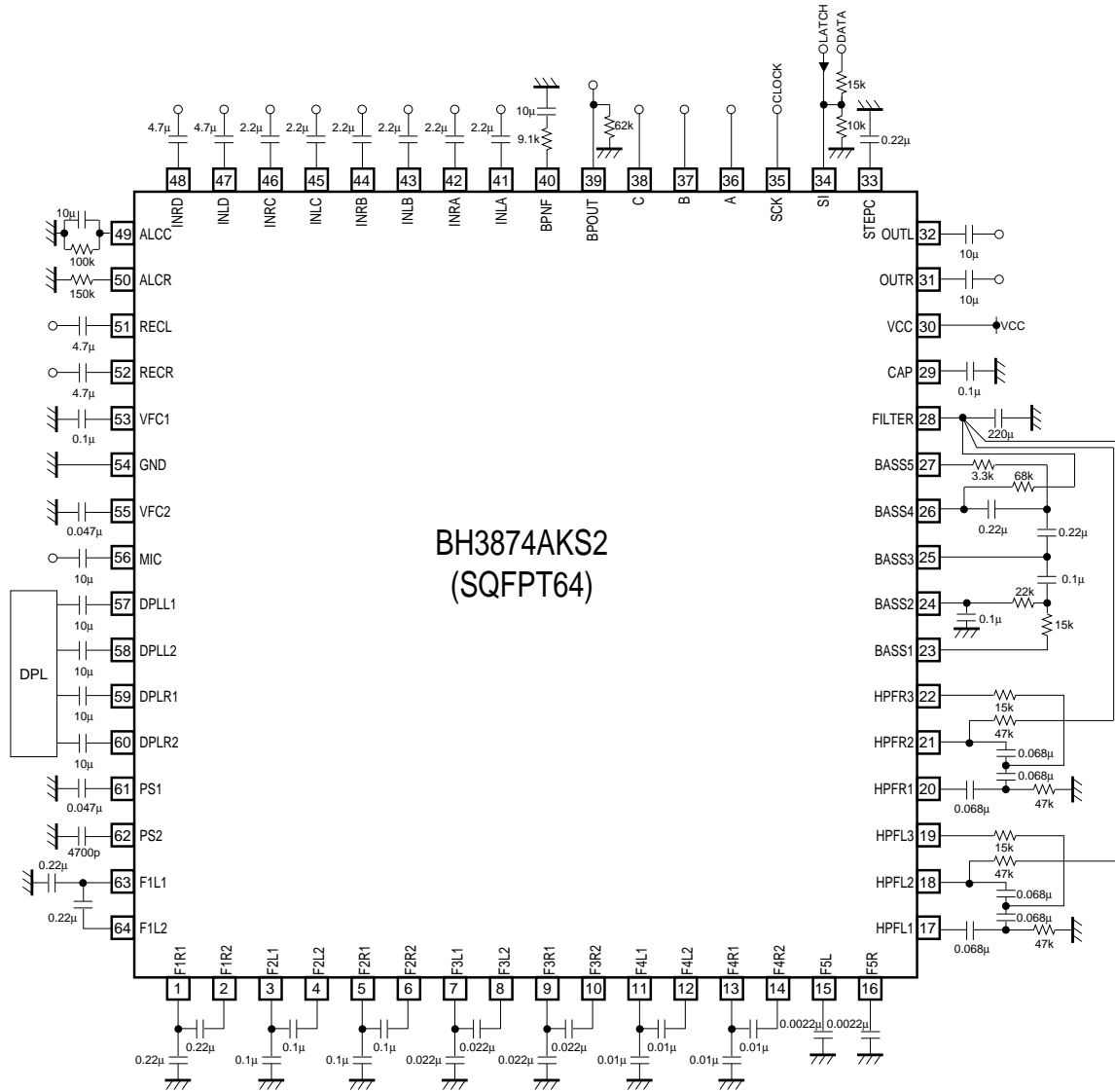

Fig.4

## Audio ICs

### ●Operation notes

#### (1) About operation voltage supply range

Within operation voltage supply range, basic circuit function operation is guaranteed within operation ambient temp. But please confirm set up constant and element, voltage set up and temp set up on use.

#### (2) About operation temp range.

If it within recommended operation voltage range, circuit function operation is guaranteed within operation temp. It correlated to conditions of power dissipation to temp.

Please watch out except condition stipulated by electrical characteristics within the range. It cannot guarantee standard value of electrical characteristics. But it retains original function.

#### (3) About Application circuit

Example of application circuit drawing is convinced as recommendable. But please confirm characteristic including above mentioned noticed.

At use with modification of external constant, please decide with enough margin considering distribution, ETC of this IC, external parts including quiescence characteristics and excessive characteristics.

Please note that we have not yet confirmed any concerned patent rights completely.

#### (4) About 2-wire serial control

High-frequency digital signal is inputted into the SCK terminal and SI terminal. So wire and print patterns suitably to prevent interference to analog signal system line (especially to input line).

#### (5) About ground line

Please connect IC's ground to the ground of a set with one point. When the IC has common impedance to the ground line, pop noise may occur in function switching.

#### (6) About Schmidt circuit

This IC has the Schmidt circuit as preventive measures against logic signal input into the DATA (34pin) and CLK (35pin) terminals. Therefore, this IC is not affected so much by noise to a logic signal line.

#### (7) About power on/off

At on of power supply or off of power supply pop noise occurs. Therefore, please supply mute.

#### (8) Setting of spectrum analyzer minimum light level

Output offset voltage may shift due to the surrounding conditions (temperature, stresses, etc.).

Therefore when setting the spectrum analyzer minimum light level, leave a margin (more than 30% to spectrum analyzer output offset voltage VOS).

### ●Electrical characteristic curves

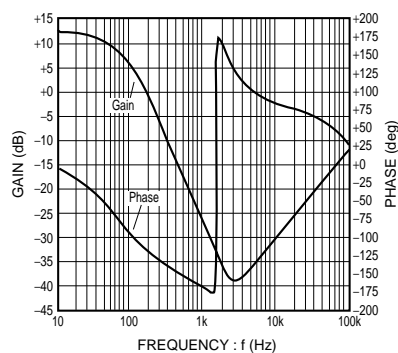

Fig.5 Vocal fade characteristics

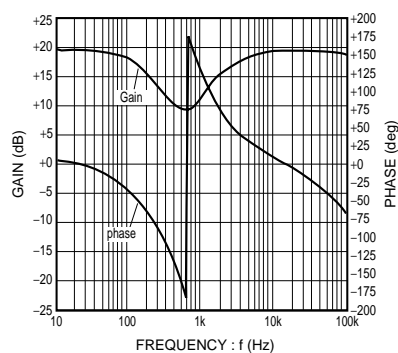

Fig.6 Surround characteristics

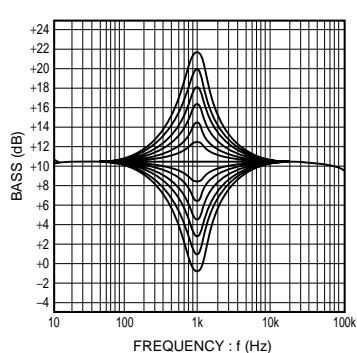

Fig.7 Graphic equalizer characteristics

Audio ICs

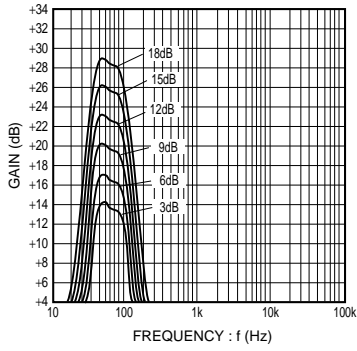

Fig.8 Biamp characteristics  
(Input common-mode)

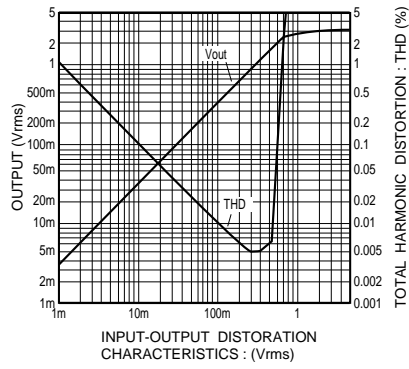
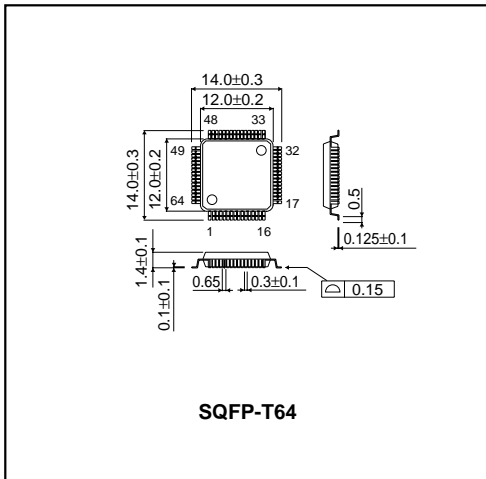

Fig.9 Input-output distortion  
characteristics

●External dimensions (Units : mm)





### Notes

- No technical content pages of this document may be reproduced in any form or transmitted by any means without prior permission of ROHM CO.,LTD.
- The contents described herein are subject to change without notice. The specifications for the product described in this document are for reference only. Upon actual use, therefore, please request that specifications to be separately delivered.
- Application circuit diagrams and circuit constants contained herein are shown as examples of standard use and operation. Please pay careful attention to the peripheral conditions when designing circuits and deciding upon circuit constants in the set.
- Any data, including, but not limited to application circuit diagrams information, described herein are intended only as illustrations of such devices and not as the specifications for such devices. ROHM CO.,LTD. disclaims any warranty that any use of such devices shall be free from infringement of any third party's intellectual property rights or other proprietary rights, and further, assumes no liability of whatsoever nature in the event of any such infringement, or arising from or connected with or related to the use of such devices.
- Upon the sale of any such devices, other than for buyer's right to use such devices itself, resell or otherwise dispose of the same, no express or implied right or license to practice or commercially exploit any intellectual property rights or other proprietary rights owned or controlled by
- ROHM CO., LTD. is granted to any such buyer.
- Products listed in this document use silicon as a basic material.  
Products listed in this document are no antiradiation design.

The products listed in this document are designed to be used with ordinary electronic equipment or devices (such as audio visual equipment, office-automation equipment, communications devices, electrical appliances and electronic toys).

Should you intend to use these products with equipment or devices which require an extremely high level of reliability and the malfunction of which would directly endanger human life (such as medical instruments, transportation equipment, aerospace machinery, nuclear-reactor controllers, fuel controllers and other safety devices), please be sure to consult with our sales representative in advance.

#### About Export Control Order in Japan

Products described herein are the objects of controlled goods in Annex 1 (Item 16) of Export Trade Control Order in Japan.

In case of export from Japan, please confirm if it applies to "objective" criteria or an "informed" (by MITI clause) on the basis of "catch all controls for Non-Proliferation of Weapons of Mass Destruction.