

# PWM driver for CD and MD players

## BH6504K

The BH6504K is a 4-channel PWM driver designed for CD and MD player motors and actuator drives. The power MOSFET output stage allows for applications with low power consumption. This IC also has a charge pump circuit and standard operational amplifier (needed for power MOSFET gate drives), and so supports a wide spectrum of applications.

### ● Applications

Portable CD players, MD players

### ● Features

- 1) Low power consumption.
- 2) A minimum of attached components.
- 3) Excellent gain precision because of the voltage feedback circuit.
- 4) Internal mute function for channel 1.
- 5) Allows for free-running and clock synchronization operation.
- 6) Internal standard operational amplifier.
- 7) Internal charge pump circuit for gate drive.
- 8) Switchable to doubled clock synchronization.

### ● Absolute maximum ratings (Ta = 25°C)

Parameter	Symbol	Limits	Unit
H bridge power supply voltage	Battery	7	V
Control circuit power supply voltage	Pre.Vcc	7	V
Predriver power supply voltage	VG (pin18)	7	V
Driver output current	Io	500	mA
Power dissipation	Pd	500*1	mW
Operating temperature	Topr	-30~+85	°C
Storage temperature	Tstg	-55~+125	°C

\*1 Reduced by 5.0 mW for each increase in Ta of 1°C over 25°C.

### ● Recommended operating conditions

Parameter	Symbol	Min.	Typ.	Max.	Unit
H bridge power supply voltage	Battery	1.6	2.4	4.5	V
Control circuit power supply voltage	Pre.Vcc	2.7	3.0	4.5	V
Predriver power supply voltage*2	VG (pin18)	Battery +1.6	6.5	6.9	V
Ambient temperature	Ta	-10	25	70	°C

\*2 When supplied from an external source without using the internal DC / DC converter



● Block diagram

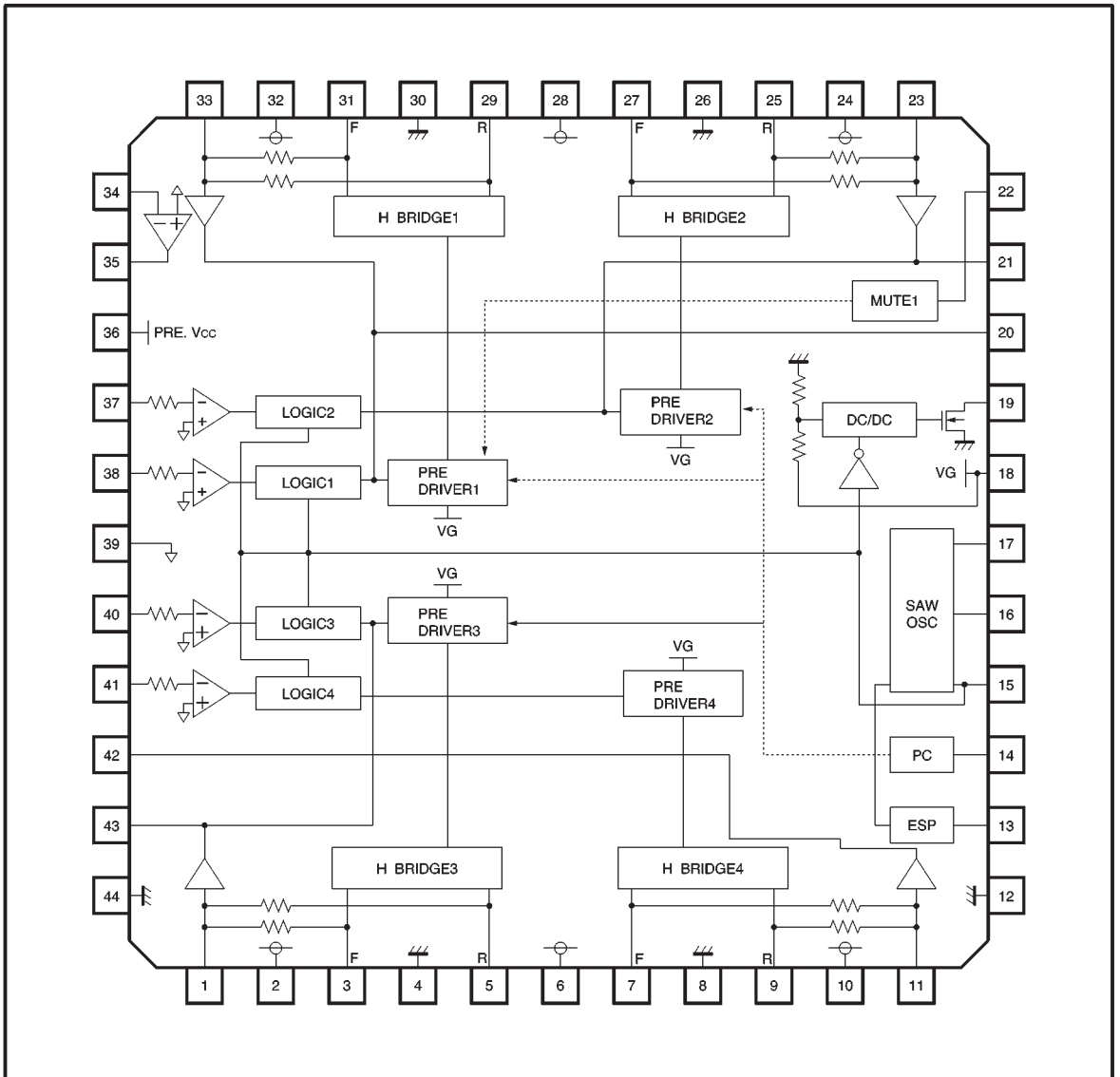

## ● Pin descriptions

Pin No.	Pin name	Function	Pin No.	Pin name	Function
1	CO3	Channel 3 voltage feedback filter	23	CO2	Channel 2 voltage feedback filter
2	BATT3	Power supply input	24	BATT2	Power supply input
3	OUT 3F	Channel 3 positive output	25	OUT 2R	Channel 2 negative output
4	POWGND	Power supply ground	26	POWGND	Power supply ground
5	OUT 3R	Channel 3 negative output	27	OUT 2F	Channel 2 positive output
6	BATT34	Power supply input	28	BATT12	Power supply input
7	OUT 4F	Channel 4 positive output	29	OUT 1R	Channel 1 negative output
8	POWGND	Power supply ground	30	POWGND	Power supply ground
9	OUT 4R	Channel 4 negative output	31	OUT 1F	Channel 1 positive output
10	BATT4	Power supply input	32	BATT1	Power supply input
11	CO4	Channel 4 voltage feedback filter	33	CO1	Channel 1 voltage feedback filter
12	D.GND	Pre-drive circuit supply ground	34	OP—	Negative input of the operational amplifier
13	ESP	Double-speed detection circuit	35	OP OUT	Operational amplifier output
14	PC	All-driver output mute	36	Pre.Vcc	Control circuit supply input
15	CT	Triangular wave output	37	ERR2	Channel 2 control signal input
16	RT	Charge current setting	38	ERR1	Channel 1 control signal input
17	CLK	External clock synchronization input	39	VC	Reference voltage input
18	VG	Pre-drive circuit supply input	40	ERR3	Channel 3 control signal input
19	LG	Attached DC / DC converter connection	41	ERR4	Channel 4 control signal input
20	CN1	Channel 1 phase compensation filter	42	CN4	Channel 4 phase compensation filter
21	CN2	Channel 2 phase compensation filter	43	CN3	Channel 3 phase compensation filter
22	CH1MUTE	Channel 1 mute	44	Pre.GND	Control circuit supply ground

Note: positive and negative output of the driver is relative to the polarity of the input pins.

● Input / output circuits

Pin name	Pin No.	Pin equivalent circuit
CO3 BATT3 OUT_3F POWGND OUT_3R BATT34	1 2 3 4 5 6	
OUT_4F POWGND OUT_4R BATT4 CO4	7 8 9 10 11	
D.GND	12	Predriver circuit ground pin
ESP	13	
PC	14	

Pin name	Pin No.	Pin equivalent circuit
CT RT	15 16	
CLK	17	
VG	18	Predriver circuit power supply pin
LG	19	
CN1 CN2 CN4 CN3	20 21 42 43	
MUTE1	22	

Pin name	Pin No.	Pin equivalent circuit
CO2 BATT2 OUT_2R POWGND OUT_2F BATT12	23 24 25 26 27 28	
OUT_1R POWGND OUT_1F BATT1 CO1	29 30 31 32 33	
OP_—	34	
OP_OUT	35	

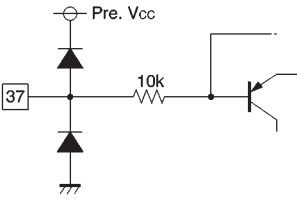
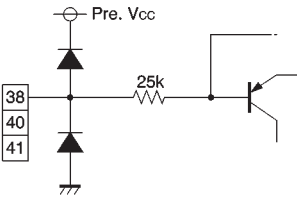
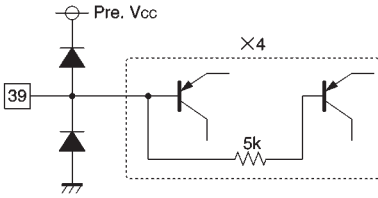
Pin name	Pin No.	Pin equivalent circuit
Pre.Vcc	36	Control circuit power supply pin
ERR2	37	
ERR1 ERR3 ERR4	38 40 41	
VC	39	
Pre.GND	44	Control circuit ground pin

## ● Electrical characteristics

(unless otherwise noted, Ta = 25°C, Battery = 2.4V, Pre.Vcc = 3.0V, Vc = 1.5V, fCLK = 176.4kHz, RL = 8Ω–47μH)

Parameter		Symbol	Min.	Typ.	Max.	Unit	Conditions
Standby current		IST	—	—	3	μA	Pre.Vcc=OFF
Quiescent current dissipation		ICC1	—	4.5	9	mA	Including DC / DC converter coil current
Operating current		ICC2	—	7	14	mA	4-channel drive Including DC / DC converter coil current
〈PWM driver〉							
CH1	Output-on resistance	RON	—	1.3	2.0	Ω	Sum of top and bottom on-resistance
	Input offset voltage	VOI	−5	0	5	mV	
CH3	Output offset voltage	VOO	−35	0	35	mV	
CH4	Voltage gain	GVC1–4	8.0	10.0	12.0	dB	
	Pos./neg. voltage gain differential	GVC	−1.5	0	1.5	dB	
CH2	Output ON resistance	RON	—	1.3	2.0	Ω	Sum of top and bottom ON resistance
	Input offset voltage	VOI	−5	0	5	mV	
	Output offset voltage	VOO	−35	0	35	mV	
	Voltage gain	GVC1–4	18.0	20.0	22.0	dB	
	Pos./neg. voltage gain differential	GVC	−1.5	0	1.5	dB	
〈DC / DC converter*1〉							
Output voltage		VG	6.1	6.5	6.9	V	
〈Triangular wave generator〉							
Free-running oscillation frequency 1		fOSC1	—	140	—	kHz	
Synchronization signal input frequency 11		fCLK11	75	88	100	kHz	RT=39kΩ, CT=220pF
Synchronization signal input frequency 12		fCLK12	150	176	200	kHz	
Free-running oscillation frequency 2		fOSC2	—	60	—	kHz	
Synchronization signal input frequency 21		fCLK21	38	44	50	kHz	RT=39kΩ, CT=470pF
Synchronization signal input frequency 22		fCLK22	75	88	100	kHz	
〈Operational amplifier〉							
Input bias current		IBIAS	—	—	300	nA	
Input offset voltage		VOIOP	−5.5	0	5.5	mV	
Output high level voltage		VOHOP	2.8	—	—	V	RL=OPEN
Output low level voltage		VOLOP	—	—	0.2	V	RL=OPEN
Output drive current (source)		ISOU	0.3	0.5	—	mA	50Ω at GND
Output drive current (sink)		ISIN	1	3	—	mA	50Ω at Vcc
Open loop voltage gain		GVO	—	70	—	dB	VIN=−75dBV, f=1kHz
Slew rate		SR	—	0.5	—	V/μs	
〈Control pin threshold〉							
MUTE1-ON level input voltage		VMTON	2.2	—	—	V	
MUTE1-OFF level input voltage		VMTOFF	—	—	0.5	V	
PC-ON level input voltage		VPCON	2.2	—	—	V	
PC-OFF level input voltage		VPCOFF	—	—	0.5	V	
ESP-ON level input voltage		VESPON	2.2	—	—	V	
ESP-OFF level input voltage		VESPOFF	—	—	0.5	V	

©Not designed for radiation resistance.

\*1 DC / DC converter circuit:

Pre.Vcc is raised to 6.5 V by attaching an inductance, Schottky barrier diode, and capacitor.

This voltage is then converted to 1.5V for the operation circuit.



● Measurement circuit

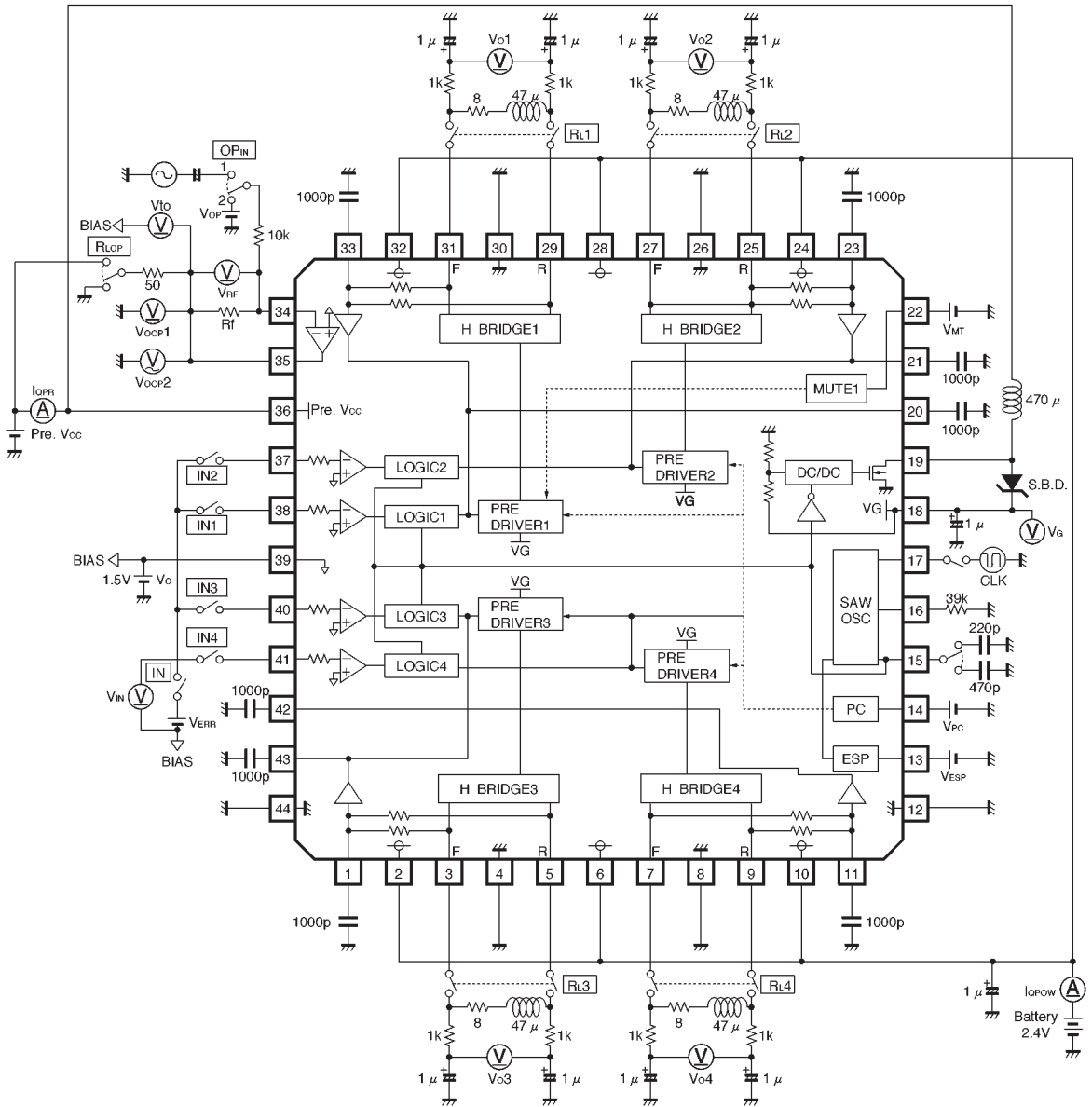

Fig. 1

## ● Measurement circuit switch tables

Parameter	V <sub>ERR</sub>	IN	RL	Notes	Measurement point
I <sub>ST</sub>	OFF	OFF	OFF	Pre.V <sub>CC</sub> =V <sub>C</sub> =OPEN, Battery=2.4V	I <sub>QPOW</sub>
I <sub>CC1</sub>	OFF	OFF	OFF		I <sub>QPR</sub>
I <sub>CC2</sub>	±0.5V	ON	OFF	Simultaneous 4-channel input	I <sub>QPR</sub>

## 〈PWM driver〉

Parameter	V <sub>ERR</sub>	IN	RL	Notes	Measurement point
R <sub>ON1~4</sub>	±1.5V	ON	ON	$R_{ON} = \frac{(\text{Battery} - V_{O1\sim4}) \times RL}{V_{O1\sim4}}$	V <sub>O1~4</sub>
V <sub>O1</sub>	OFF	OFF	ON		V <sub>O1~4</sub> , V <sub>IN</sub>
V <sub>CO</sub>	0V	ON	ON		V <sub>O1~4</sub>
G <sub>Vc1~4</sub>	±0.1 ~0.2	ON	ON	$G_V = 20 \log \left  \frac{V_{O1\sim4}}{0.1} \right $	V <sub>IN</sub>
G <sub>Vc</sub>	—	—	—	Difference between G <sub>Vc+</sub> and G <sub>Vc-</sub>	—

## 〈DC/DC converter〉

Parameter	V <sub>ERR</sub>	IN	RL	Notes	Measurement point
V <sub>G</sub>	OFF	OFF	OFF		V <sub>G</sub>

## 〈Triangular wave generator〉

Parameter	V <sub>ERR</sub>	IN	RL	Notes	Measurement point
f <sub>OSC1</sub>	OFF	OFF	OFF	No clock input, CT = 220 pF, verify triangular waveform	Pin 15 waveform
f <sub>CLK11</sub>	OFF	OFF	OFF	Clock = 88 kHz, CT = 220 pF, verify clock synchronization of triangular wave	Pin 15 waveform
f <sub>CLK12</sub>	OFF	OFF	OFF	Clock = 176 kHz, CT = 220 pF, verify clock synchronization of triangular wave	Pin 15 waveform
f <sub>OSC2</sub>	OFF	OFF	OFF	No clock input, CT = 470 pF, verify triangular waveform	Pin 15 waveform
f <sub>CLK21</sub>	OFF	OFF	OFF	Clock = 44 kHz, CT = 470 pF, verify clock synchronization of triangular wave	Pin 15 waveform
f <sub>CLK22</sub>	OFF	OFF	OFF	Clock = 88 kHz, CT = 470 pF, verify clock synchronization of triangular wave	Pin 15 waveform

## 〈Control pin threshold〉

Parameter	V <sub>ERR</sub>	IN	RL	Notes	Measurement point
V <sub>MT</sub>	±0.5V	ON	ON	Verify: No output from V <sub>O1</sub> at V <sub>MT</sub> = 2.2 V	V <sub>O1</sub>
V <sub>PC</sub>	±0.5V	ON	ON	Verify: No output from V <sub>O1</sub> through V <sub>O4</sub> at V <sub>PC</sub> = 2.2 V	V <sub>O1~4</sub>
V <sub>ESP</sub>	OFF	OFF	OFF	Verify: V <sub>ESP</sub> = 2.2 V, pin 15 waveform is double the clock frequency	—

〈Operational amplifier〉

Parameter	VOP	OPIN	RLOP	Notes	Measurement point
I <sub>BIAS</sub>	OFF	2	OFF	R <sub>f</sub> =1MΩ, I <sub>BIAS</sub> = $\left  \frac{VR_f}{1M\Omega} \right $	V <sub>RF</sub>
V <sub>IOP</sub>	OFF	2	OFF	R <sub>f</sub> =0Ω	V <sub>IO</sub>
V <sub>OHOP</sub>	0V	2	OFF	R <sub>f</sub> =30kΩ	V <sub>OOP1</sub>
V <sub>OLOP</sub>	3V	2	OFF	R <sub>f</sub> =30kΩ	V <sub>OOP1</sub>
I <sub>SOU</sub>	OFF	2	GND	R <sub>f</sub> =0Ω, I <sub>SOU</sub> = $\left  \frac{V_{OOP}}{50\Omega} \right $	V <sub>OOP1</sub>
I <sub>SIN</sub>	OFF	2	Pre.V <sub>cc</sub>	R <sub>f</sub> =0Ω, I <sub>SIN</sub> = $\left  \frac{Pre.V_{cc}-V_{OOP}}{50\Omega} \right $	V <sub>OOP1</sub>
G <sub>vo</sub>	—	1	OFF	R <sub>f</sub> =OPEN, G <sub>vo</sub> =20log $\left  \frac{V_{OOP2}}{-75dBV} \right $	V <sub>OOP2</sub>
SR	—	1	OFF	R <sub>f</sub> = 30 kΩ, input pulse wave = 0.5 Vp-p	Pin 35 waveform

●Circuit operation

(1) PWM driver

This is an H bridge driver with four N-type FETs in the output stage. Output polarity and PWM duty vary in proportion to the input differential voltage between V<sub>c</sub>, and to the absolute value. The load is direct-PWM-driven by the square wave with this varying duty. This is a voltage feedback driver and so delivers a constant gain regardless of battery voltage variation.

(2) DC/DC convertor

The DC/DC converter that generates the voltage needed to drive the FETs of the output-stage H bridge. Pre.V<sub>cc</sub> is raised to 6.5V by attaching an inductance, Schottky barrier diode, and capacitor.

(3) Triangular wave generator

1) Free-running oscillation

The free-running oscillation frequency of the triangular waves can be set with an attached resistor (R<sub>t</sub>, between pin 16 and the ground) and capacitor (C<sub>t</sub>, between pin 15 and the ground). The triangular wave has an amplitude of 3/5 × Pre.V<sub>cc</sub> at the top and V<sub>F</sub> (approximately 0.7V) at the bottom. The ratio between rise time and fall time is 3: 1. Free-running frequency (f<sub>t</sub>) is determined with the following equation:

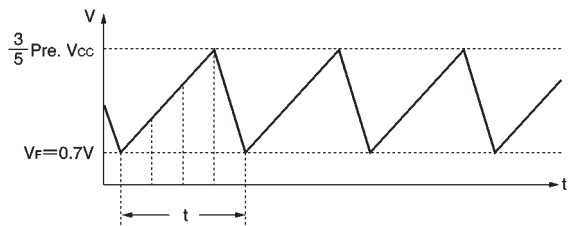

The triangular waveform during free-running oscillation

$$f_t = \frac{3}{4} \cdot \frac{1}{C_t \cdot R_t \left[ 1 - \frac{V_F}{\frac{3}{5} Pre.V_{cc}} \right]}$$

2) Clock synchronization

The triangular wave can be synchronized by inputting to the CLK pin (pin17) a pulse wave equal to 0–Pre.V<sub>CC</sub> (V<sub>p-p</sub>). The following precautions should be kept in mind:

- The amplitude of the triangular wave decreases as the clock frequency rises.

- The PWM driver is a voltage feedback driver, which should preclude any problems unless the setting is such that the triangular wave has an extremely small amplitude.
- As mentioned above, a capacitor and resistor are also required during clock synchronization.

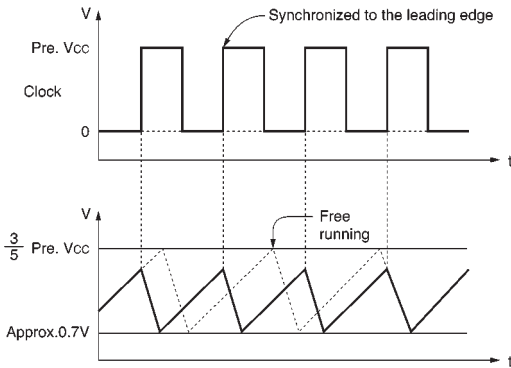

ESP = "L"

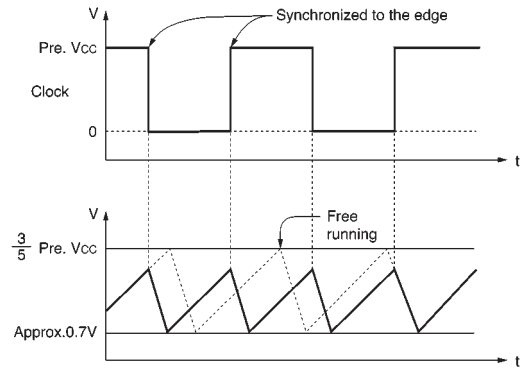

ESP = "H"

Clock synchronous triangle waveform

3) Using the ESP pin

1. To operate the PWM driver at 176.4kHz

Mode	Clock input frequency	ESP input voltage	Driver operating frequency
Normal	88.2kHz	'H'	176.4kHz
Double speed	176.4kHz	'L'	176.4kHz

2. To operate the PWM driver at 88.2kHz

Mode	Clock input frequency	ESP input voltage	Driver operating frequency
Normal	44.1kHz	'H'	88.2kHz
Double speed	88.2kHz	'L'	88.2kHz

● Application example

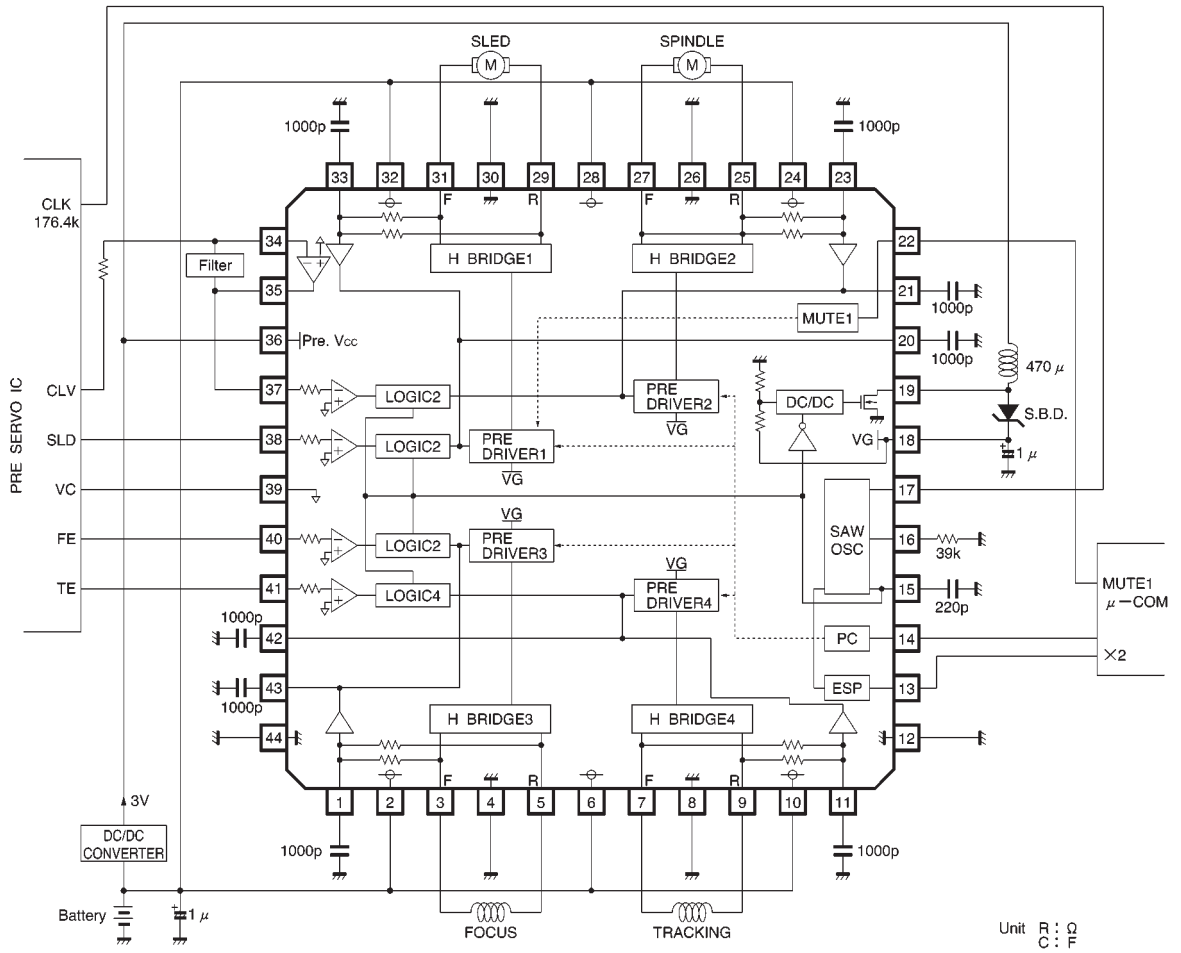

Fig. 2

● Operation notes

Attach a bypass capacitor (roughly 1 $\mu$ F) to the power supply, at the base of the IC.

● Electrical characteristic curves

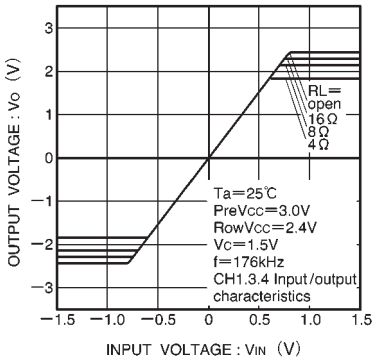

Fig. 3 Driver I/O characteristics (variable load)  
Channels 1, 3, 4

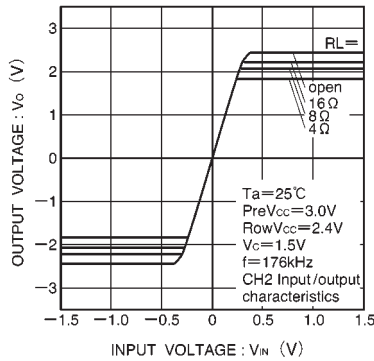

Fig. 4 Driver I/O characteristics (variable load)  
Channel 2

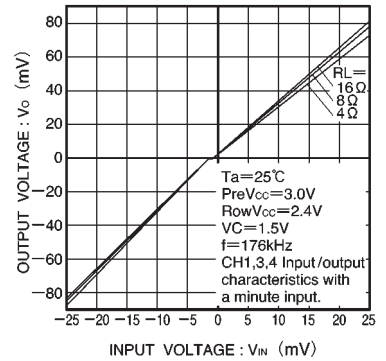

Fig. 5 Dead zone I/O characteristics  
Channels 1, 3, 4

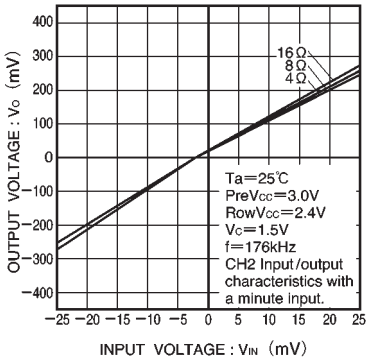

Fig. 6 Dead zone I/O characteristics  
Channel 2

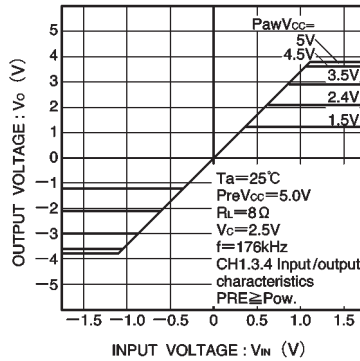

Fig. 7 Driver I/O characteristics (variable supply voltage)

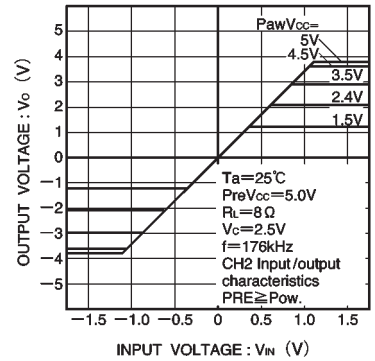

Fig. 8 Driver I/O characteristics (variable supply voltage)

● External dimensions (Units: mm)

