



Audio driver for cellular phones BH7823AFVM

● Description

BH7823AFVM is an audio driver IC developed for mobile audio appliances such as cellular phones. This driver has achieved low voltage driving and low power consumption. Audio signal can be generated from any various audio appliances. (This speaker can drive the load of 4, 8, and 12.) Achieve high output power supply by applying BTL. Suspend control can keep the circuit current at 0μA (Typ.) when it is not in use.

● Dimension (Units : mm)

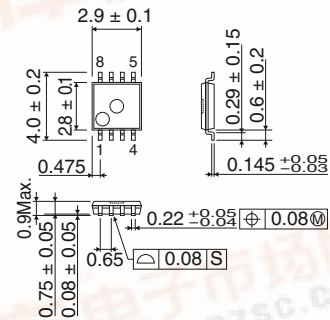

MSOP8

● Features

- 1) BTL monaural audio power amplifier
- 2) High power 500mW/8 /BTL output
- 3) Wide operating voltage range
- 4) For active/shutdown MODE
- 5) Built-in anti-pop circuit/thermal shutdown circuit
- 6) Perfect for cellular phones, palm PC, hand-held appliances

● Applications

Audio driver for cellular phones

● Absolute Maximum Ratings (Ta=25°C)

Parameter	Symbol	Limits	Unit
Applied voltage	VccMAX	6.0	V
Power dissipation	Pd	370 *	mW
Operating temperature range	Topr	-20 ~ +70	°C
Storage temperature range	Tstg	-55 ~ +125	°C

Derating : 3.5mW/°C for operation above Ta=25°C
PCB (70mmx70mm, t=1.6mm) glass epoxy mounting.



● Recommended Operating Conditions (Ta=25°C)

Parameter	Symbol	Min.	Typ.	Max.	Unit
Operating voltage range	V _{CCS}	2.8	–	5.5	V

This product is not designed for protection against radioactive rays.

● Electrical characteristics (Unless otherwise noted; Ta=25°C, V_{CC}=3.6V, f=1kHz, R_L=8)

Parameter	Symbol	Min.	Typ.	Max.	Unit	Conditions
Circuit current 1	I _{CC1}	–	3	7	mA	No signal Active MODE
Circuit current 2	I _{CC2}	–	0	2	μA	No signal Suspend MODE
Voltage gain 1	G _{V1}	9.5	11.5	13.5	dB	V _{IN} =-20dBV 1st OPAMP gain
Voltage gain 2	G _{V2}	-2.0	0	2.0	dB	V _{IN} =-20dBV 2nd OPAMP gain
Maximum output voltage	V _{OM}	4.8	6.8	–	dBV	DSTN=10% BTL 1
Output distortion rate	DSTN	–	0.2	1.0	%	V _{IN} =-20dBV SE 1
Output residual noise	V _{NO}	–	-94	-80	dBV	No signal, SE Active MODE 2
Suspend attenuation	G _S	–	-107	-80	dBV	V _{IN} =-20dBV BTL 2
BIAS set voltage	V _{BIAS}	1.6	1.8	2.0	V	2PIN DC voltage
Suspend hold voltage/ H	V _{SH}	V _{CC} /3+0.8	–	V _{CC}	V	Active MODE Hold voltage
Suspend hold voltage/ L	V _{SL}	0	–	0.5	V	Suspend MODE Hold voltage

1: 0.4~30kHz 2: DIN AUDIO

● Application Circuit

