

TLVH431, TLVH431A, TLVH431B TLVH432, TLVH432A, TLVH432B LOW-VOLTAGE ADJUSTABLE PRECISION SHUNT REGULATOR

SLVS555D – NOVEMBER 2004 – REVISED FEBRUARY 2005

- Low-Voltage Operation . . . Down to 1.24 V
- Reference Voltage Tolerances at 25°C
 - 0.5% for B Grade
 - 1% for A Grade
 - 1.5% for Standard Grade
- Adjustable Output Voltage, $V_O = V_{REF}$ to 18 V
- Wide Operating Cathode Current Range . . . 55 μ A to 80 mA
- 0.25- Ω Typical Output Impedance
- –40°C to 125°C Specifications
- TLVH432 Provides Alternative Pinouts for SOT-23-3 and SOT-89 Packages
- Ultra-Small SC-70 Package Offers 40% Smaller Footprint Than SOT-23-3

TLVH431
DBV (SOT23-5) PACKAGE
(TOP VIEW)

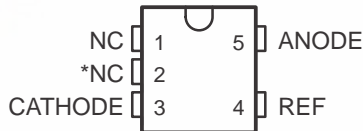

NC - No internal connection
* Pin 2 is connected internally to ANODE (die substrate). Pin 2 should be connected to ANODE or left floating.

TLVH431
DBZ (SOT23-3) PACKAGE
(TOP VIEW)

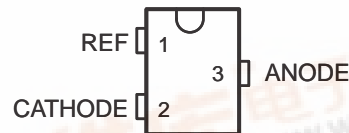

TLVH431
DCK (SC-70) PACKAGE
(TOP VIEW)

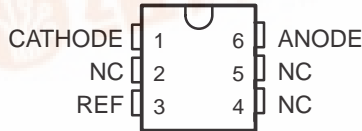

NC - No internal connection

TLVH431
LP (TO-92/TO-226) PACKAGE
(TOP VIEW)

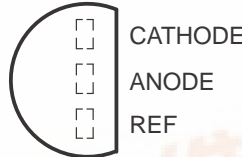

TLVH431
PK (SOT-89) PACKAGE
(TOP VIEW)

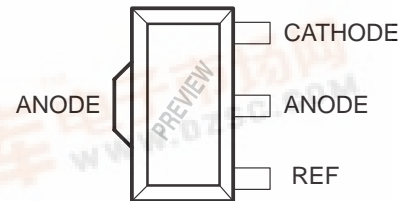

TLVH432
PK (SOT-89) PACKAGE
(TOP VIEW)

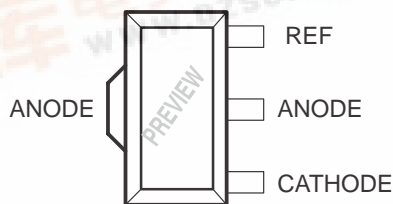

TLVH432
DBZ (SOT23-3) PACKAGE
(TOP VIEW)

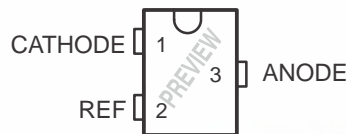

description/ordering information

The TLVH431 and TLVH432 are low-voltage 3-terminal adjustable voltage references with specified thermal stability over applicable industrial and commercial temperature ranges. Output voltage can be set to any value between V_{REF} (1.24 V) and 18 V with two external resistors (see Figure 2). These devices operate from a lower voltage (1.24 V) than the widely used TL431 and TL1431 shunt-regulator references.

Please be aware that an important notice concerning availability, standard warranty, and use in critical applications of Texas Instruments semiconductor products and disclaimers thereto appears at the end of this data sheet.



TLVH431, TLVH431A, TLVH431B
TLVH432, TLVH432A, TLVH432B
LOW-VOLTAGE ADJUSTABLE PRECISION SHUNT REGULATOR

SLVS555D – NOVEMBER 2004 – REVISED FEBRUARY 2005

description/ordering information (continued)

When used with an optocoupler, the TLVH431 and TLVH432 are ideal voltage references in isolated feedback circuits for 3-V to 3.3-V switching-mode power supplies. They have a typical output impedance of 0.25 Ω . Active output circuitry provides a very sharp turn-on characteristic, making the TLVH431 and TLVH432 excellent replacements for low-voltage Zener diodes in many applications, including on-board regulation and adjustable power supplies.

The TLVH432 is identical to the TLVH431, but is offered with different pinouts for the SOT23-3 and SOT-89 packages.

TLVH431, TLVH431A, TLVH431B
TLVH432, TLVH432A, TLVH432B
LOW-VOLTAGE ADJUSTABLE PRECISION SHUNT REGULATOR

SLVS555D – NOVEMBER 2004 – REVISED FEBRUARY 2005

ORDERING INFORMATION

T _J	V _{REF} TOLERANCE	PACKAGE†	ORDERABLE PART NUMBER	TOP-SIDE MARKING‡	
0°C to 70°C	0.5%	SC-70 (DCK)	Reel of 3000	TLVH431BCDCKR	YH_
			Reel of 250	TLVH431BCDCKT	
		SOT-23-5 (DBV)	Reel of 3000	TLVH431BCDBVR	Y3J_
			Reel of 250	TLVH431BCDBVT	PREVIEW
		SOT-23-3 (DBZ)	Reel of 3000	TLVH431BCDBZR	Y3J_
				TLVH432BCDBZR	
			Reel of 250	TLVH431BCDBZT	PREVIEW
				TLVH432BCDBZT	
		SOT-89 (PK)	Reel of 1000	TLVH431BCPK	PREVIEW
				TLVH432BCPK	
		TO-92 (LP)	Bulk of 1000	TLVH431BCLP	ZA431B
			Reel of 2000	TLVH431BCLPR	
	1%	SC-70 (DCK)	Reel of 3000	TLVH431ACDCKR	PREVIEW
			Reel of 250	TLVH431ACDCKT	
		SOT-23-5 (DBV)	Reel of 3000	TLVH431ACDBVR	PREVIEW
			Reel of 250	TLVH431ACDBVT	
		SOT-23-3 (DBZ)	Reel of 3000	TLVH431ACDBZR	PREVIEW
				TLVH432ACDBZR	
			Reel of 250	TLVH431ACDBZT	
				TLVH432ACDBZT	
		SOT-89 (PK)	Reel of 1000	TLVH431ACPK	PREVIEW
				TLVH432ACPK	
		TO-92 (LP)	Bulk of 1000	TLVH431ACL	PREVIEW
			Reel of 2000	TLVH431ACLPR	
	1.5%	SC-70 (DCK)	Reel of 3000	TLVH431CDCKR	PREVIEW
			Reel of 250	TLVH431CDCKT	
		SOT-23-5 (DBV)	Reel of 3000	TLVH431CDBVR	PREVIEW
			Reel of 250	TLVH431CDBVT	
		SOT-23-3 (DBZ)	Reel of 3000	TLVH431CDBZR	PREVIEW
				TLVH432CDBZR	
Reel of 250			TLVH431CDBZT		
			TLVH432CDBZT		
SOT-89 (PK)		Reel of 1000	TLVH431CPK	PREVIEW	
			TLVH432CPK		
TO-92 (LP)		Bulk of 1000	TLVH431CLP	PREVIEW	
		Reel of 2000	TLVH431CLPR		

† Package drawings, standard packing quantities, thermal data, symbolization, and PCB design guidelines are available at www.ti.com/sc/package.

‡ DBV/DBZ/DCK: The actual top-side marking has one additional character that designates the assembly/test site.

TLVH431, TLVH431A, TLVH431B
TLVH432, TLVH432A, TLVH432B
LOW-VOLTAGE ADJUSTABLE PRECISION SHUNT REGULATOR

SLVS555D – NOVEMBER 2004 – REVISED FEBRUARY 2005

ORDERING INFORMATION (continued)

T _J	V _{REF} TOLERANCE	PACKAGE†	ORDERABLE PART NUMBER	TOP-SIDE MARKING‡	
-40°C to 85°C	0.5%	SC-70 (DCK)	Reel of 3000	TLVH431BIDCKR	YJ_
			Reel of 250	TLVH431BIDCKT	
		SOT-23-5 (DBV)	Reel of 3000	TLVH431BIDBVR	Y3K_
			Reel of 250	TLVH431BIDBVT	PREVIEW
		SOT-23-3 (DBZ)	Reel of 3000	TLVH431BIDBZR	Y3K_
				TLVH432BIDBZR	PREVIEW
			Reel of 250	TLVH431BIDBZT	
		TLVH432BIDBZT			
		SOT-89 (PK)	Reel of 1000	TLVH431BIPK	PREVIEW
				TLVH432BIPK	
		TO-92 (LP)	Bulk of 1000	TLVH431BILP	ZB431B
			Reel of 2000	TLVH431BILPR	
	1%	SC-70 (DCK)	Reel of 3000	TLVH431AIDCKR	PREVIEW
			Reel of 250	TLVH431AIDCKT	
		SOT-23-5 (DBV)	Reel of 3000	TLVH431AIDBVR	PREVIEW
			Reel of 250	TLVH431AIDBVT	
		SOT-23-3 (DBZ)	Reel of 3000	TLVH431AIDBZR	PREVIEW
				TLVH432AIDBZR	
			Reel of 250	TLVH431AIDBZT	
		TLVH432AIDBZT			
		SOT-89 (PK)	Reel of 1000	TLVH431AQPK	PREVIEW
				TLVH432AQPK	
		TO-92 (LP)	Bulk of 1000	TLVH431AILP	PREVIEW
			Reel of 2000	TLVH431AILPR	
1.5%	SC-70 (DCK)	Reel of 3000	TLVH431IDCKR	PREVIEW	
		Reel of 250	TLVH431IDCKT		
	SOT-23-5 (DBV)	Reel of 3000	TLVH431IDBVR	PREVIEW	
		Reel of 250	TLVH431IDBVT		
	SOT-23-3 (DBZ)	Reel of 3000	TLVH431IDBZR	PREVIEW	
			TLVH432IDBZR		
		Reel of 250	TLVH431IDBZT		
	TLVH432IDBZT				
	SOT-89 (PK)	Reel of 1000	TLVH431IQPK	PREVIEW	
			TLVH432IQPK		
	TO-92 (LP)	Bulk of 1000	TLVH431ILP	PREVIEW	
		Reel of 2000	TLVH431ILPR		

† Package drawings, standard packing quantities, thermal data, symbolization, and PCB design guidelines are available at www.ti.com/sc/package.

‡ DBV/DBZ/DCK: The actual top-side marking has one additional character that designates the assembly/test site.

TLVH431, TLVH431A, TLVH431B
TLVH432, TLVH432A, TLVH432B
LOW-VOLTAGE ADJUSTABLE PRECISION SHUNT REGULATOR

SLVS555D – NOVEMBER 2004 – REVISED FEBRUARY 2005

ORDERING INFORMATION (continued)

T _J	V _{REF} TOLERANCE	PACKAGE†	ORDERABLE PART NUMBER	TOP-SIDE MARKING‡		
–40°C to 125°C	0.5%	SC-70 (DCK)	Reel of 3000	TLVH431BQDCKR	YK_	
			Reel of 250	TLVH431BQDCKT		
		SOT-23-5 (DBV)	Reel of 3000	TLVH431BQDBVR	Y3L_	
			Reel of 250	TLVH431BQDBVT	PREVIEW	
		SOT-23-3 (DBZ)	Reel of 3000	TLVH431BQDBZR	Y3L_	
				TLVH432BQDBZR	PREVIEW	
			Reel of 250	TLVH431BQDBZT		
				TLVH432BQDBZT		
		SOT-89 (PK)	Reel of 1000	TLVH431BQPK TLVH432BQPK	PREVIEW	
		TO-92 (LP)	Bulk of 1000	TLVH431BQLP	ZD431B	
			Reel of 2000	TLVH431BQLPR		
		1%	SC-70 (DCK)	Reel of 3000	TLVH431AQDCKR	PREVIEW
	Reel of 250			TLVH431AQDCKT		
	SOT-23-5 (DBV)		Reel of 3000	TLVH431AQDBVR	PREVIEW	
			Reel of 250	TLVH431AQDBVT		
	SOT-23-3 (DBZ)		Reel of 3000	TLVH431AQDBZR	PREVIEW	
				TLVH432AQDBZR		
			Reel of 250	TLVH431AQDBZT		
				TLVH432AQDBZT		
	SOT-89 (PK)		Reel of 1000	TLVH431AQPK TLVH432AQPK	PREVIEW	
	TO-92 (LP)		Bulk of 1000	TLVH431AQLP	PREVIEW	
			Reel of 2000	TLVH431AQLPR		
	1.5%		SC-70 (DCK)	Reel of 3000	TLVH431QDCKR	PREVIEW
		Reel of 250		TLVH431QDCKT		
		SOT-23-5 (DBV)	Reel of 3000	TLVH431QDBVR	PREVIEW	
			Reel of 250	TLVH431QDBVT		
		SOT-23-3 (DBZ)	Reel of 3000	TLVH431QDBZR	PREVIEW	
				TLVH432QDBZR		
			Reel of 250	TLVH431QDBZT		
				TLVH432QDBZT		
SOT-89 (PK)		Reel of 1000	TLVH431QPK TLVH432QPK	PREVIEW		
TO-92 (LP)		Bulk of 1000	TLVH431QLP	PREVIEW		
		Reel of 2000	TLVH431QLPR			

† Package drawings, standard packing quantities, thermal data, symbolization, and PCB design guidelines are available at www.ti.com/sc/package.

‡ DBV/DBZ/DCK: The actual top-side marking has one additional character that designates the assembly/test site.

TLVH431, TLVH431A, TLVH431B
TLVH432, TLVH432A, TLVH432B
LOW-VOLTAGE ADJUSTABLE PRECISION SHUNT REGULATOR
SLVS555D – NOVEMBER 2004 – REVISED FEBRUARY 2005

logic block diagram

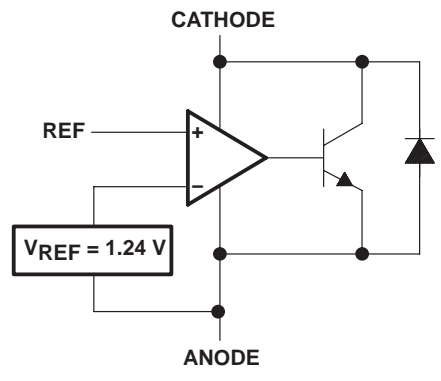

equivalent schematic

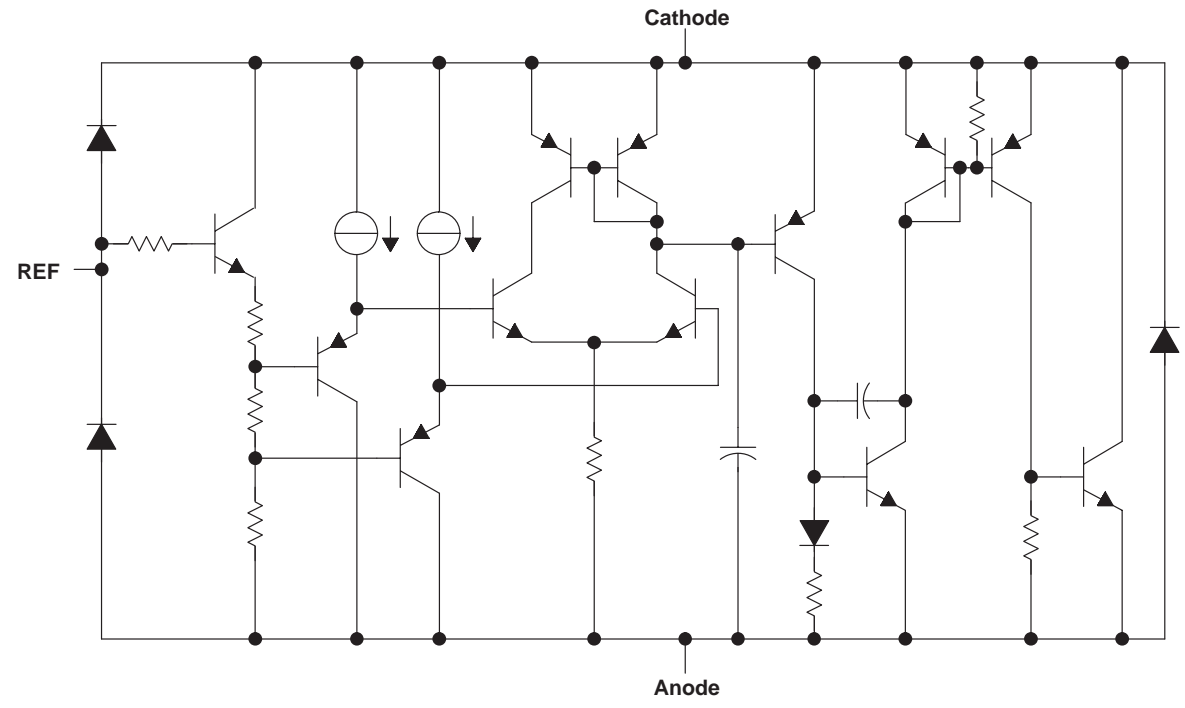

TLVH431, TLVH431A, TLVH431B
TLVH432, TLVH432A, TLVH432B
LOW-VOLTAGE ADJUSTABLE PRECISION SHUNT REGULATOR

SLVS555D – NOVEMBER 2004 – REVISED FEBRUARY 2005

absolute maximum ratings over operating free-air temperature range (unless otherwise noted)†

Cathode voltage, V_{KA} (see Note 1)	20 V
Cathode current range, I_K	–25 mA to 80 mA
Reference current range, I_{ref}	–0.05 mA to 3 mA
Package thermal impedance, θ_{JA} (see Notes 2 and 3):	
DBV package	206°C/W
DBZ package	206°C/W
DCK package	252°C/W
LP package	140°C/W
PK package	52°C/W
Operating virtual junction temperature	150°C
Storage temperature range, T_{stg}	–65°C to 150°C

† Stresses beyond those listed under “absolute maximum ratings” may cause permanent damage to the device. These are stress ratings only, and functional operation of the device at these or any other conditions beyond those indicated under “recommended operating conditions” is not implied. Exposure to absolute-maximum-rated conditions for extended periods may affect device reliability.

- NOTES:
1. Voltage values are with respect to the anode terminal, unless otherwise noted.
 2. Maximum power dissipation is a function of $T_J(max)$, θ_{JA} , and T_A . The maximum allowable power dissipation at any allowable ambient temperature is $P_D = (T_J(max) - T_A)/\theta_{JA}$. Operating at the absolute maximum T_J of 150°C can affect reliability.
 3. The package thermal impedance is calculated in accordance with JESD 51-7.

recommended operating conditions

		MIN	MAX	UNIT
V_{KA}	Cathode voltage	V_{REF}	18	V
I_K	Cathode current (continuous)	0.1	80	mA
T_A	Operating free-air temperature range	TLVH43X_C	0	70
		TLVH43X_I	–40	85
		TLVH43X_Q	–40	125

TLVH431, TLVH431A, TLVH431B TLVH432, TLVH432A, TLVH432B LOW-VOLTAGE ADJUSTABLE PRECISION SHUNT REGULATOR

SLVS555D – NOVEMBER 2004 – REVISED FEBRUARY 2005

TLVH431 electrical characteristics at 25°C free-air temperature (unless otherwise noted)

PARAMETER	TEST CONDITIONS	TLVH431, TLVH432			UNIT	
		MIN	TYP	MAX		
V _{REF} Reference voltage	V _{KA} = V _{REF} , I _K = 10 mA	T _A = 25°C	1.222	1.24	1.258	V
		T _A = full range (see Note 4 and Figure 1)	TLVH431C	1.21	1.27	
			TLVH431I	1.202	1.278	
			TLVH431Q	1.194	1.286	
V _{REF(dev)} V _{REF} deviation over full temperature range (see Note 5)	V _{KA} = V _{REF} , I _K = 10 mA (see Note 4 and Figure 1)	TLVH431C	4	12	mV	
		TLVH431I	6	20		
		TLVH431Q	11	31		
$\frac{\Delta V_{REF}}{\Delta V_{KA}}$ Ratio of V _{REF} change to cathode voltage change	I _K = 10 mA (see Figure 2)	V _{KA} = V _{REF} to 18 V	-1.5	-2.7	mV/V	
I _{ref} Reference terminal current	I _K = 10 mA, R1 = 10 kΩ, R2 = open (see Figure 2)		0.1	0.5	μA	
I _{ref(dev)} I _{ref} deviation over full temperature range (see Note 5)	I _K = 10 mA, R1 = 10 kΩ, R2 = open (see Note 4 and Figure 2)	TLVH431C	0.05	0.3	μA	
		TLVH431I	0.1	0.4		
		TLVH431Q	0.15	0.5		
I _{K(min)} Minimum cathode current for regulation	V _{KA} = V _{REF} (see Figure 1)		60	100	μA	
I _{K(off)} Off-state cathode current	V _{REF} = 0, V _{KA} = 18 V (see Figure 3)		0.02	0.1	μA	
z _{KA} Dynamic impedance (see Note 6)	V _{KA} = V _{REF} , f ≤ 1 kHz, I _K = 0.1 mA to 80 mA (see Figure 1)		0.25	0.4	Ω	

- NOTES: 4. Full temperature ranges are: -40°C to 125°C for TLVH431Q, -40°C to 85°C for TLVH431I, and 0°C to 70°C for the TLVH431C.
5. The deviation parameters V_{REF(dev)} and I_{ref(dev)} are defined as the differences between the maximum and minimum values obtained over the rated temperature range. The average full-range temperature coefficient of the reference input voltage, αV_{REF}, is defined as:

$$|\alpha V_{REF}| \left(\frac{\text{ppm}}{^\circ\text{C}} \right) = \frac{\left(\frac{V_{REF(\text{dev})}}{V_{REF}(T_A=25^\circ\text{C})} \right) \times 10^6}{\Delta T_A}$$

where ΔT_A is the rated operating free-air temperature range of the device.

αV_{REF} can be positive or negative, depending on whether minimum V_{REF} or maximum V_{REF}, respectively, occurs at the lower temperature.

6. The dynamic impedance is defined as: $|z_{ka}| = \frac{\Delta V_{KA}}{\Delta I_K}$

When the device is operating with two external resistors (see Figure 2), the total dynamic impedance of the circuit is defined as:

$$|z_{ka}| = \frac{\Delta V}{\Delta I} \approx |z_{ka}| \times \left(1 + \frac{R1}{R2} \right)$$

TLVH431, TLVH431A, TLVH431B
TLVH432, TLVH432A, TLVH432B
LOW-VOLTAGE ADJUSTABLE PRECISION SHUNT REGULATOR

SLVS555D – NOVEMBER 2004 – REVISED FEBRUARY 2005

TLVH431A electrical characteristics at 25°C free-air temperature (unless otherwise noted)

PARAMETER	TEST CONDITIONS	TLVH431A TLVH432A			UNIT	
		MIN	TYP	MAX		
V _{REF} Reference voltage	V _{KA} = V _{REF} , I _K = 10 mA	T _A = 25°C	1.228	1.24	1.252	V
		T _A = full range (see Note 4 and Figure 1)	TLVH431AC	1.221	1.259	
			TLVH431AI	1.215	1.265	
V _{REF(dev)} V _{REF} deviation over full temperature range (see Note 5)	V _{KA} = V _{REF} , I _K = 10 mA (see Note 4 and Figure 1)	TLVH431AC	4	12	mV	
		TLVH431AI	6	20		
		TLVH431AQ	11	31		
$\frac{\Delta V_{REF}}{\Delta V_{KA}}$ Ratio of V _{REF} change to cathode voltage change	I _K = 10 mA (see Figure 2)	V _{KA} = V _{REF} to 18 V	-1.5	-2.7	mV/V	
I _{ref} Reference terminal current	I _K = 10 mA, R1 = 10 kΩ, R2 = open (see Figure 2)		0.1	0.5	μA	
I _{ref(dev)} I _{ref} deviation over full temperature range (see Note 5)	I _K = 10 mA, R1 = 10 kΩ, R2 = open (see Note 4 and Figure 2)	TLVH431AC	0.05	0.3	μA	
		TLVH431AI	0.1	0.4		
		TLVH431AQ	0.15	0.5		
I _{K(min)} Minimum cathode current for regulation	V _{KA} = V _{REF} (see Figure 1)		60	100	μA	
I _{K(off)} Off-state cathode current	V _{REF} = 0, V _{KA} = 18 V (see Figure 3)		0.02	0.1	μA	
z _{KA} Dynamic impedance (see Note 6)	V _{KA} = V _{REF} , f ≤ 1 kHz, I _K = 0.1 mA to 80 mA (see Figure 1)		0.25	0.4	Ω	

- NOTES: 4. Full temperature ranges are: -40°C to 125°C for TLVH431AQ, -40°C to 85°C for TLVH431AI, and 0°C to 70°C for the TLVH431AC.
5. The deviation parameters V_{REF(dev)} and I_{ref(dev)} are defined as the differences between the maximum and minimum values obtained over the rated temperature range. The average full-range temperature coefficient of the reference input voltage, αV_{REF}, is defined as:

$$|\alpha V_{REF}| \left(\frac{\text{ppm}}{^\circ\text{C}} \right) = \frac{\left(\frac{V_{REF(dev)}}{V_{REF}(T_A = 25^\circ\text{C})} \right) \times 10^6}{\Delta T_A}$$

where ΔT_A is the rated operating free-air temperature range of the device.

αV_{REF} can be positive or negative, depending on whether minimum V_{REF} or maximum V_{REF}, respectively, occurs at the lower temperature.

6. The dynamic impedance is defined as: $|z_{ka}| = \frac{\Delta V_{KA}}{\Delta I_K}$

When the device is operating with two external resistors (see Figure 2), the total dynamic impedance of the circuit is defined as:

$$|z_{ka}| = \frac{\Delta V}{\Delta I} \approx |z_{ka}| \times \left(1 + \frac{R1}{R2} \right)$$

TLVH431, TLVH431A, TLVH431B TLVH432, TLVH432A, TLVH432B LOW-VOLTAGE ADJUSTABLE PRECISION SHUNT REGULATOR

SLVS555D – NOVEMBER 2004 – REVISED FEBRUARY 2005

TLVH431B electrical characteristics at 25°C free-air temperature (unless otherwise noted)

PARAMETER	TEST CONDITIONS	TLVH431B TLVH432B			UNIT	
		MIN	TYP	MAX		
V _{REF} Reference voltage	V _{KA} = V _{REF} , I _K = 10 mA	T _A = 25°C	1.234	1.24	1.246	V
		T _A = full range (see Note 4 and Figure 1)	TLVH431BC	1.227	1.253	
			TLVH431BI	1.224	1.259	
V _{REF(dev)} V _{REF} deviation over full temperature range (see Note 5)	V _{KA} = V _{REF} , I _K = 10 mA (see Note 4 and Figure 1)	TLVH431BC	4	12	mV	
		TLVH431BI	6	20		
		TLVH431BQ	11	31		
$\frac{\Delta V_{REF}}{\Delta V_{KA}}$ Ratio of V _{REF} change to cathode voltage change	I _K = 10 mA (see Figure 2)	V _{KA} = V _{REF} to 18 V	-1.5	-2.7	mV/V	
I _{ref} Reference terminal current	I _K = 10 mA, R1 = 10 kΩ (see Figure 2)		0.1	0.5	μA	
I _{ref(dev)} I _{ref} deviation over full temperature range (see Note 5)	I _K = 10 mA, R1 = 10 kΩ, R2 = open (see Note 4 and Figure 2)	TLVH431BC	0.05	0.3	μA	
		TLVH431BI	0.1	0.4		
		TLVH431BQ	0.15	0.5		
I _{K(min)} Minimum cathode current for regulation	V _{KA} = V _{REF} (see Figure 1)		60	100	μA	
I _{K(off)} Off-state cathode current	V _{REF} = 0, V _{KA} = 18 V (see Figure 3)		0.02	0.1	μA	
z _{KA} Dynamic impedance (see Note 6)	V _{KA} = V _{REF} , f ≤ 1 kHz, I _K = 0.1 mA to 80 mA (see Figure 1)		0.25	0.4	Ω	

- NOTES: 4. Full temperature ranges are: -40°C to 125°C for TLVH431BQ, -40°C to 85°C for TLVH431BI, and 0°C to 70°C for the TLVH431BC.
5. The deviation parameters V_{REF(dev)} and I_{ref(dev)} are defined as the differences between the maximum and minimum values obtained over the rated temperature range. The average full-range temperature coefficient of the reference input voltage, αV_{REF}, is defined as:

$$|\alpha V_{REF}| \left(\frac{\text{ppm}}{^\circ\text{C}} \right) = \frac{\left(\frac{V_{REF(dev)}}{V_{REF}(T_A=25^\circ\text{C})} \right) \times 10^6}{\Delta T_A}$$

where ΔT_A is the rated operating free-air temperature range of the device.

αV_{REF} can be positive or negative, depending on whether minimum V_{REF} or maximum V_{REF}, respectively, occurs at the lower temperature.

6. The dynamic impedance is defined as: $|z_{ka}| = \frac{\Delta V_{KA}}{\Delta I_K}$

When the device is operating with two external resistors (see Figure 2), the total dynamic impedance of the circuit is defined as:

$$|z_{ka}| = \frac{\Delta V}{\Delta I} \approx |z_{ka}| \times \left(1 + \frac{R1}{R2} \right)$$

TLVH431, TLVH431A, TLVH431B
 TLVH432, TLVH432A, TLVH432B
LOW-VOLTAGE ADJUSTABLE PRECISION SHUNT REGULATOR
 SLVS555D – NOVEMBER 2004 – REVISED FEBRUARY 2005

PARAMETER MEASUREMENT INFORMATION

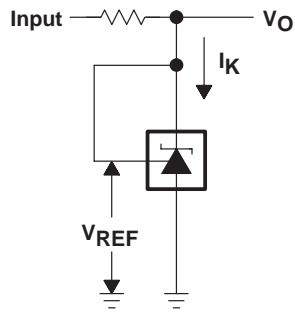

Figure 1. Test Circuit for $V_{KA} = V_{REF}$,
 $V_O = V_{KA} = V_{REF}$

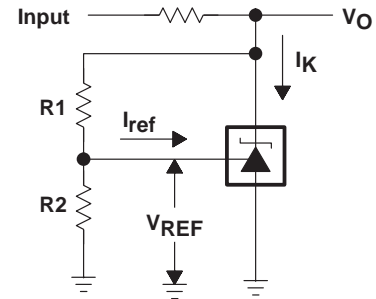

Figure 2. Test Circuit for $V_{KA} > V_{REF}$,
 $V_O = V_{KA} = V_{REF} \times (1 + R1/R2) + I_{ref} \times R1$

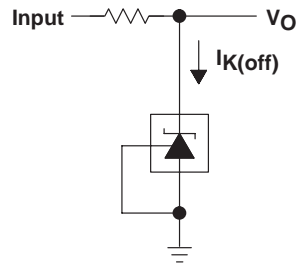

Figure 3. Test Circuit for $I_{K(off)}$

TLVH431, TLVH431A, TLVH431B
TLVH432, TLVH432A, TLVH432B
LOW-VOLTAGE ADJUSTABLE PRECISION SHUNT REGULATOR
 SLVS555D – NOVEMBER 2004 – REVISED FEBRUARY 2005

PARAMETER MEASUREMENT INFORMATION

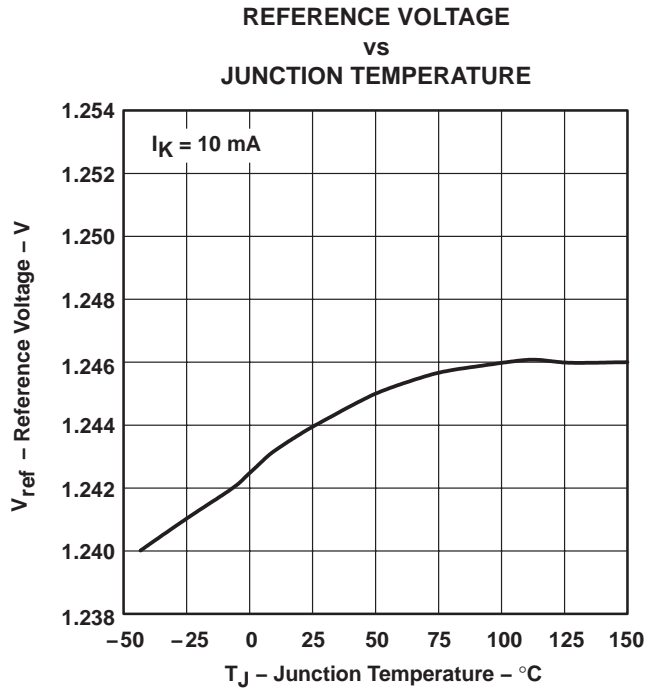

Figure 4

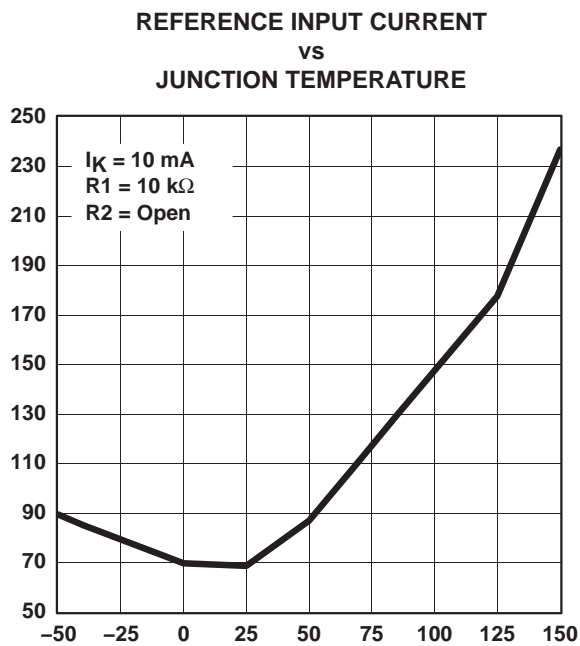

Figure 5

TLVH431, TLVH431A, TLVH431B
TLVH432, TLVH432A, TLVH432B
LOW-VOLTAGE ADJUSTABLE PRECISION SHUNT REGULATOR
SLVS555D – NOVEMBER 2004 – REVISED FEBRUARY 2005

PARAMETER MEASUREMENT INFORMATION†

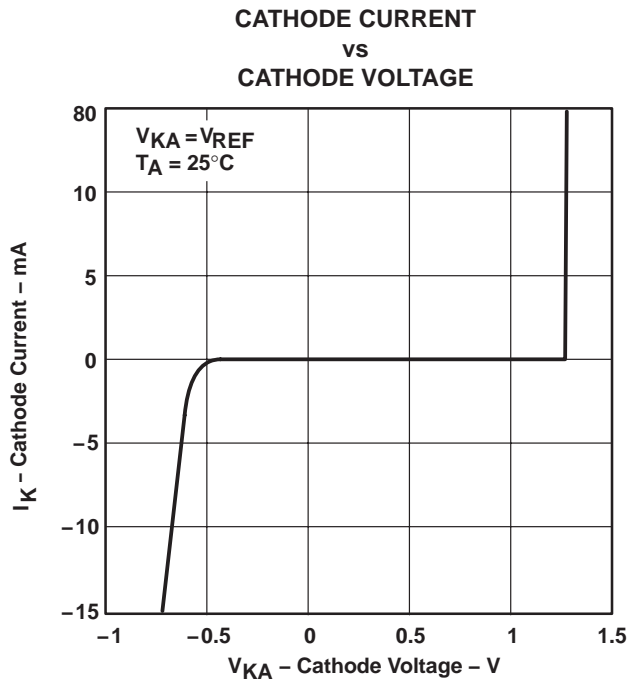

Figure 6

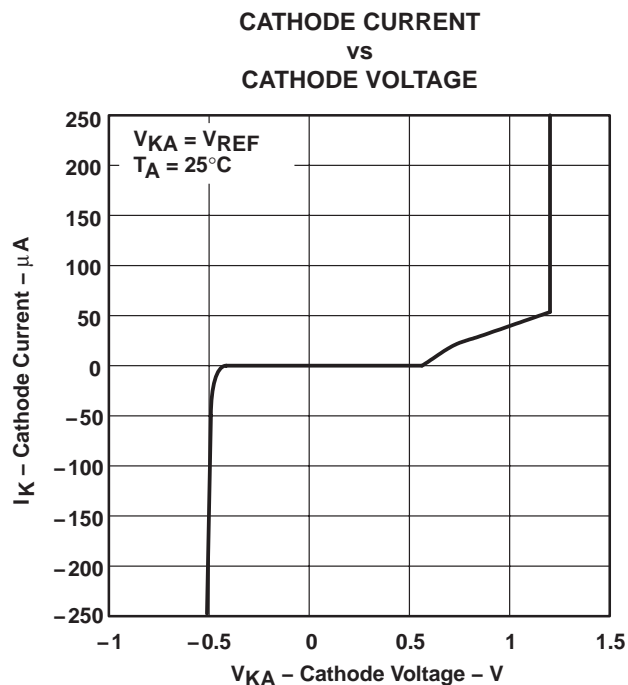

Figure 7

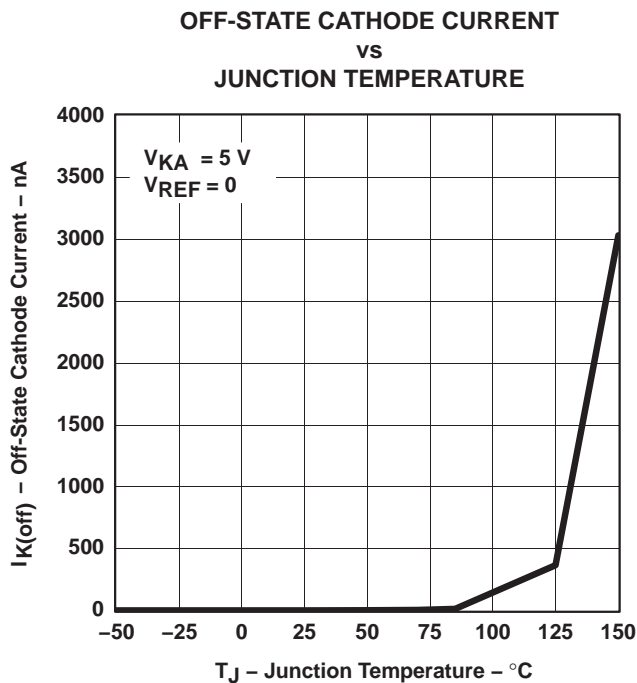

Figure 8

TLVH431, TLVH431A, TLVH431B
TLVH432, TLVH432A, TLVH432B
LOW-VOLTAGE ADJUSTABLE PRECISION SHUNT REGULATOR
 SLVS555D – NOVEMBER 2004 – REVISED FEBRUARY 2005

PARAMETER MEASUREMENT INFORMATION†

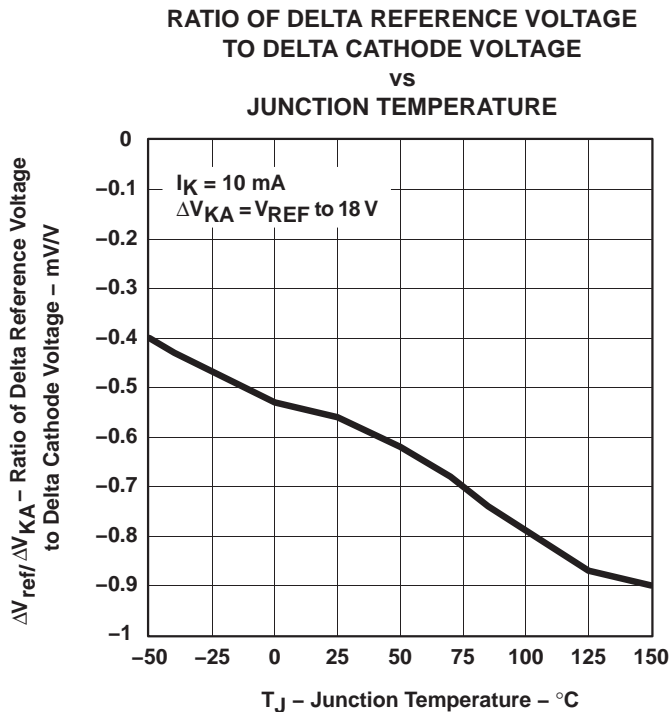
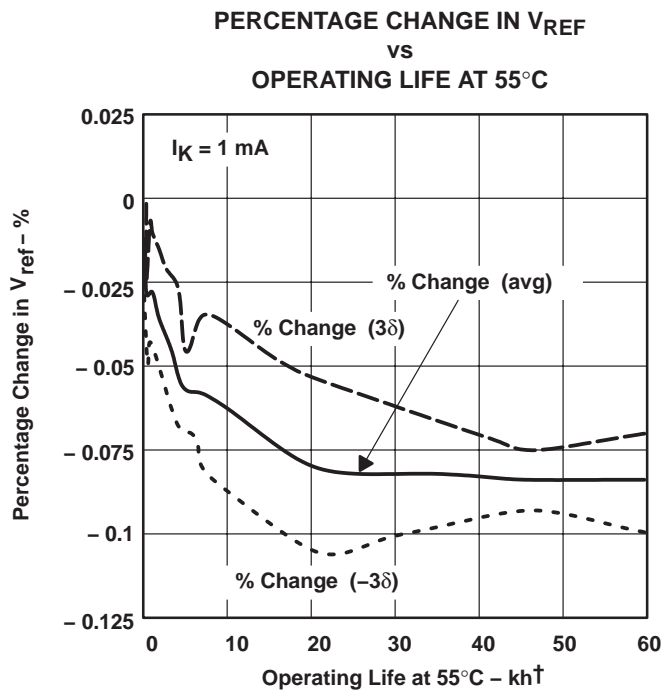

Figure 9



† Extrapolated from life-test data taken at 125°C; the activation energy assumed is 0.7 eV.

Figure 10

† Operation of the device at these or any other conditions beyond those indicated under “recommended operating conditions” is not implied.

TLVH431, TLVH431A, TLVH431B
TLVH432, TLVH432A, TLVH432B
LOW-VOLTAGE ADJUSTABLE PRECISION SHUNT REGULATOR
SLVS555D – NOVEMBER 2004 – REVISED FEBRUARY 2005

PARAMETER MEASUREMENT INFORMATION

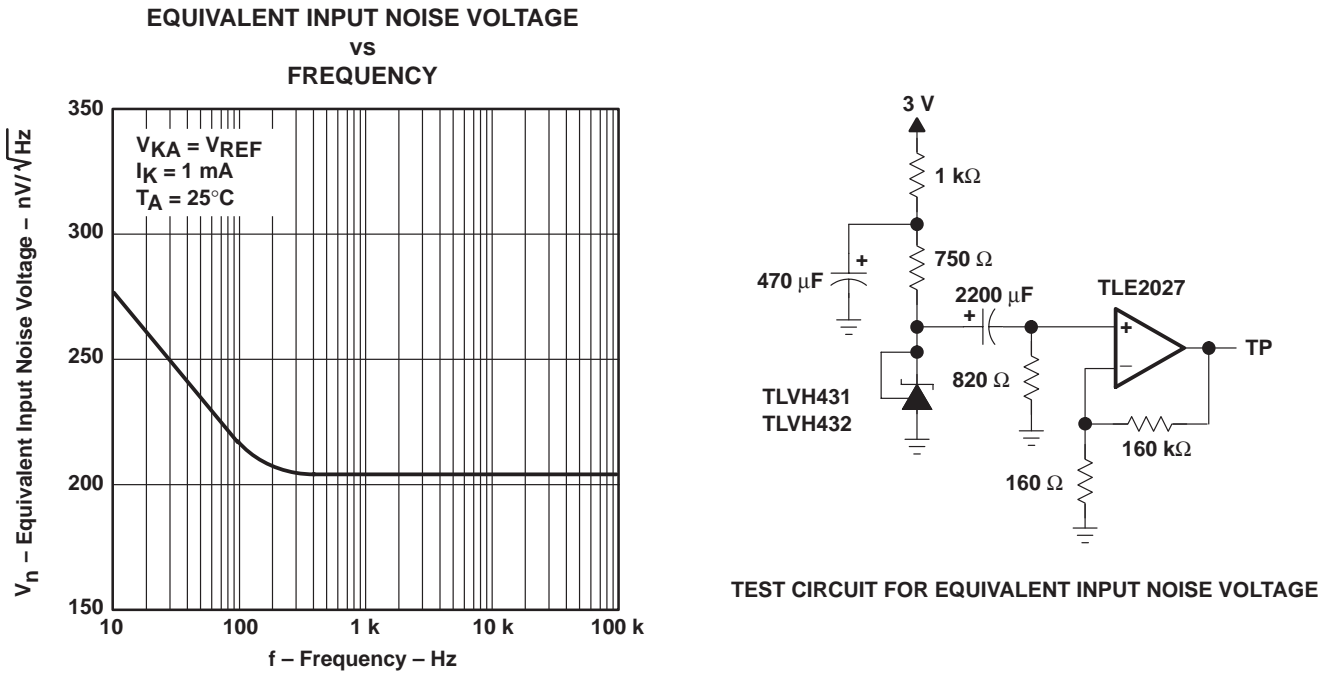

Figure 11

TLVH431, TLVH431A, TLVH431B
TLVH432, TLVH432A, TLVH432B
LOW-VOLTAGE ADJUSTABLE PRECISION SHUNT REGULATOR

SLVS555D – NOVEMBER 2004 – REVISED FEBRUARY 2005

PARAMETER MEASUREMENT INFORMATION

**EQUIVALENT INPUT NOISE VOLTAGE
OVER A 10-SECOND PERIOD**

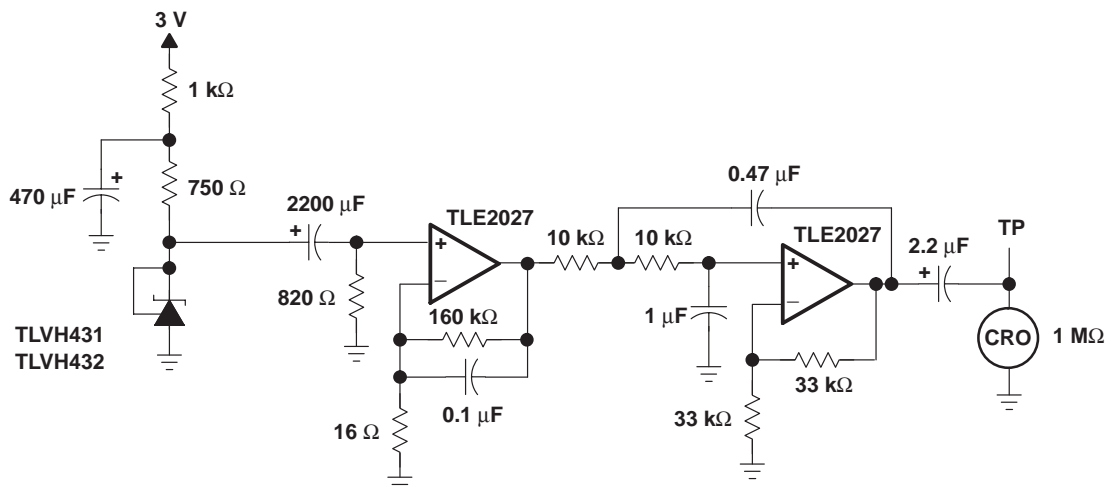
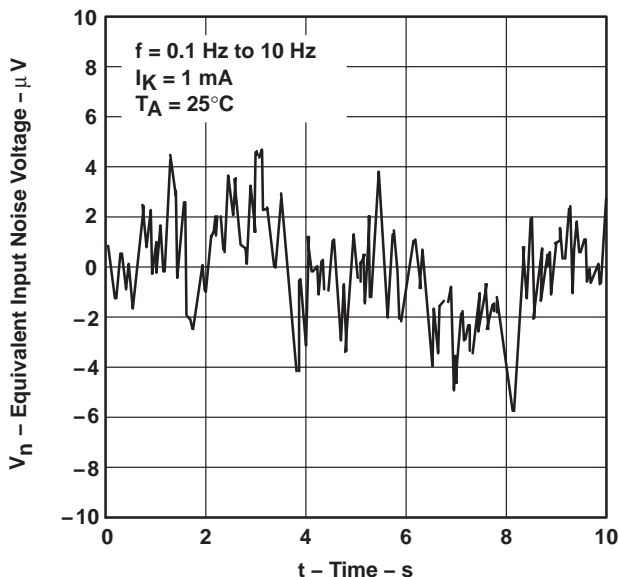

TEST CIRCUIT FOR 0.1-Hz TO 10-Hz EQUIVALENT NOISE VOLTAGE

Figure 12

TLVH431, TLVH431A, TLVH431B
 TLVH432, TLVH432A, TLVH432B
LOW-VOLTAGE ADJUSTABLE PRECISION SHUNT REGULATOR
 SLVS555D – NOVEMBER 2004 – REVISED FEBRUARY 2005

PARAMETER MEASUREMENT INFORMATION

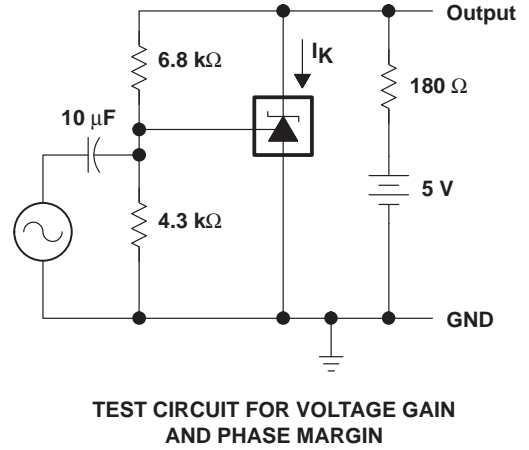
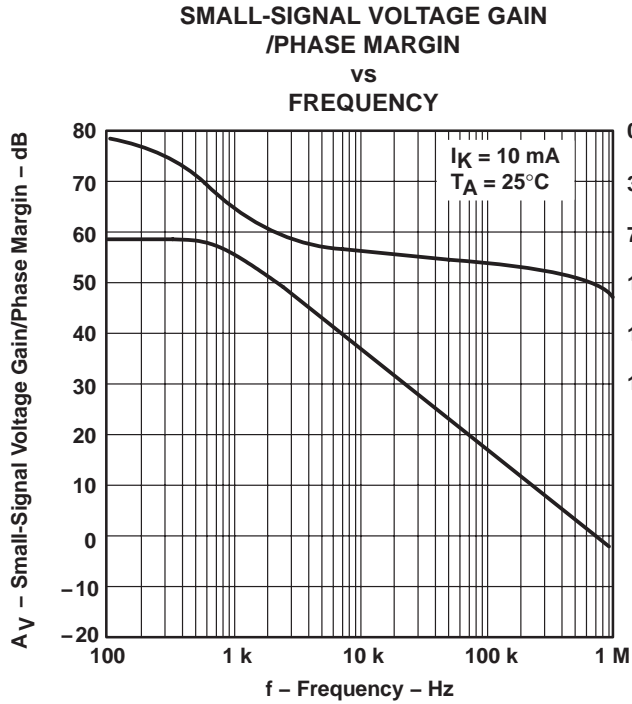

Figure 13

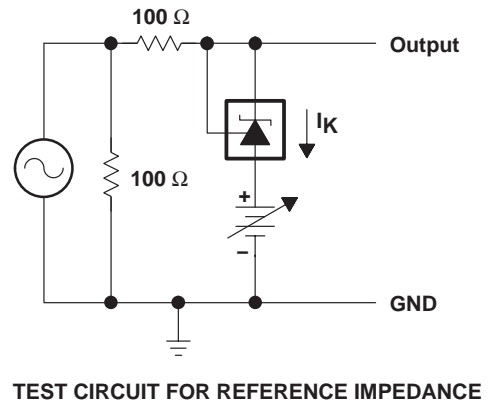
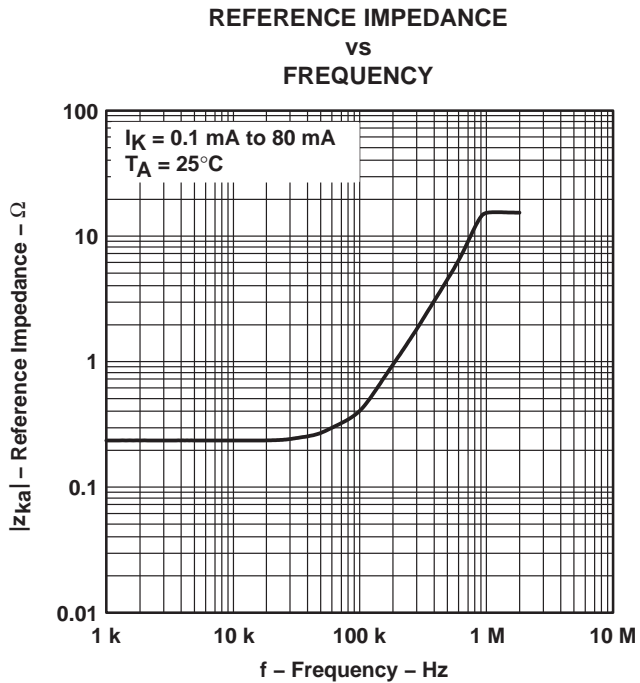

Figure 14

TLVH431, TLVH431A, TLVH431B
TLVH432, TLVH432A, TLVH432B
LOW-VOLTAGE ADJUSTABLE PRECISION SHUNT REGULATOR
 SLVS555D – NOVEMBER 2004 – REVISED FEBRUARY 2005

PARAMETER MEASUREMENT INFORMATION

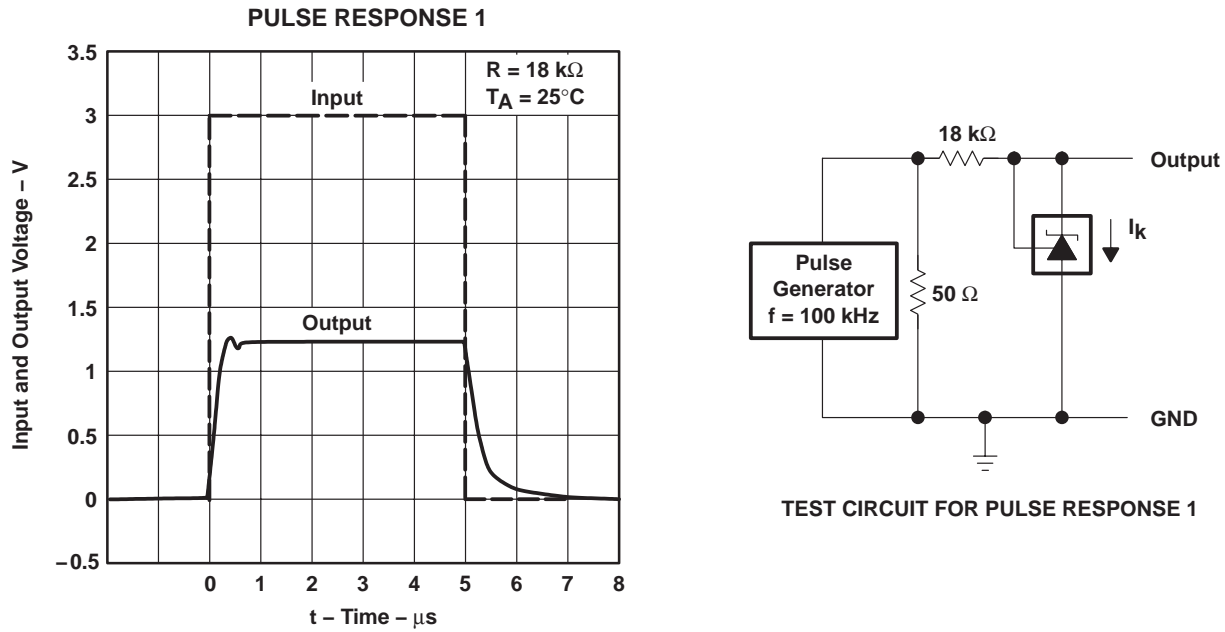

Figure 15

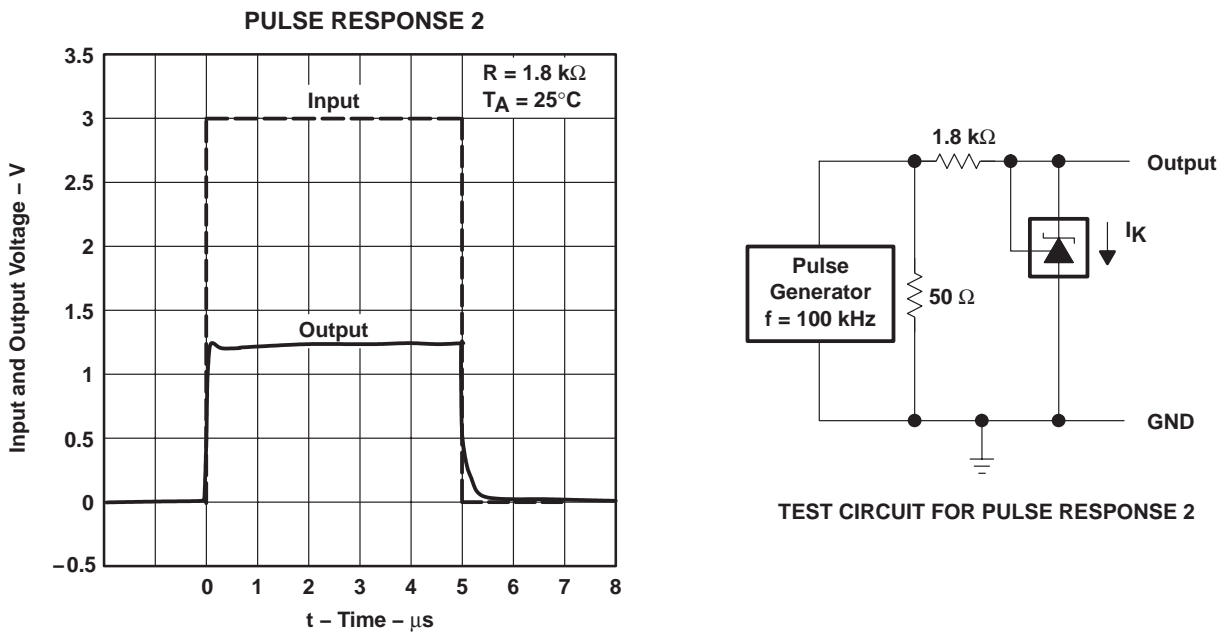
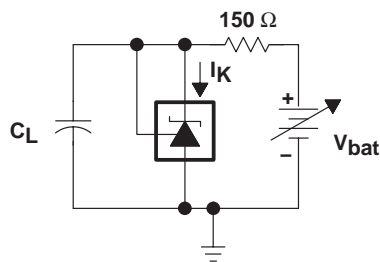
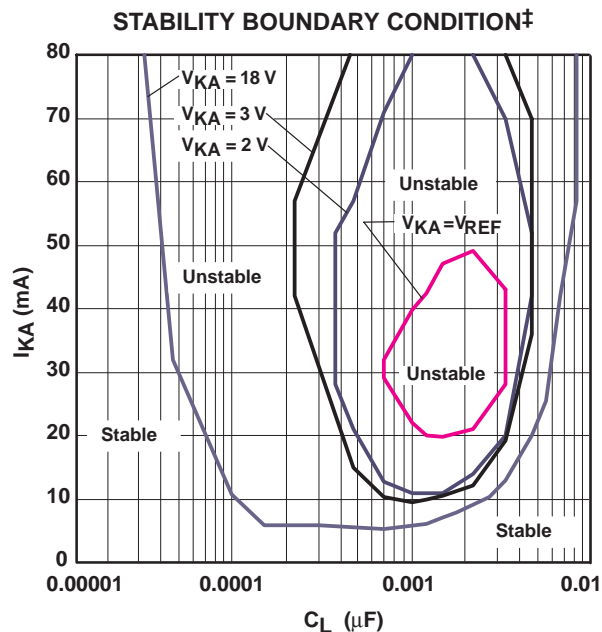

Figure 16

TLVH431, TLVH431A, TLVH431B
 TLVH432, TLVH432A, TLVH432B
LOW-VOLTAGE ADJUSTABLE PRECISION SHUNT REGULATOR
 SLVS555D – NOVEMBER 2004 – REVISED FEBRUARY 2005

PARAMETER MEASUREMENT INFORMATION†



TEST CIRCUIT FOR $V_{KA} = V_{REF}$

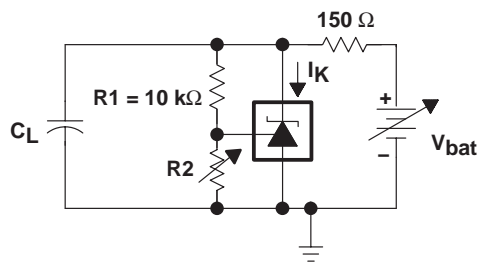

TEST CIRCUIT FOR $V_{KA} = 2\ \text{V}, 3\ \text{V}$

† Operation of the device at these or any other conditions beyond those indicated under "recommended operating conditions" is not implied.

‡ The areas enclosed by the curves represent conditions that may cause the device to oscillate. For $V_{KA} = 2\text{-V}, 3\text{-V}$, and 18-V curves, R_2 and V_{bat} were adjusted to establish the initial V_{KA} and I_K conditions with $C_L = 0$. V_{bat} and C_L then were adjusted to determine the ranges of stability.

Figure 17

TLVH431, TLVH431A, TLVH431B
TLVH432, TLVH432A, TLVH432B
LOW-VOLTAGE ADJUSTABLE PRECISION SHUNT REGULATOR
 SLVS555D – NOVEMBER 2004 – REVISED FEBRUARY 2005

APPLICATION INFORMATION

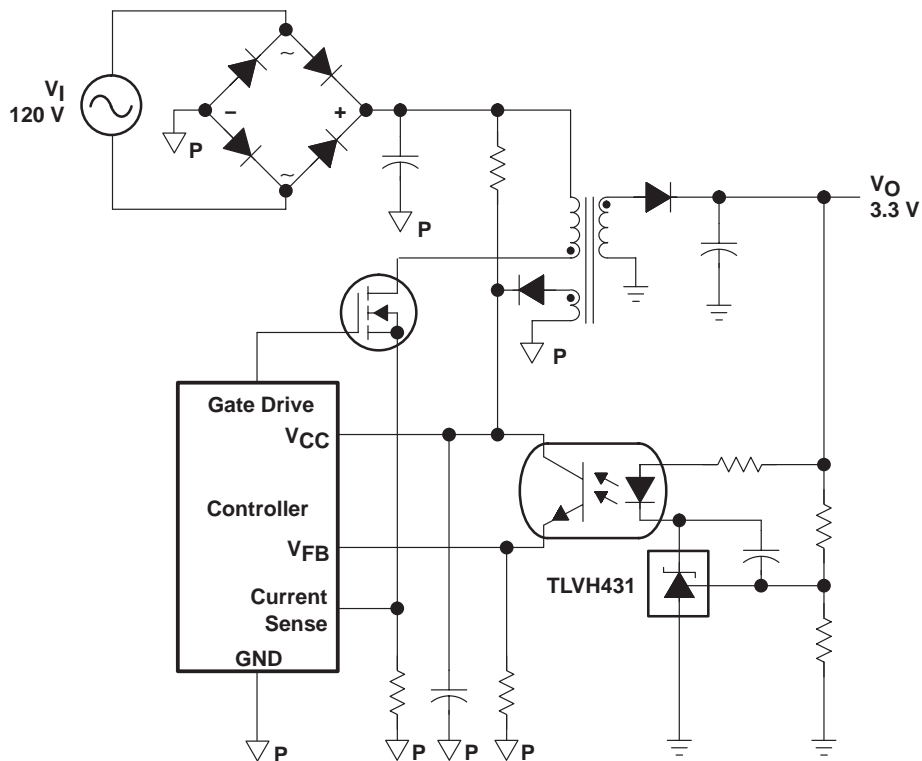

Figure 18. Flyback With Isolation Using TLVH431 and TLVH432 as Voltage Reference and Error Amplifier

Figure 18 shows the TLVH431 used in a 3.3-V isolated flyback supply. Output voltage V_O can be as low as reference voltage V_{REF} (1.24 V). The output of the regulator plus the forward voltage drop of the optocoupler LED ($1.24 + 1.4 = 2.64$ V) determine the minimum voltage that can be regulated in an isolated supply configuration. Regulated voltage as low as 2.7 Vdc is possible in the topology shown in Figure 18.

PACKAGING INFORMATION

Orderable Device	Status ⁽¹⁾	Package Type	Package Drawing	Pins	Package Qty	Eco Plan ⁽²⁾	Lead/Ball Finish	MSL Peak Temp ⁽³⁾
TLVH431ACDBVR	PREVIEW	SOT-23	DBV	5	3000	TBD	Call TI	Call TI
TLVH431ACDBVT	PREVIEW	SOT-23	DBV	5	250	TBD	Call TI	Call TI
TLVH431ACDBZR	PREVIEW	SOT-23	DBZ	3	3000	TBD	Call TI	Call TI
TLVH431ACDBZT	PREVIEW	SOT-23	DBZ	3	250	TBD	Call TI	Call TI
TLVH431ACDCKR	PREVIEW	SC70	DCK	6	3000	TBD	Call TI	Call TI
TLVH431ACDCKT	PREVIEW	SC70	DCK	6	250	TBD	Call TI	Call TI
TLVH431ACLCP	PREVIEW	TO-92	LP	3	1000	TBD	Call TI	Call TI
TLVH431ACLPR	PREVIEW	TO-92	LP	3	2000	TBD	Call TI	Call TI
TLVH431ACPK	PREVIEW	SOT-89	PK	3	1000	TBD	Call TI	Call TI
TLVH431AIDBVR	PREVIEW	SOT-23	DBV	5	3000	TBD	Call TI	Call TI
TLVH431AIDBVT	PREVIEW	SOT-23	DBV	5	250	TBD	Call TI	Call TI
TLVH431AIDBZR	PREVIEW	SOT-23	DBZ	3	3000	TBD	Call TI	Call TI
TLVH431AIDBZT	PREVIEW	SOT-23	DBZ	3	250	TBD	Call TI	Call TI
TLVH431AIDCKR	PREVIEW	SC70	DCK	6	3000	TBD	Call TI	Call TI
TLVH431AILP	PREVIEW	TO-92	LP	3	1000	TBD	Call TI	Call TI
TLVH431AILPR	PREVIEW	TO-92	LP	3	2000	TBD	Call TI	Call TI
TLVH431AIPK	PREVIEW	SOT-89	PK	3	1000	TBD	Call TI	Call TI
TLVH431AQDBVR	PREVIEW	SOT-23	DBV	5	3000	TBD	Call TI	Call TI
TLVH431AQDBVT	PREVIEW	SOT-23	DBV	5	250	TBD	Call TI	Call TI
TLVH431AQDBZR	PREVIEW	SOT-23	DBZ	3	3000	TBD	Call TI	Call TI
TLVH431AQDBZT	PREVIEW	SOT-23	DBZ	3	250	TBD	Call TI	Call TI
TLVH431AQDCKR	PREVIEW	SC70	DCK	6	3000	TBD	Call TI	Call TI
TLVH431AQDCKT	PREVIEW	SC70	DCK	6	250	TBD	Call TI	Call TI
TLVH431AQLP	PREVIEW	TO-92	LP	3	1000	TBD	Call TI	Call TI
TLVH431AQLPR	PREVIEW	TO-92	LP	3	2000	TBD	Call TI	Call TI
TLVH431AQP	PREVIEW	SOT-89	PK	3	1000	TBD	Call TI	Call TI
TLVH431BCDBVR	ACTIVE	SOT-23	DBV	5	3000	Green (RoHS & no Sb/Br)	CU NIPDAU	Level-1-260C-UNLIM
TLVH431BCDBVT	ACTIVE	SOT-23	DBV	5	250	Green (RoHS & no Sb/Br)	CU NIPDAU	Level-1-260C-UNLIM
TLVH431BCDBZR	ACTIVE	SOT-23	DBZ	3	3000	Green (RoHS & no Sb/Br)	CU NIPDAU	Level-1-260C-UNLIM
TLVH431BCDBZT	ACTIVE	SOT-23	DBZ	3	250	Green (RoHS & no Sb/Br)	CU NIPDAU	Level-1-260C-UNLIM
TLVH431BCDCKR	ACTIVE	SC70	DCK	6	3000	Green (RoHS & no Sb/Br)	CU NIPDAU	Level-1-260C-UNLIM
TLVH431BCDCKT	ACTIVE	SC70	DCK	6	250	Green (RoHS & no Sb/Br)	CU NIPDAU	Level-1-260C-UNLIM
TLVH431BCLP	ACTIVE	TO-92	LP	3	1000	TBD	CU SNPB	Level-NC-NC-NC
TLVH431BCLPR	ACTIVE	TO-92	LP	3	2000	TBD	CU SNPB	Level-NC-NC-NC
TLVH431BIDBVR	ACTIVE	SOT-23	DBV	5	3000	Green (RoHS & no Sb/Br)	CU NIPDAU	Level-1-260C-UNLIM
TLVH431BIDBVT	ACTIVE	SOT-23	DBV	5	250	Green (RoHS & no Sb/Br)	CU NIPDAU	Level-1-260C-UNLIM

Orderable Device	Status ⁽¹⁾	Package Type	Package Drawing	Pins	Package Qty	Eco Plan ⁽²⁾	Lead/Ball Finish	MSL Peak Temp ⁽³⁾
TLVH431BIDBZR	PREVIEW	SOT-23	DBZ	3		Green (RoHS & no Sb/Br)	CU NIPDAU	Level-1-260C-UNLIM
TLVH431BIDBZT	ACTIVE	SOT-23	DBZ	3	250	Green (RoHS & no Sb/Br)	CU NIPDAU	Level-1-260C-UNLIM
TLVH431BIDCKR	ACTIVE	SC70	DCK	6	3000	Green (RoHS & no Sb/Br)	CU NIPDAU	Level-1-260C-UNLIM
TLVH431BIDCKT	ACTIVE	SC70	DCK	6	250	Green (RoHS & no Sb/Br)	CU NIPDAU	Level-1-260C-UNLIM
TLVH431BILP	ACTIVE	TO-92	LP	3	1000	TBD	CU SNPB	Level-NC-NC-NC
TLVH431BILPR	ACTIVE	TO-92	LP	3	2000	TBD	CU SNPB	Level-NC-NC-NC
TLVH431BQDBVR	ACTIVE	SOT-23	DBV	5	3000	Green (RoHS & no Sb/Br)	CU NIPDAU	Level-1-260C-UNLIM
TLVH431BQDBVT	ACTIVE	SOT-23	DBV	5	250	Green (RoHS & no Sb/Br)	CU NIPDAU	Level-1-260C-UNLIM
TLVH431BQDBZR	ACTIVE	SOT-23	DBZ	3	3000	Green (RoHS & no Sb/Br)	CU NIPDAU	Level-1-260C-UNLIM
TLVH431BQDBZT	ACTIVE	SOT-23	DBZ	3	250	Green (RoHS & no Sb/Br)	CU NIPDAU	Level-1-260C-UNLIM
TLVH431BQDCKR	ACTIVE	SC70	DCK	6	3000	Green (RoHS & no Sb/Br)	CU NIPDAU	Level-1-260C-UNLIM
TLVH431BQDCKT	ACTIVE	SC70	DCK	6	250	Green (RoHS & no Sb/Br)	CU NIPDAU	Level-1-260C-UNLIM
TLVH431BQLP	ACTIVE	TO-92	LP	3	1000	TBD	CU SNPB	Level-NC-NC-NC
TLVH431BQLPR	ACTIVE	TO-92	LP	3	2000	TBD	CU SNPB	Level-NC-NC-NC
TLVH431CDBVR	PREVIEW	SOT-23	DBV	5	3000	TBD	Call TI	Call TI
TLVH431CDBVT	PREVIEW	SOT-23	DBV	5	250	TBD	Call TI	Call TI
TLVH431CDBZR	PREVIEW	SOT-23	DBZ	3	3000	TBD	Call TI	Call TI
TLVH431CDBZT	PREVIEW	SOT-23	DBZ	3	250	TBD	Call TI	Call TI
TLVH431CDCKR	PREVIEW	SC70	DCK	6	3000	TBD	Call TI	Call TI
TLVH431CDCKT	PREVIEW	SC70	DCK	6	250	TBD	Call TI	Call TI
TLVH431CLP	PREVIEW	TO-92	LP	3	1000	TBD	Call TI	Call TI
TLVH431CLPR	PREVIEW	TO-92	LP	3	2000	TBD	Call TI	Call TI
TLVH431CPK	PREVIEW	SOT-89	PK	3	1000	TBD	Call TI	Call TI
TLVH431BQDBZR	PREVIEW	SOT-23	DBZ	3		TBD	Call TI	Call TI
TLVH431IDBVR	PREVIEW	SOT-23	DBV	5	3000	TBD	Call TI	Call TI
TLVH431IDBVT	PREVIEW	SOT-23	DBV	5	250	TBD	Call TI	Call TI
TLVH431IDBZR	PREVIEW	SOT-23	DBZ	3	3000	TBD	Call TI	Call TI
TLVH431IDBZT	PREVIEW	SOT-23	DBZ	3	250	TBD	Call TI	Call TI
TLVH431IDCKR	PREVIEW	SC70	DCK	6	3000	TBD	Call TI	Call TI
TLVH431IDCKT	PREVIEW	SC70	DCK	6	250	TBD	Call TI	Call TI
TLVH431ILP	PREVIEW	TO-92	LP	3	1000	TBD	Call TI	Call TI
TLVH431ILPR	PREVIEW	TO-92	LP	3	2000	TBD	Call TI	Call TI
TLVH431IPK	PREVIEW	SOT-89	PK	3	1000	TBD	Call TI	Call TI
TLVH431QDBVR	PREVIEW	SOT-23	DBV	5	3000	TBD	Call TI	Call TI
TLVH431QDBVT	PREVIEW	SOT-23	DBV	5	250	TBD	Call TI	Call TI
TLVH431QDBZR	PREVIEW	SOT-23	DBZ	3	3000	TBD	Call TI	Call TI

Orderable Device	Status ⁽¹⁾	Package Type	Package Drawing	Pins	Package Qty	Eco Plan ⁽²⁾	Lead/Ball Finish	MSL Peak Temp ⁽³⁾
TLVH431QDBZT	PREVIEW	SOT-23	DBZ	3	250	TBD	Call TI	Call TI
TLVH431QDCKR	PREVIEW	SC70	DCK	6	3000	TBD	Call TI	Call TI
TLVH431QDCKT	PREVIEW	SC70	DCK	6	250	TBD	Call TI	Call TI
TLVH431QLP	PREVIEW	TO-92	LP	3	1000	TBD	Call TI	Call TI
TLVH431QLPR	PREVIEW	TO-92	LP	3	2000	TBD	Call TI	Call TI
TLVH431QPK	PREVIEW	SOT-89	PK	3	1000	TBD	Call TI	Call TI
TLVH432ACDBZR	PREVIEW	SOT-23	DBZ	3	3000	TBD	Call TI	Call TI
TLVH432ACDBZT	PREVIEW	SOT-23	DBZ	3	250	TBD	Call TI	Call TI
TLVH432ACPK	PREVIEW	SOT-89	PK	3	1000	TBD	Call TI	Call TI
TLVH432AIDBZR	PREVIEW	SOT-23	DBZ	3	3000	TBD	Call TI	Call TI
TLVH432AIDBZT	PREVIEW	SOT-23	DBZ	3	250	TBD	Call TI	Call TI
TLVH432AIPK	PREVIEW	SOT-89	PK	3	1000	TBD	Call TI	Call TI
TLVH432AQDBZR	PREVIEW	SOT-23	DBZ	3	3000	TBD	Call TI	Call TI
TLVH432AQDBZT	PREVIEW	SOT-23	DBZ	3	250	TBD	Call TI	Call TI
TLVH432AQP	PREVIEW	SOT-89	PK	3	1000	TBD	Call TI	Call TI
TLVH432BCDBZR	PREVIEW	SOT-23	DBZ	3	3000	TBD	Call TI	Call TI
TLVH432BCDBZT	PREVIEW	SOT-23	DBZ	3	250	TBD	Call TI	Call TI
TLVH432BCPK	PREVIEW	SOT-89	PK	3	1000	TBD	Call TI	Call TI
TLVH432BIDBZR	PREVIEW	SOT-23	DBZ	3	3000	TBD	Call TI	Call TI
TLVH432BIDBZT	PREVIEW	SOT-23	DBZ	3	250	TBD	Call TI	Call TI
TLVH432BIPK	PREVIEW	SOT-89	PK	3	1000	TBD	Call TI	Call TI
TLVH432BQDBZR	PREVIEW	SOT-23	DBZ	3	3000	TBD	Call TI	Call TI
TLVH432BQDBZT	PREVIEW	SOT-23	DBZ	3	250	TBD	Call TI	Call TI
TLVH432BQPK	PREVIEW	SOT-89	PK	3	1000	TBD	Call TI	Call TI
TLVH432CDBZR	PREVIEW	SOT-23	DBZ	3	3000	TBD	Call TI	Call TI
TLVH432CDBZT	PREVIEW	SOT-23	DBZ	3	250	TBD	Call TI	Call TI
TLVH432CPK	PREVIEW	SOT-89	PK	3	1000	TBD	Call TI	Call TI
TLVH432IDBZR	PREVIEW	SOT-23	DBZ	3	3000	TBD	Call TI	Call TI
TLVH432IDBZT	PREVIEW	SOT-23	DBZ	3	250	TBD	Call TI	Call TI
TLVH432IPK	PREVIEW	SOT-89	PK	3	1000	TBD	Call TI	Call TI
TLVH432QDBZR	PREVIEW	SOT-23	DBZ	3	3000	TBD	Call TI	Call TI
TLVH432QDBZT	PREVIEW	SOT-23	DBZ	3	250	TBD	Call TI	Call TI
TLVH432QPK	PREVIEW	SOT-89	PK	3	1000	TBD	Call TI	Call TI

⁽¹⁾ The marketing status values are defined as follows:

ACTIVE: Product device recommended for new designs.

LIFEBUY: TI has announced that the device will be discontinued, and a lifetime-buy period is in effect.

NRND: Not recommended for new designs. Device is in production to support existing customers, but TI does not recommend using this part in a new design.

PREVIEW: Device has been announced but is not in production. Samples may or may not be available.

OBSELETE: TI has discontinued the production of the device.

⁽²⁾ Eco Plan - The planned eco-friendly classification: Pb-Free (RoHS) or Green (RoHS & no Sb/Br) - please check <http://www.ti.com/productcontent> for the latest availability information and additional product content details.

TBD: The Pb-Free/Green conversion plan has not been defined.

Pb-Free (RoHS): TI's terms "Lead-Free" or "Pb-Free" mean semiconductor products that are compatible with the current RoHS requirements for all 6 substances, including the requirement that lead not exceed 0.1% by weight in homogeneous materials. Where designed to be soldered at high temperatures, TI Pb-Free products are suitable for use in specified lead-free processes.

Green (RoHS & no Sb/Br): TI defines "Green" to mean Pb-Free (RoHS compatible), and free of Bromine (Br) and Antimony (Sb) based flame retardants (Br or Sb do not exceed 0.1% by weight in homogeneous material)

⁽³⁾ MSL, Peak Temp. -- The Moisture Sensitivity Level rating according to the JEDEC industry standard classifications, and peak solder temperature.

Important Information and Disclaimer:The information provided on this page represents TI's knowledge and belief as of the date that it is provided. TI bases its knowledge and belief on information provided by third parties, and makes no representation or warranty as to the accuracy of such information. Efforts are underway to better integrate information from third parties. TI has taken and continues to take reasonable steps to provide representative and accurate information but may not have conducted destructive testing or chemical analysis on incoming materials and chemicals. TI and TI suppliers consider certain information to be proprietary, and thus CAS numbers and other limited information may not be available for release.

In no event shall TI's liability arising out of such information exceed the total purchase price of the TI part(s) at issue in this document sold by TI to Customer on an annual basis.

MECHANICAL DATA

PK (R-PSS0-F3)

PLASTIC SINGLE-IN-LINE PACKAGE

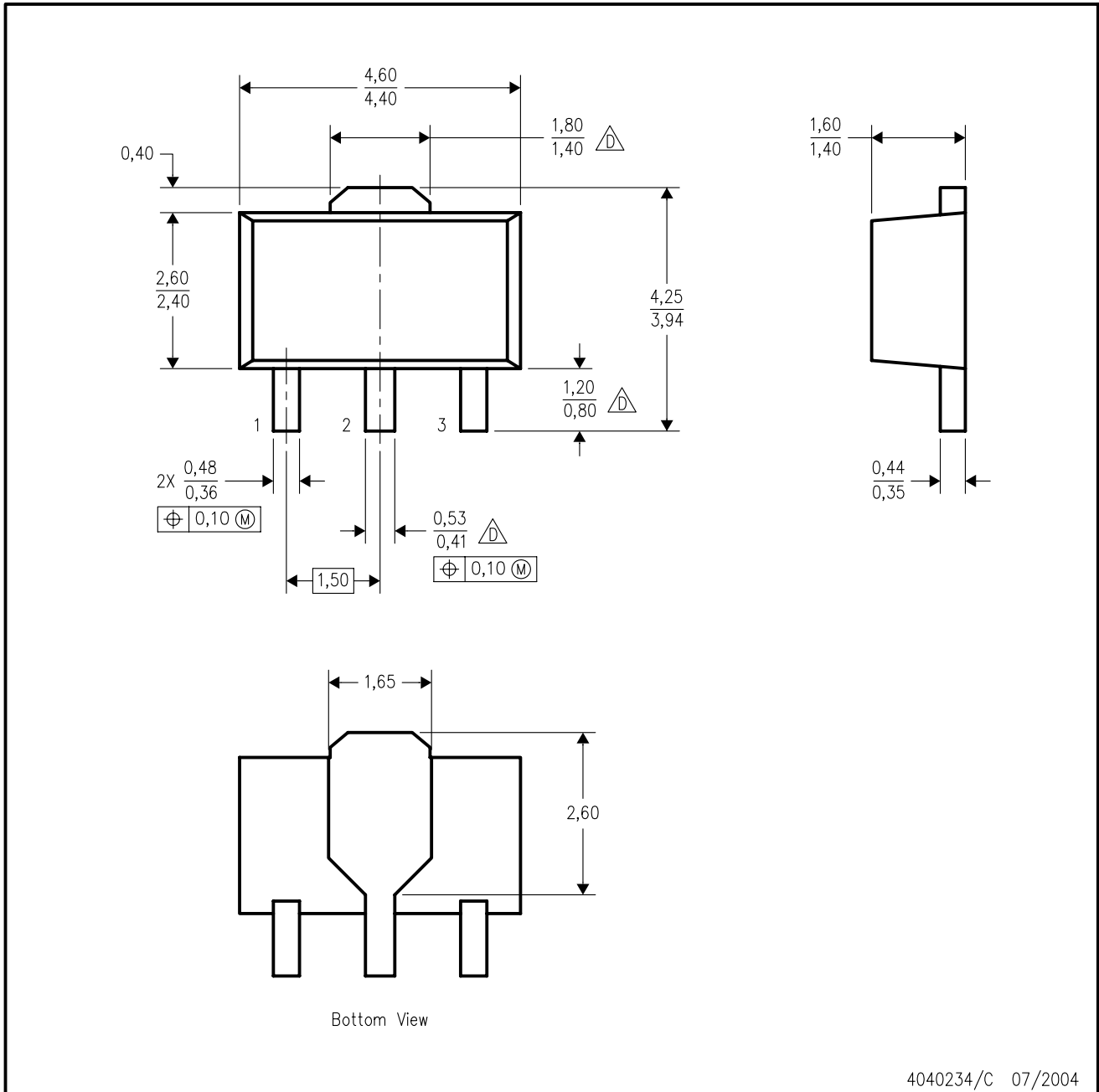

4040234/C 07/2004

- NOTES:
- A. All linear dimensions are in millimeters. Dimensioning and tolerancing per ASME Y14.5-1994.
 - B. This drawing is subject to change without notice.
 - C. The center lead is in electrical contact with the tab.
- Δ Falls within JEDEC TO-243 variation AA, except minimum lead length, pin 2 minimum lead width, and minimum tab width.

MECHANICAL DATA

DBV (R-PDSO-G5)

PLASTIC SMALL-OUTLINE PACKAGE

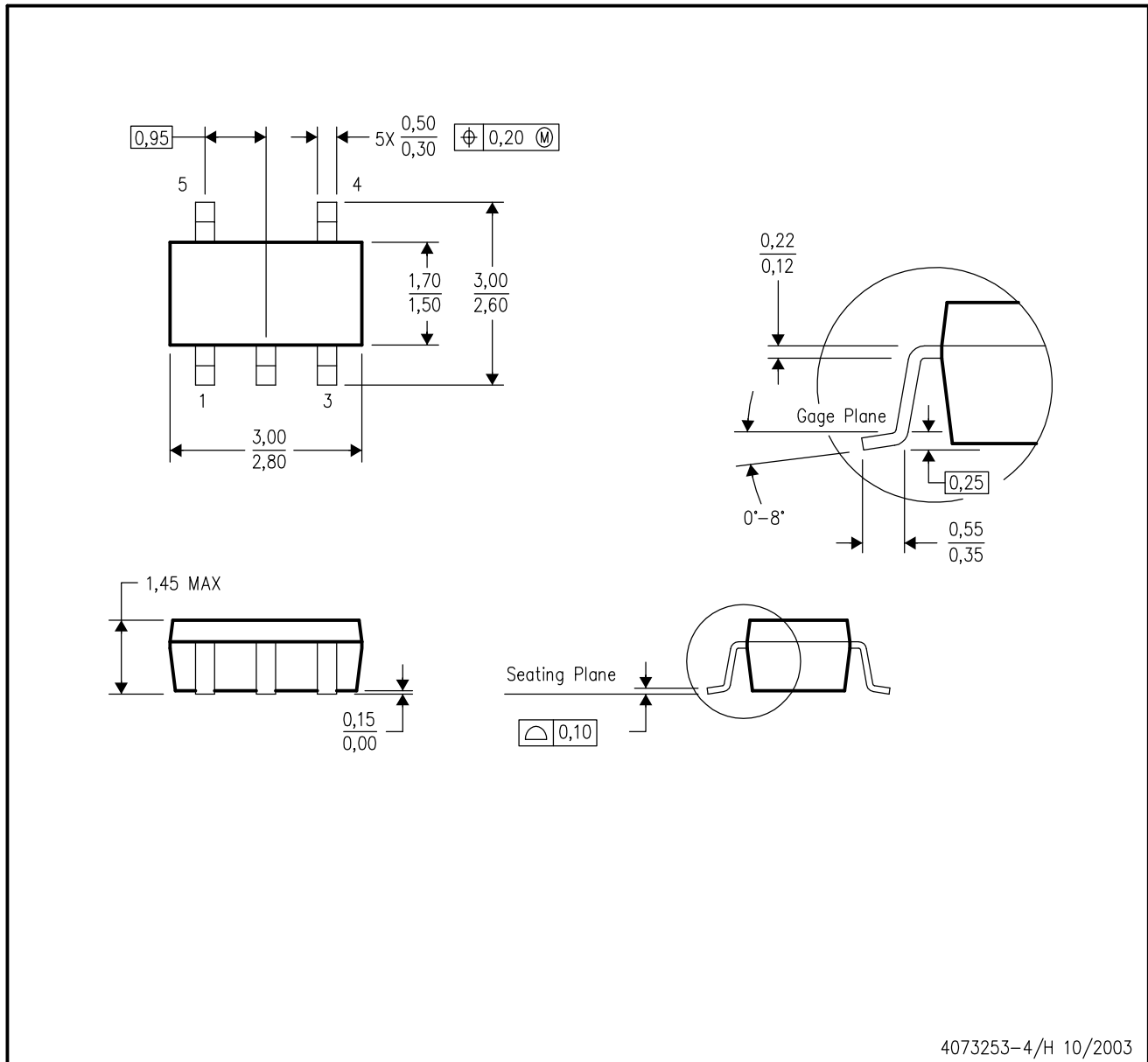

- NOTES:
- A. All linear dimensions are in millimeters.
 - B. This drawing is subject to change without notice.
 - C. Body dimensions do not include mold flash or protrusion.
 - D. Falls within JEDEC MO-178 Variation AA.

MECHANICAL DATA

MPDS108 – AUGUST 2001

DBZ (R-PDSO-G3)

PLASTIC SMALL-OUTLINE

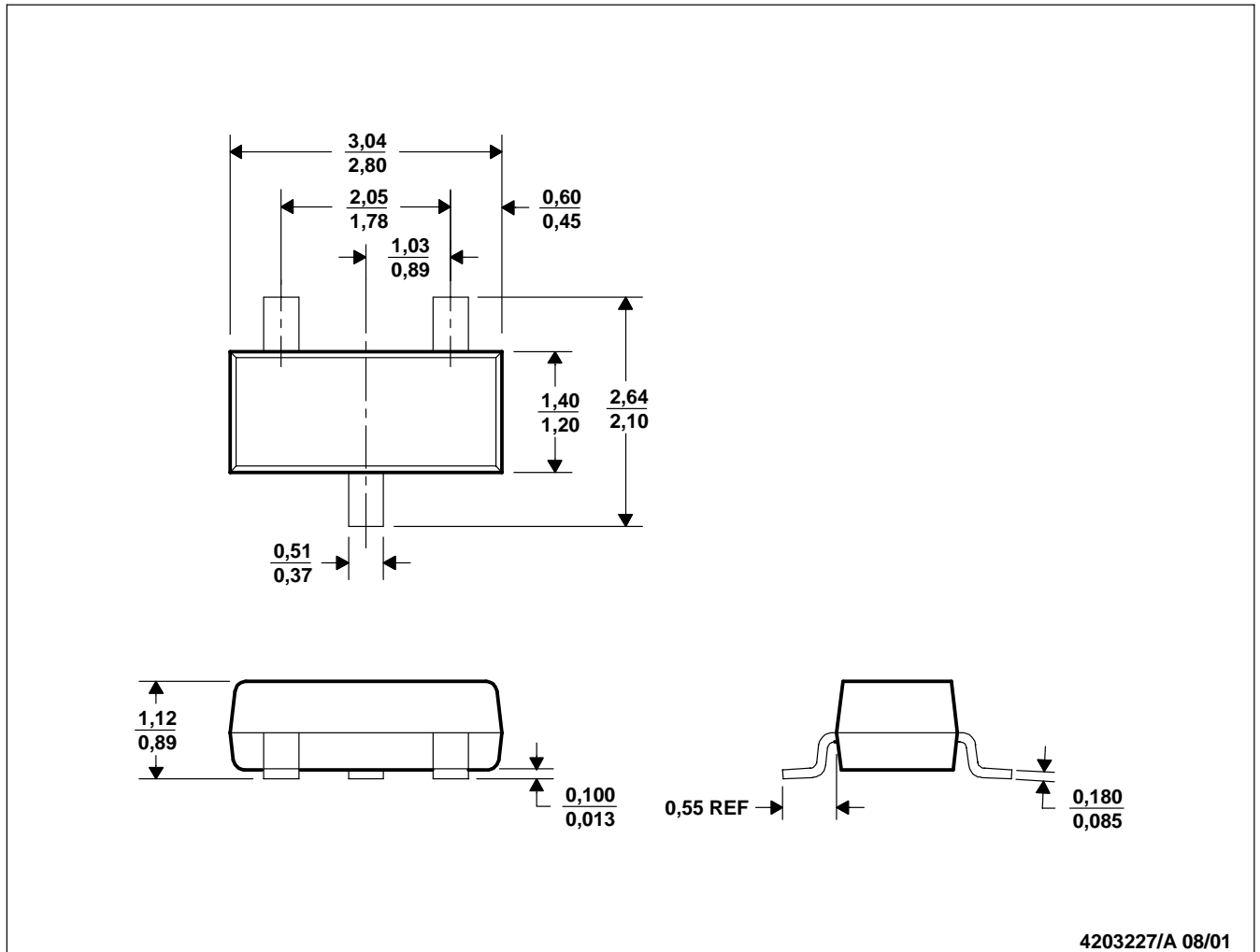

4203227/A 08/01

- NOTES:
- A. All linear dimensions are in millimeters.
 - B. This drawing is subject to change without notice.
 - C. Dimensions are inclusive of plating.
 - D. Dimensions are exclusive of mold flash and metal burr.

MECHANICAL DATA

MPDS114 – FEBRUARY 2002

DCK (R-PDSO-G6)

PLASTIC SMALL-OUTLINE PACKAGE

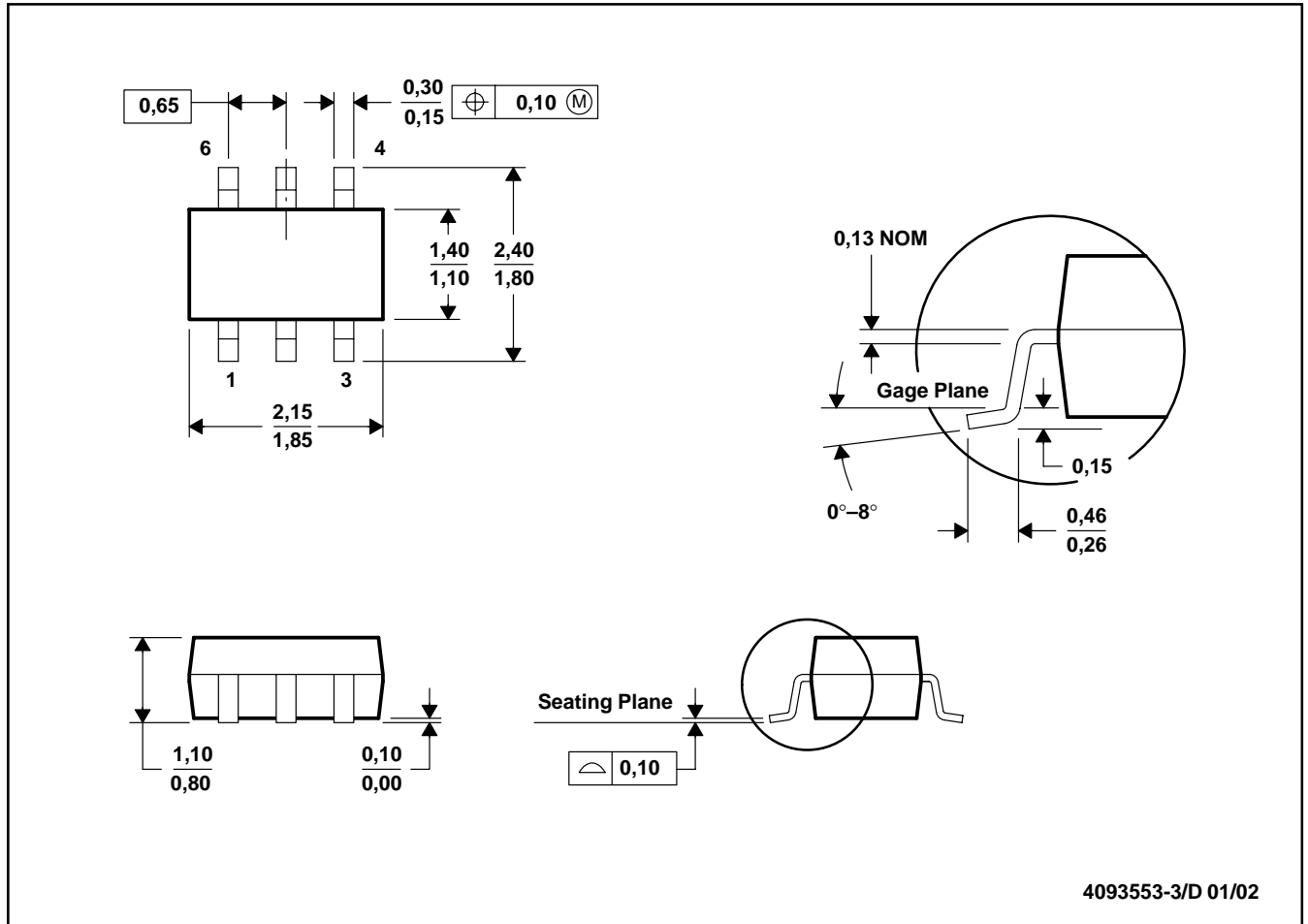

- NOTES: A. All linear dimensions are in millimeters.
 B. This drawing is subject to change without notice.
 C. Body dimensions do not include mold flash or protrusion.
 D. Falls within JEDEC MO-203

MECHANICAL DATA

MSOT002A – OCTOBER 1994 – REVISED NOVEMBER 2001

LP (O-PBCY-W3)

PLASTIC CYLINDRICAL PACKAGE

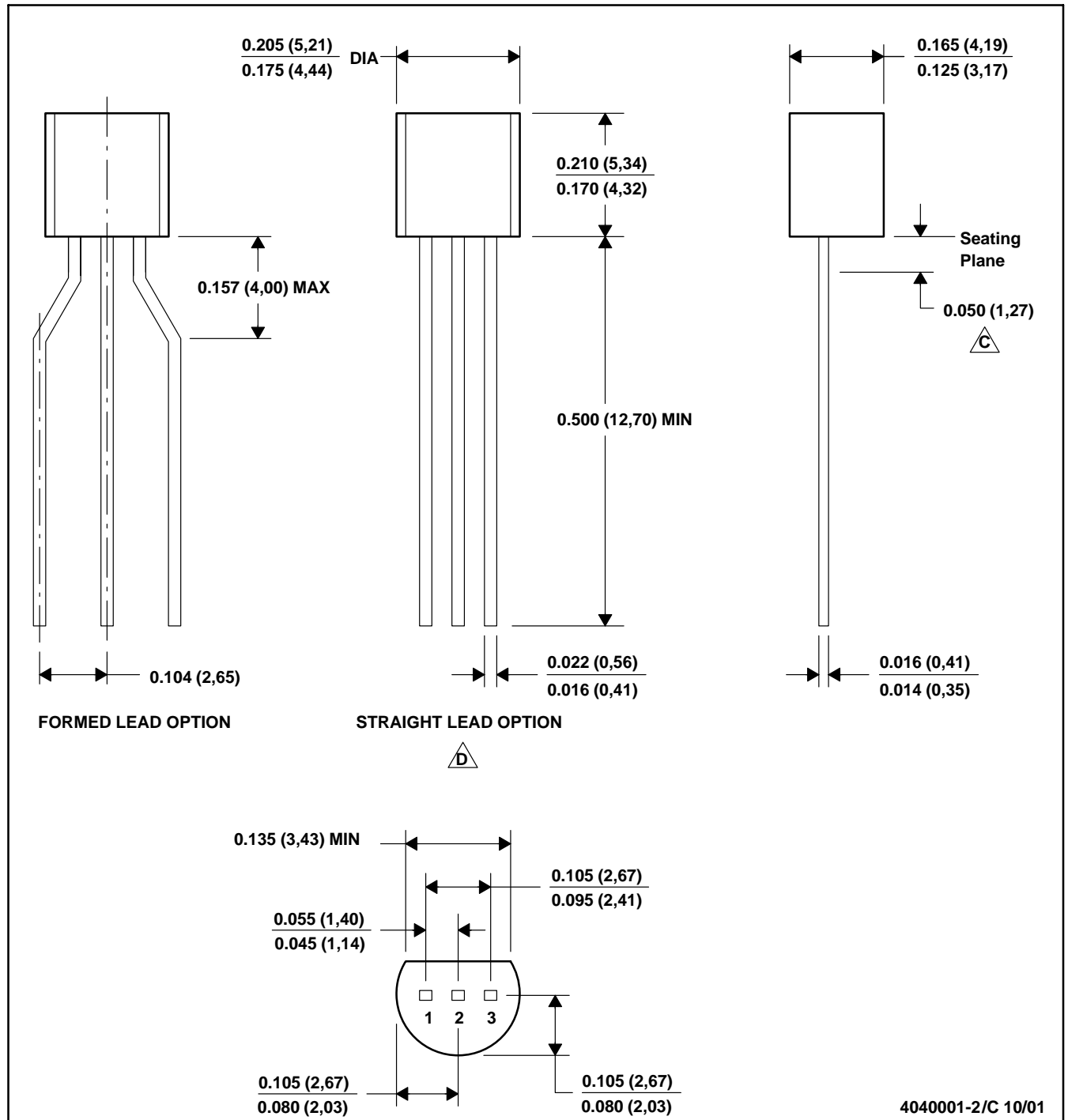

4040001-2/C 10/01

MECHANICAL DATA

MSOT002A – OCTOBER 1994 – REVISED NOVEMBER 2001

LP (O-PBCY-W3)

PLASTIC CYLINDRICAL PACKAGE

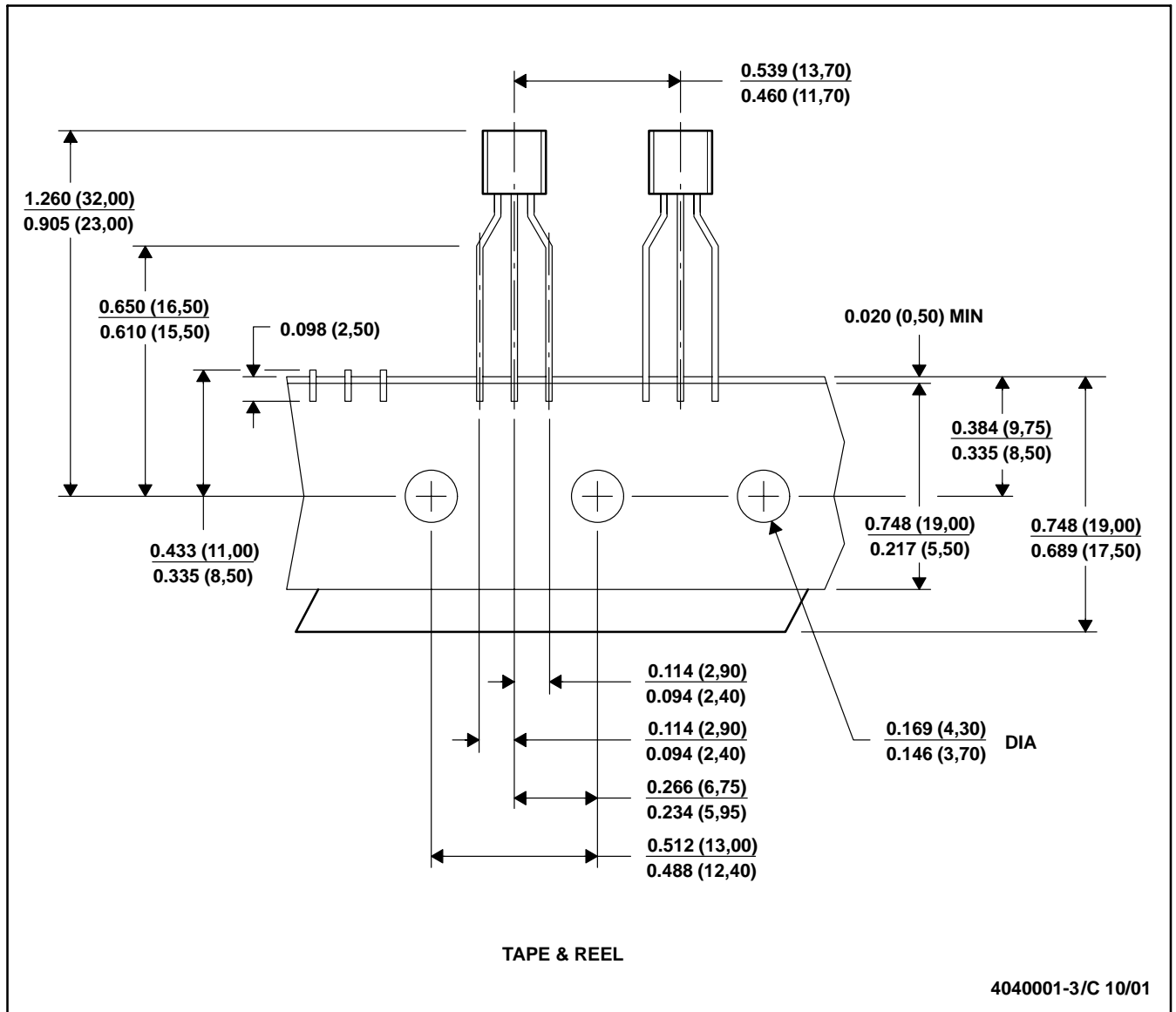

- NOTES: A. All linear dimensions are in inches (millimeters).
 B. This drawing is subject to change without notice.
 C. Tape and Reel information for the Format Lead Option package.

IMPORTANT NOTICE

Texas Instruments Incorporated and its subsidiaries (TI) reserve the right to make corrections, modifications, enhancements, improvements, and other changes to its products and services at any time and to discontinue any product or service without notice. Customers should obtain the latest relevant information before placing orders and should verify that such information is current and complete. All products are sold subject to TI's terms and conditions of sale supplied at the time of order acknowledgment.

TI warrants performance of its hardware products to the specifications applicable at the time of sale in accordance with TI's standard warranty. Testing and other quality control techniques are used to the extent TI deems necessary to support this warranty. Except where mandated by government requirements, testing of all parameters of each product is not necessarily performed.

TI assumes no liability for applications assistance or customer product design. Customers are responsible for their products and applications using TI components. To minimize the risks associated with customer products and applications, customers should provide adequate design and operating safeguards.

TI does not warrant or represent that any license, either express or implied, is granted under any TI patent right, copyright, mask work right, or other TI intellectual property right relating to any combination, machine, or process in which TI products or services are used. Information published by TI regarding third-party products or services does not constitute a license from TI to use such products or services or a warranty or endorsement thereof. Use of such information may require a license from a third party under the patents or other intellectual property of the third party, or a license from TI under the patents or other intellectual property of TI.

Reproduction of information in TI data books or data sheets is permissible only if reproduction is without alteration and is accompanied by all associated warranties, conditions, limitations, and notices. Reproduction of this information with alteration is an unfair and deceptive business practice. TI is not responsible or liable for such altered documentation.

Resale of TI products or services with statements different from or beyond the parameters stated by TI for that product or service voids all express and any implied warranties for the associated TI product or service and is an unfair and deceptive business practice. TI is not responsible or liable for any such statements.

Following are URLs where you can obtain information on other Texas Instruments products and application solutions:

Products		Applications	
Amplifiers	amplifier.ti.com	Audio	www.ti.com/audio
Data Converters	dataconverter.ti.com	Automotive	www.ti.com/automotive
DSP	dsp.ti.com	Broadband	www.ti.com/broadband
Interface	interface.ti.com	Digital Control	www.ti.com/digitalcontrol
Logic	logic.ti.com	Military	www.ti.com/military
Power Mgmt	power.ti.com	Optical Networking	www.ti.com/opticalnetwork
Microcontrollers	microcontroller.ti.com	Security	www.ti.com/security
		Telephony	www.ti.com/telephony
		Video & Imaging	www.ti.com/video
		Wireless	www.ti.com/wireless

Mailing Address: Texas Instruments
Post Office Box 655303 Dallas, Texas 75265