



Micro Commercial Components
21201 Itasca Street Chatsworth
CA 91311
Phone: (818) 701-4933
Fax: (818) 701-4939

TSMBJ1009C-130

Features

- Oxide-Glass passivated Junction
- Bi-Directional protection in a single device
- Surge capabilities up to 100A@10/1000us or 400A@8/20us
- High Off-State impedance and Low On-State voltage
- Plastic material has UL flammability classification 94V-0

Transient Voltage Protection Device 120 Volts

Mechanical Data

- Case : Molded plastic
- Polarity : None cathode band denotes
- Approx Weight : 0.093grams

Maximum Ratings

Characteristic	Symbol	Value	Unit
Non-repetitive peak impulse current	I_{PP}	100A	10/1000us
Non-repetitive peak On-state current	I_{TSM}	50A	8.3ms, one-half cycle
Operating temperature range	T_{OP}	-40~150°C	
Junction and storage temperature range	T_J, T_{STG}	-55~150°C	

Thermal Resistance

Characteristic	Symbol	Value	Unit
Thermal Resistance junction to lead	$R_{\theta JL}$	20°C/W	
Thermal Resistance junction to ambient	$R_{\theta JA}$	100°C/W	On recommended pad layout
Typical positive temperature coefficient for breakdown voltage	$\Delta V_{BR}/\Delta T_J$	0.1%/°C	

DO-214AA (SMBJ)

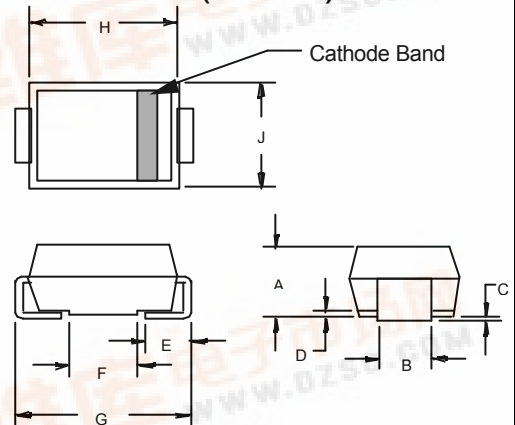

DIM	INCHES		MM		NOTE
	MIN	MAX	MIN	MAX	
A	.078	.096	2.00	2.44	
B	.077	.083	1.96	2.10	
C	.002	.008	.05	.20	
D	---	.02	---	.51	
E	.030	.060	.76	1.52	
F	.065	.091	1.65	2.32	
G	.205	.220	5.21	5.59	
H	.160	.180	4.06	4.57	
J	.130	.155	3.30	3.94	

SUGGESTED SOLDER PAD LAYOUT

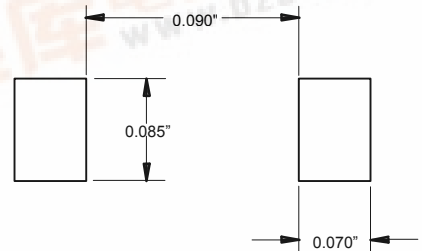

TSMBJ1009C-130



ELECTRICAL CHARACTERISTIC @25°C Unless otherwise specified

Parameter	Rated Repetitive Off-state Voltage	Off-state Leakage Current@ V_{DRM}	Breakover Voltage	On-State Voltage @ $I_T=1.0A$	Breakover Current		Holding Current		Off-State Capacitance
					I_{BO}	I_{BO+}	I_H	I_{H+}	
Symbol	V_{DRM}	I_{DRM}	V_{BO}	V_T	I_{BO}	I_{BO+}	I_H	I_{H+}	C_i
Units	Volts	μA	Volts	Volts	mA	mA	mA	mA	pF
Limit	Max	Max	Max	Max	Min	Max	Min	Max	Typ.
TSMBJ1009C-130	120	5	160	5	50	800	150	800	120

MAXIMUM RATED SURGE WAVEFORM

Waveform	Standard	I_{pp} (A)
2/10 us	GR-1089-CORE	500
8/20 us	IEC 61000-4-5	400
10/160 us	FCC Part 68	200
10/700 us	ITU-T K20/21	200
10/560 us	FCC Part 68	150
10/1000 us	GR-1089-CORE	100

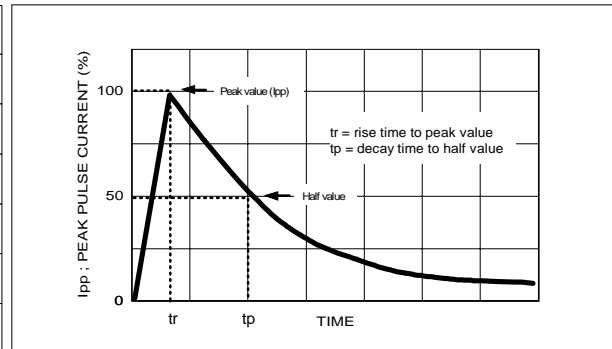

Symbol	Parameter	
V_{DRM}	Stand-off voltage	
I_{DRM}	Leakage current at stand-off voltage	
V_{BR}	Breakdown voltage	
I_{BR}	Breakdown current	
V_{BO}	Breakover voltage	
I_{BO}	Breakover current	
I_H	Holding current	NOTE: 1
V_T	On state voltage	
I_{PP}	Peak pulse current	
C_O	Off-state capacitance	NOTE: 2

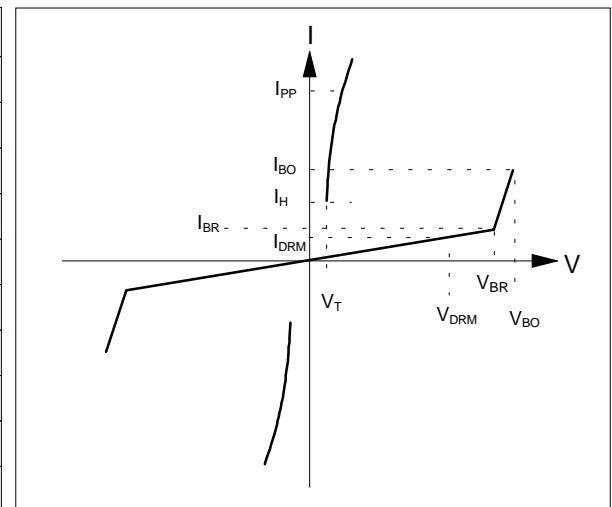

NOTE :

- $I_H > (V_L / R_L)$ If this criterion is not obeyed, the TSPD triggers but does not return correctly to high-resistance state. The surge recovery time. It does not exceed 30ms.
- Off-state capacitance measured at $f=1.0MHz$, $1.0V_{rms}$ signal, $V_R=2V_{dc}$ bias.

TSMBJ1009C-130

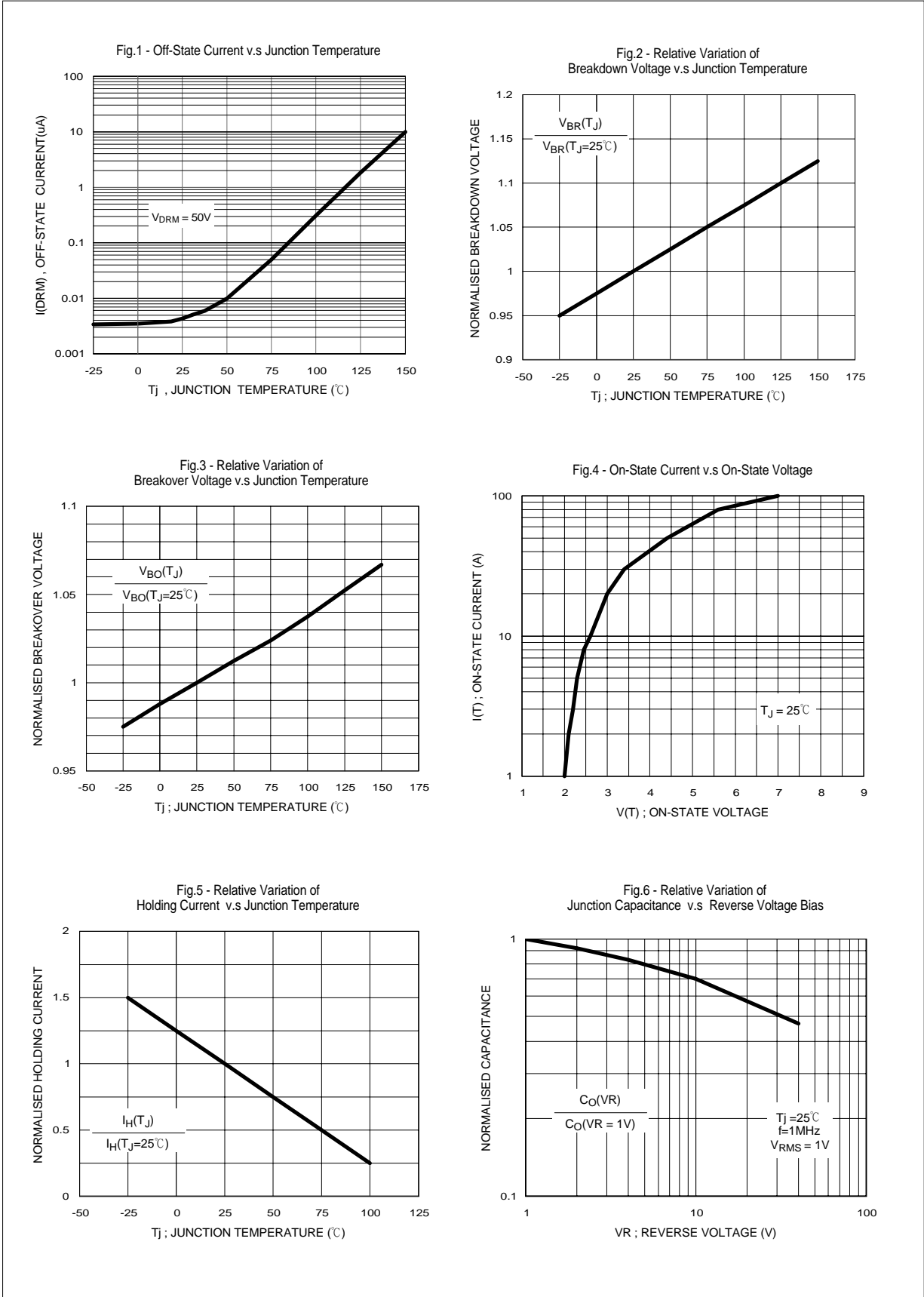

TYPICAL APPLICATION CIRCUITS

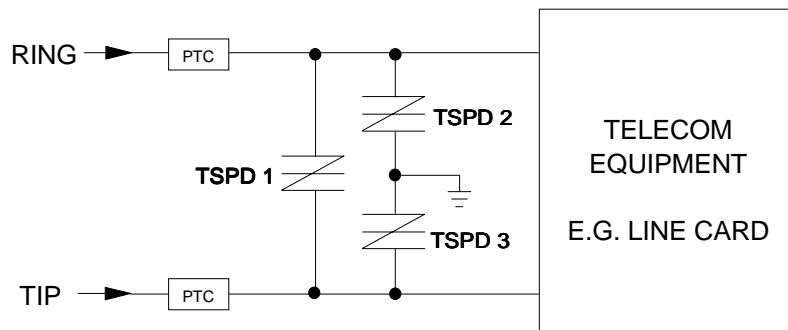
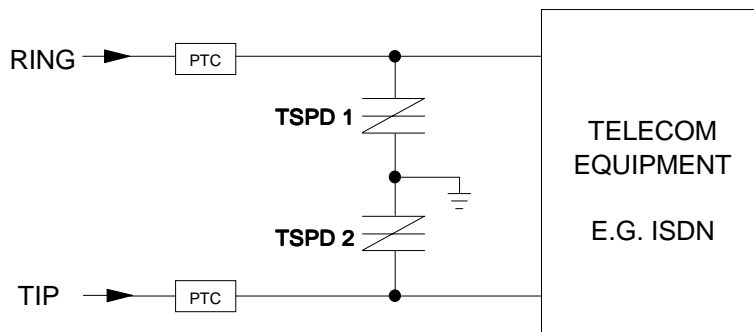
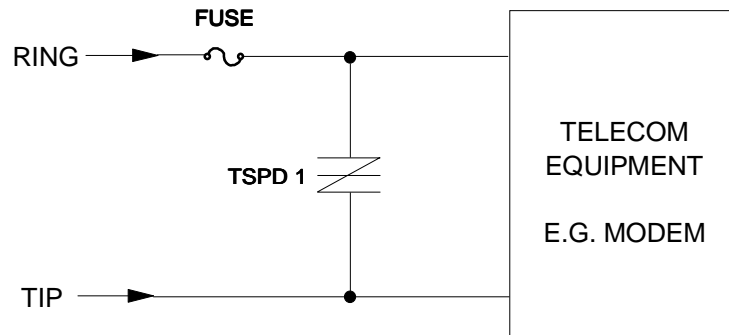

The PTC (Positive Temperature Coefficient) is an overcurrent protection device.