

## Programmable Multi-Chemistry Fast-Charge Management IC

### Features

- Safe management of fast charge for NiCd, NiMH, or Li-Ion battery packs
- High-frequency switching controller for efficient and simple charger design
- Pre-charge qualification for detecting shorted, damaged, or overheated cells
- Fast-charge termination by  $\Delta T/\Delta t$  minimum current (Li-Ion), maximum temperature, and maximum charge time
- Selectable top-off mode for achieving maximum capacity in NiMH batteries
- Programmable trickle-charge mode for reviving deeply discharged batteries and for post-charge maintenance
- Built-in battery removal and insertion detection
- Sleep mode for low power consumption

### General Description

The bq2000T is a programmable, monolithic IC for fast-charge management of nickel cadmium (NiCd), nickel metal-hydride (NiMH), or lithium-ion (Li-Ion) batteries in single- or multi-chemistry applications. The bq2000T detects the battery chemistry and proceeds with the optimal charging and termination algorithms. This process eliminates undesirable undercharged or overcharged conditions and allows accurate and safe termination of fast charge.

Depending on the chemistry, the bq2000T provides a number of charge termination criteria:

- Rate of temperature rise,  $\Delta T/\Delta t$  (for NiCd and NiMH)
- Minimum charging current (for Li-Ion)
- Maximum temperature
- Maximum charge time

For safety, the bq2000T inhibits fast charge until the battery voltage and temperature are within user-defined limits. If the battery voltage is below the low-voltage threshold, the bq2000T uses trickle-charge to condition the battery. For NiMH batteries, the bq2000T provides an optional top-off charge to maximize the battery capacity.

The integrated high-frequency comparator allows the bq2000T to be the basis for a complete, high-efficiency power-conversion circuit for both nickel-based and lithium-based chemistries.

### Pin Connections

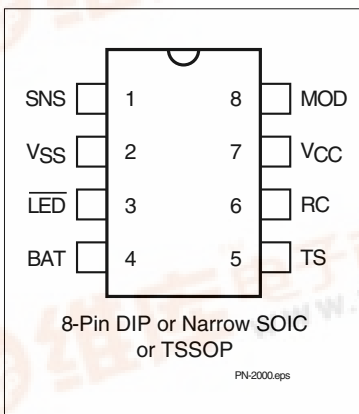

### Pin Names

SNS	Current-sense input	TS	Temperature-sense input
VSS	System ground	RC	Timer-program input
LED	Charge-status output	VCC	Supply-voltage input
BAT	Battery-voltage input	MOD	Modulation-control output



# bq2000T

## Pin Descriptions

### SNS Current-sense input

Enables the bq2000T to sense the battery current via the voltage developed on this pin by an external sense-resistor connected in series with the battery pack

### V<sub>SS</sub> System Ground

### LED Charge-status output

Open-drain output that indicates the charging status by turning on, turning off, or flashing an external LED

### BAT Battery-voltage input

Battery-voltage sense input. A simple resistive divider, across the battery terminals, generates this input.

### TS Temperature-sense input

Input for an external battery-temperature monitoring circuit. An external resistive divider network with a negative temperature-coefficient thermistor sets the lower and upper temperature thresholds.

### RC Timer-program input

RC input used to program the maximum charge-time, hold-off period, and trickle rate during the charge cycle, and to disable or enable top-off charge

### V<sub>CC</sub> Supply-voltage input

### MOD Modulation-control output

Push-pull output that controls the charging current to the battery. MOD switches high to enable charging current to flow and low to inhibit charging-current flow.

## Functional Description

The bq2000T is a versatile, multi-chemistry battery-charge control device. See Figure 1 for a functional block diagram and Figure 2 for the state diagram.

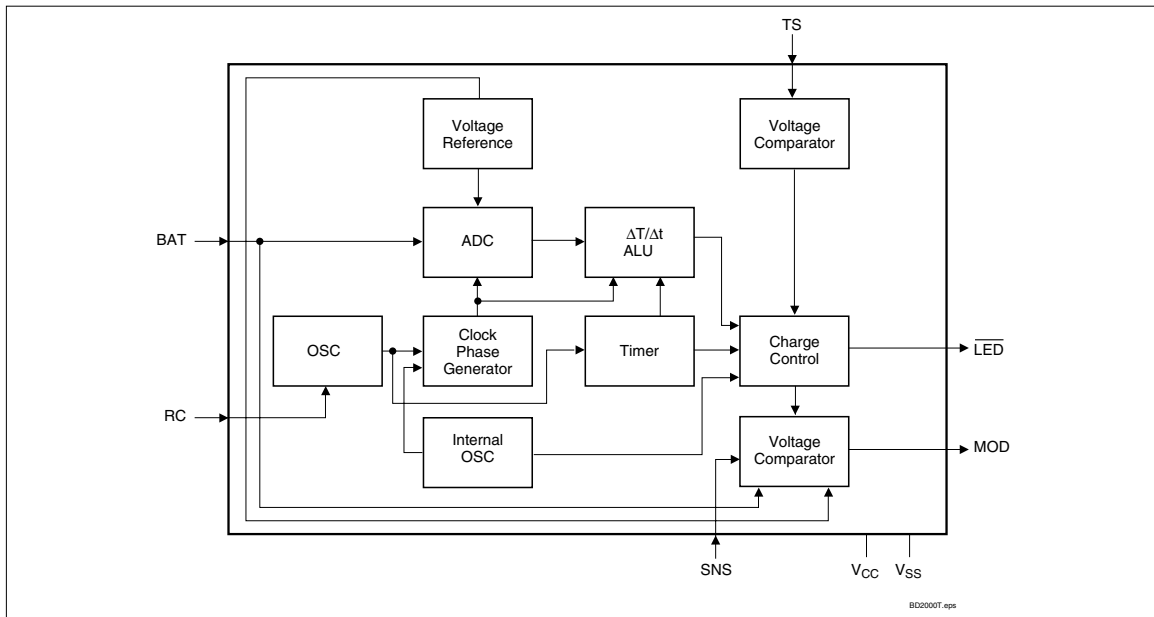

Figure 1. Functional Block Diagram

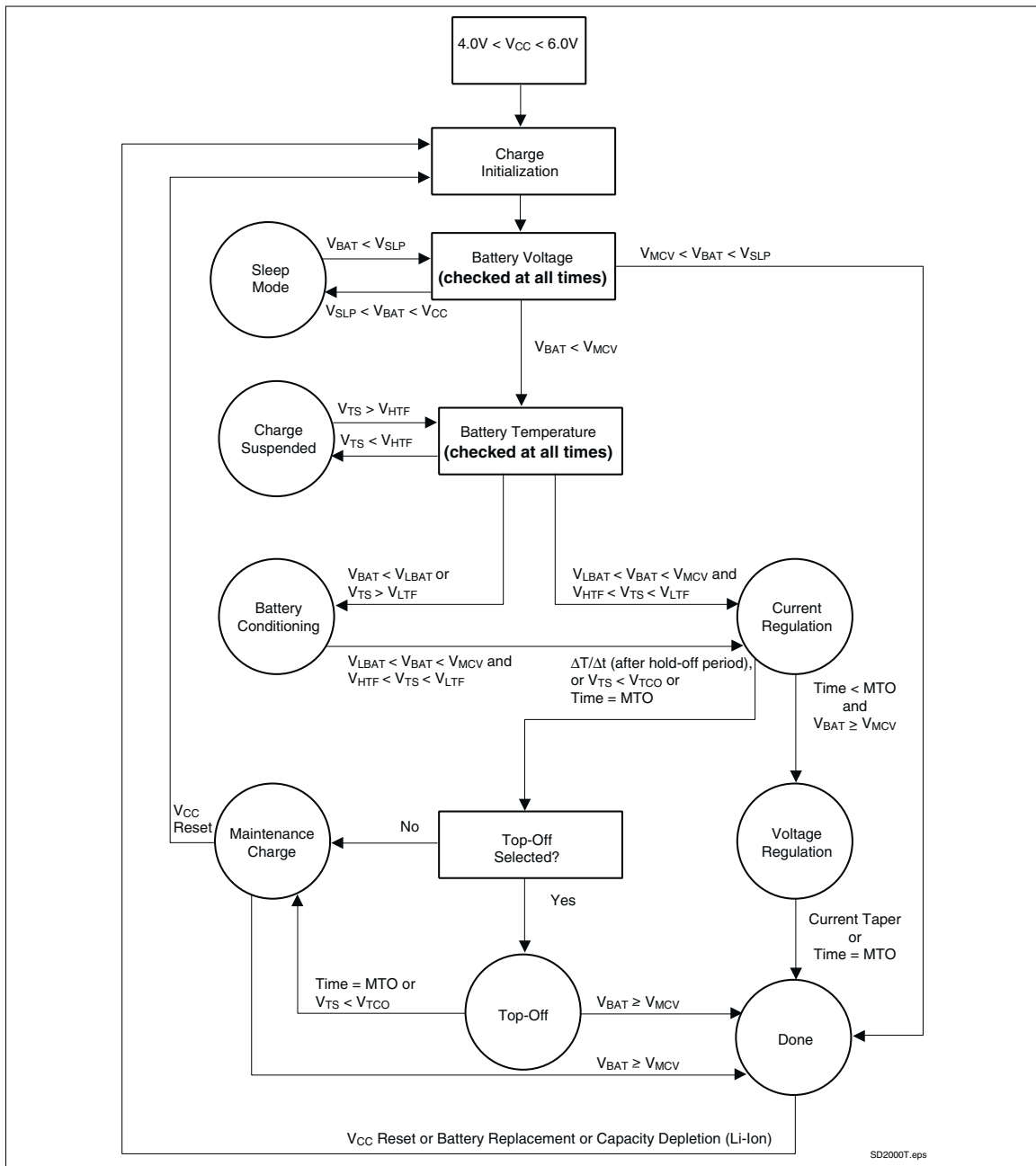

Figure 2. State Diagram

# bq2000T

## Initiation and Charge Qualification

The bq2000T initiates a charge cycle when it detects

- Application of power to  $V_{CC}$
- Battery replacement
- Exit from sleep mode
- Capacity depletion (Li-Ion only)

Immediately following initiation, the IC enters a charge-qualification mode. The bq2000T charge qualification is based on battery voltage and temperature. If voltage on pin BAT is less than the internal threshold,  $V_{LBAT}$ , the bq2000T enters the charge-pending state. This condition indicates the possibility of a defective or shorted battery pack. In an attempt to revive a fully depleted pack, the bq2000T enables the MOD pin to trickle-charge at a rate of once every 1.0s. As explained in the section “Top-Off and Pulse-Trickle Charge,” the trickle pulse-width is user-selectable and is set by the value of the resistance connected to pin RC.

During this period, the  $\overline{LED}$  pin blinks at a 1Hz rate, indicating the pending status of the charger.

Similarly, the bq2000T suspends fast charge if the battery temperature is outside the  $V_{LTF}$  to  $V_{HTF}$  range. (See Table 4.) For safety reasons, however, it disables the pulse trickle, in the case of a battery over-temperature condition (i.e.,  $V_{TS} < V_{HTF}$ ). Fast charge begins when the battery temperature and voltage are valid.

## Battery Chemistry

The bq2000T detects the battery chemistry by monitoring the battery-voltage profile during fast charge. If the voltage on BAT input rises to the internal  $V_{MCV}$  reference, the IC assumes a Li-Ion battery. Otherwise the bq2000T assumes NiCd/NiMH chemistry.

As shown in Figure 6, a resistor voltage-divider between the battery pack’s positive terminal and  $V_{SS}$  scales the battery voltage measured at pin BAT. In a mixed-chemistry design, a common voltage-divider is used as long as the maximum charge voltage of the nickel-based pack is below that of the Li-Ion pack. Otherwise, different scaling is required.

Once the chemistry is determined, the bq2000T completes the fast charge with the appropriate charge algorithm (Table 1). The user can customize the algorithm by programming the device using an external resistor and a capacitor connected to the RC pin, as discussed in later sections.

## NiCd and NiMH Batteries

Following qualification, the bq2000T fast-charges NiCd or NiMH batteries using a current-limited algorithm. During the fast-charge period, it monitors charge time, temperature, and voltage for adherence to the termination criteria. This monitoring is further explained in later sections. Following fast charge, the battery is topped off, if top-off is selected. The charging cycle ends

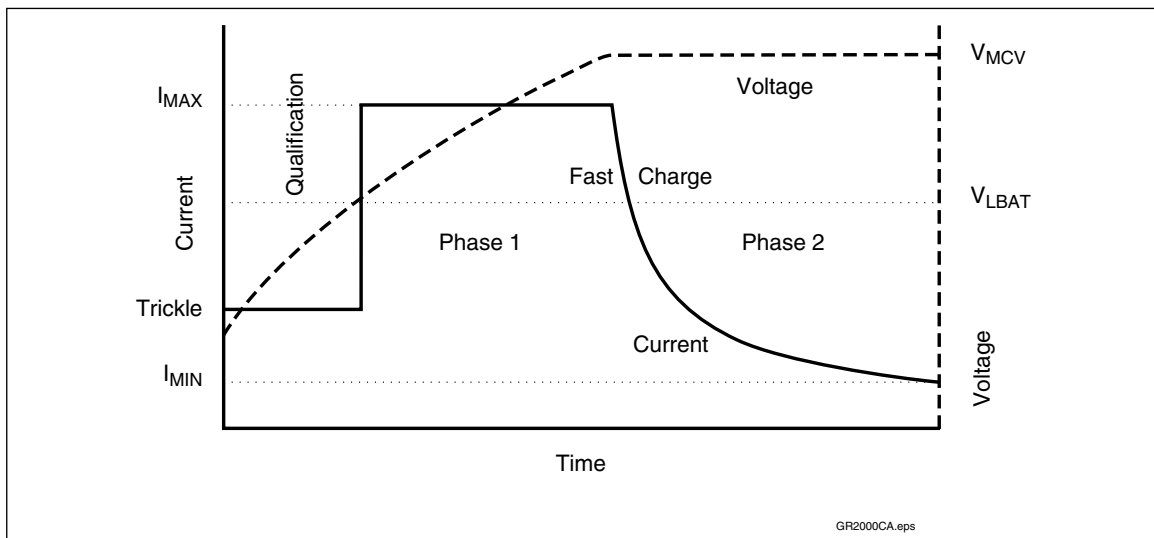

Figure 3. Lithium-Ion Charge Algorithm

**Table 1. Charge Algorithm**

Battery Chemistry	Charge Algorithm
NiCd or NiMH	<ol style="list-style-type: none"> <li>1. Charge qualification</li> <li>2. Trickle charge, if required</li> <li>3. Fast charge (constant current)</li> <li>4. Charge termination (<math>\Delta T/\Delta t</math>, time)</li> <li>5. Top-off (optional)</li> <li>6. Trickle charge</li> </ol>
Li-Ion	<ol style="list-style-type: none"> <li>1. Charge qualification</li> <li>2. Trickle charge, if required</li> <li>3. Two-step fast charge (constant current followed by constant voltage)</li> <li>4. Charge termination (minimum current, time)</li> </ol>

with a trickle maintenance-charge that continues as long as the voltage on pin BAT remains below  $V_{MCV}$ .

### Lithium-Ion Batteries

The bq2000T uses a two-phase fast-charge algorithm for Li-Ion batteries (Figure 3). In phase one, the bq2000T regulates constant current until  $V_{BAT}$  rises to  $V_{MCV}$ . The bq2000T then moves to phase two, regulates the battery with constant voltage of  $V_{MCV}$ , and terminates when the charging current falls below the  $I_{MIN}$  threshold. A new charge cycle is started if the cell voltage falls below the  $V_{RCH}$  threshold.

During the current-regulation phase, the bq2000T monitors charge time, battery temperature, and battery voltage for adherence to the termination criteria. During the final constant-voltage stage, in addition to the charge time and temperature, it monitors the charge current as a termination criterion. There is no post-charge maintenance mode for Li-Ion batteries.

### Charge Termination

#### Maximum Charge Time (NiCd, NiMH, and Li-Ion)

The bq2000T sets the maximum charge-time through pin RC. With the proper selection of external resistor and capacitor, various time-out values may be achieved. Figure 4 shows a typical connection.

The following equation shows the relationship between the  $R_{MTO}$  and  $C_{MTO}$  values and the maximum charge time (MTO) for the bq2000T:

$$MTO = R_{MTO} * C_{MTO} * 35,988$$

MTO is measured in minutes,  $R_{MTO}$  in ohms, and  $C_{MTO}$  in farads. (**Note:**  $R_{MTO}$  and  $C_{MTO}$  values also determine other features of the device. See Tables 2 and 3 for details.)

For Li-Ion cells, the bq2000T resets the MTO when the battery reaches the constant-voltage phase of the

charge. This feature provides the additional charge time required for Li-Ion cells.

### Maximum Temperature (NiCd, NiMH, Li-Ion)

A negative-coefficient thermistor, referenced to  $V_{SS}$  and placed in thermal contact with the battery, may be used as a temperature-sensing device. Figure 5 shows a typical temperature-sensing circuit.

During fast charge, the bq2000T compares the battery temperature to an internal high-temperature cutoff threshold,  $V_{TCC}$ . As shown in Table 4, high-temperature termination occurs when voltage at pin TS is less than this threshold.

### $\Delta T/\Delta t$ (NiCd, NiMH)

When fast charging, the bq2000T monitors the voltage at pin TS for rate of temperature change detection,  $\Delta T/\Delta t$ . The bq2000T samples the voltage at the TS pin every 16s and compares it to the value measured 2 samples earlier. This feature terminates fast charge if this voltage declines at a rate of

$$\frac{V_{CC}}{161} \left( \frac{V}{Min} \right)$$

Figure 5 shows a typical connection diagram.

### Minimum Current (Li-Ion Only)

The bq2000T monitors the charging current during the voltage-regulation phase of Li-Ion batteries. Fast charge is terminated when the current is tapered off to 7% of the maximum charging current. **Please note that this threshold is different for the bq2000.**

### Initial Hold-Off Period

The values of the external resistor and capacitor connected to pin RC set the initial hold-off period. During this period, the bq2000T avoids early termination by disabling the  $\Delta T/\Delta t$  feature. This period is fixed at the

# bq2000T

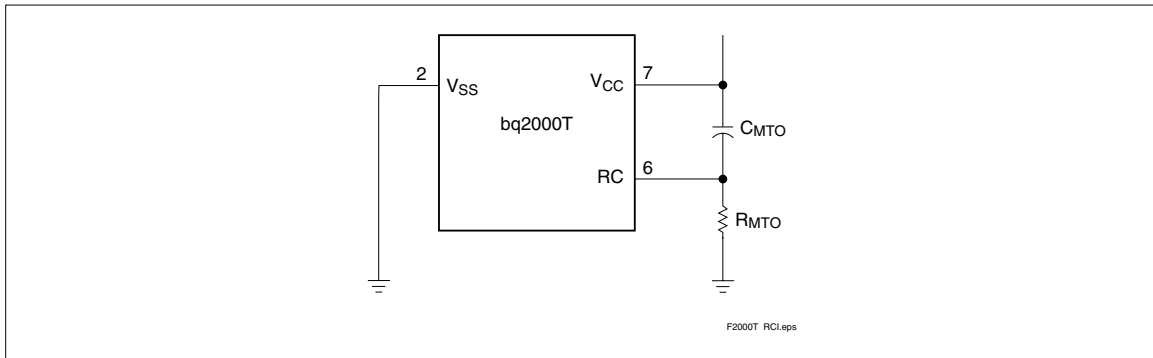

Figure 4. Typical Connection for the RC Input

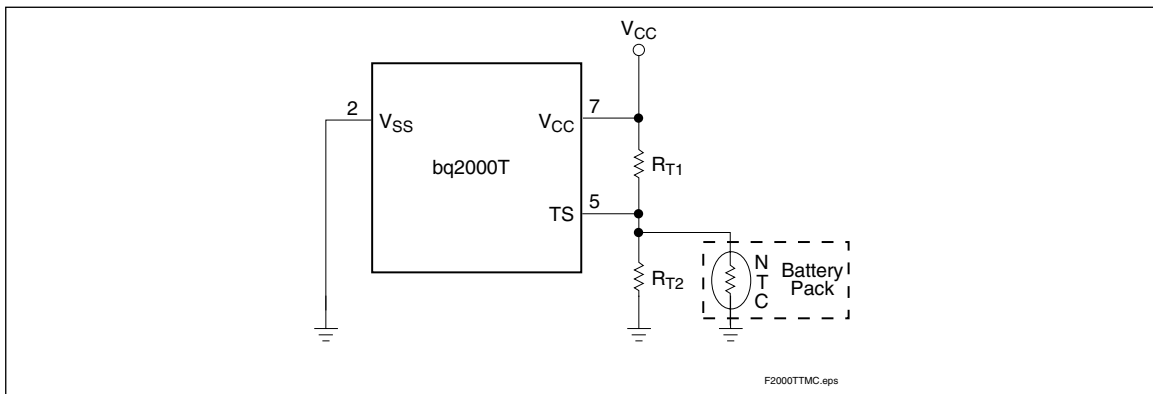

Figure 5. Temperature Monitoring Configuration

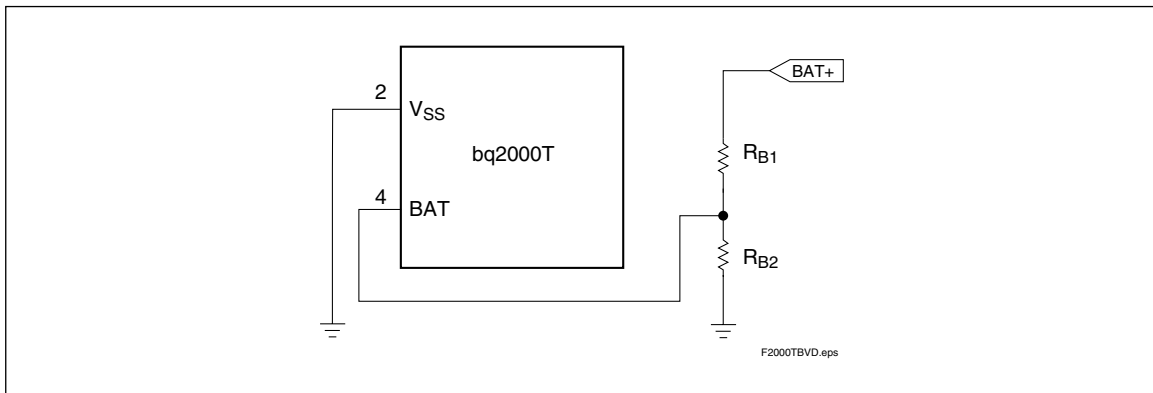

Figure 6. Battery Voltage Divider

programmed value of the maximum charge time divided by 32.

$$\text{hold-off period} = \frac{\text{maximum time - out}}{32}$$

## Top-Off and Pulse-Trickle Charge

An optional top-off charge is available for NiCd or NiMH batteries. Top-off may be desirable on batteries that have a tendency to terminate charge before reaching full capacity. To enable this option, the capacitance value of  $C_{MTO}$  connected to pin RC (Figure 4) should be greater than  $0.13\mu\text{F}$ , and the value of the resistor connected to this pin should be less than  $15\text{k}\Omega$ . To disable top-off, the capacitance value should be less than  $0.07\mu\text{F}$ . The tolerance of the capacitor needs to be taken into account in component selection.

Once enabled, the top-off is performed over a period equal to the maximum charge time at a rate of  $\frac{1}{16}$  that of fast charge.

Following top-off, the bq2000T trickle-charges the battery by enabling the MOD to charge at a rate of once every 1.0 second. The trickle pulse-width is user-selectable and is set by the value of the resistor  $R_{MTO}$ , which is on pin RC. Figure 7 shows the relationship between the trickle pulse-width and the value of  $R_{MTO}$ . The typical tolerance of the pulsewidth below  $150\text{k}\Omega$  is  $\pm 10\%$ .

During top-off and trickle-charge, the bq2000T monitors battery voltage and temperature. These functions are suspended if the battery voltage rises above the maximum cell voltage ( $V_{MCV}$ ) or if the temperature exceeds the high-temperature fault threshold ( $V_{HTF}$ ).

## Charge Current Control

The bq2000T controls the charge current through the MOD output pin. The current-control circuit supports a switching-current regulator with frequencies up to  $500\text{kHz}$ . The bq2000T monitors charge current at the SNS input by the voltage drop across a sense-resistor,  $R_{SNS}$ , in series with the battery pack. See Figure 9 for a typical current-sensing circuit.  $R_{SNS}$  is sized to provide the desired fast-charge current ( $I_{MAX}$ ):

$$I_{MAX} = \frac{0.05}{R_{SNS}}$$

If the voltage at the SNS pin is greater than  $V_{SNSLO}$  or less than  $V_{SNSHI}$ , the bq2000T switches the MOD output high to pass charge current to the battery. When the SNS voltage is less than  $V_{SNSLO}$  or greater than  $V_{SNSHI}$ , the bq2000T switches the MOD output low to shut off charging current to the battery. Figure 8 shows a typical multi-chemistry charge circuit.

## Voltage Input

As shown in Figure 6, a resistor voltage-divider between the battery pack's positive terminal and  $V_{SS}$  scales the battery voltage measured at pin BAT.

For Li-Ion battery packs, the resistor values  $R_{B1}$  and  $R_{B2}$  are calculated by the following equation:

$$\frac{R_{B1}}{R_{B2}} = \left( N * \frac{V_{CELL}}{V_{MCV}} \right) - 1$$

where  $N$  is the number of cells in series and  $V_{CELL}$  is the manufacturer-specified charging voltage. The end-to-end input impedance of this resistive divider network should be at least  $200\text{k}\Omega$  and no more than  $1\text{M}\Omega$ .

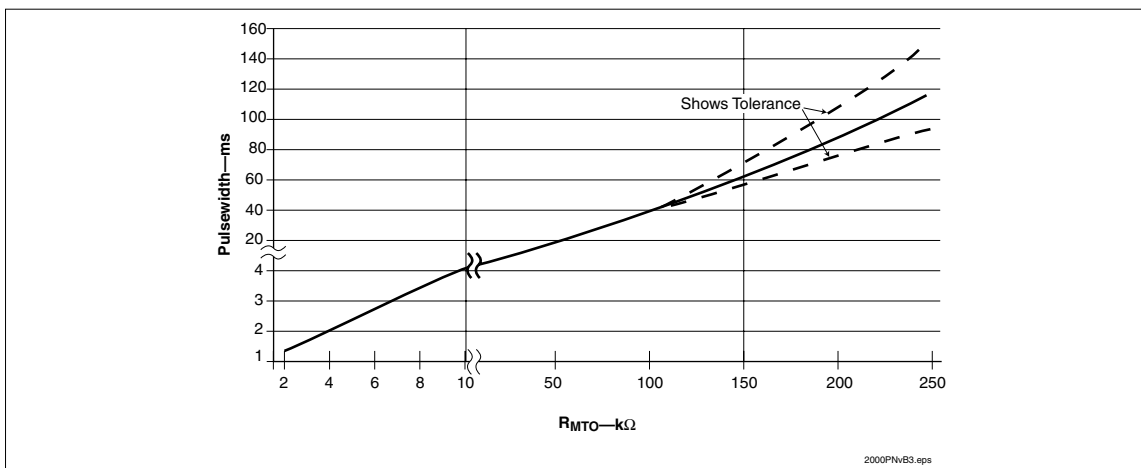

Figure 7. Relationship Between Trickle Pulse-Width and Value of  $R_{MTO}$

# bq2000T

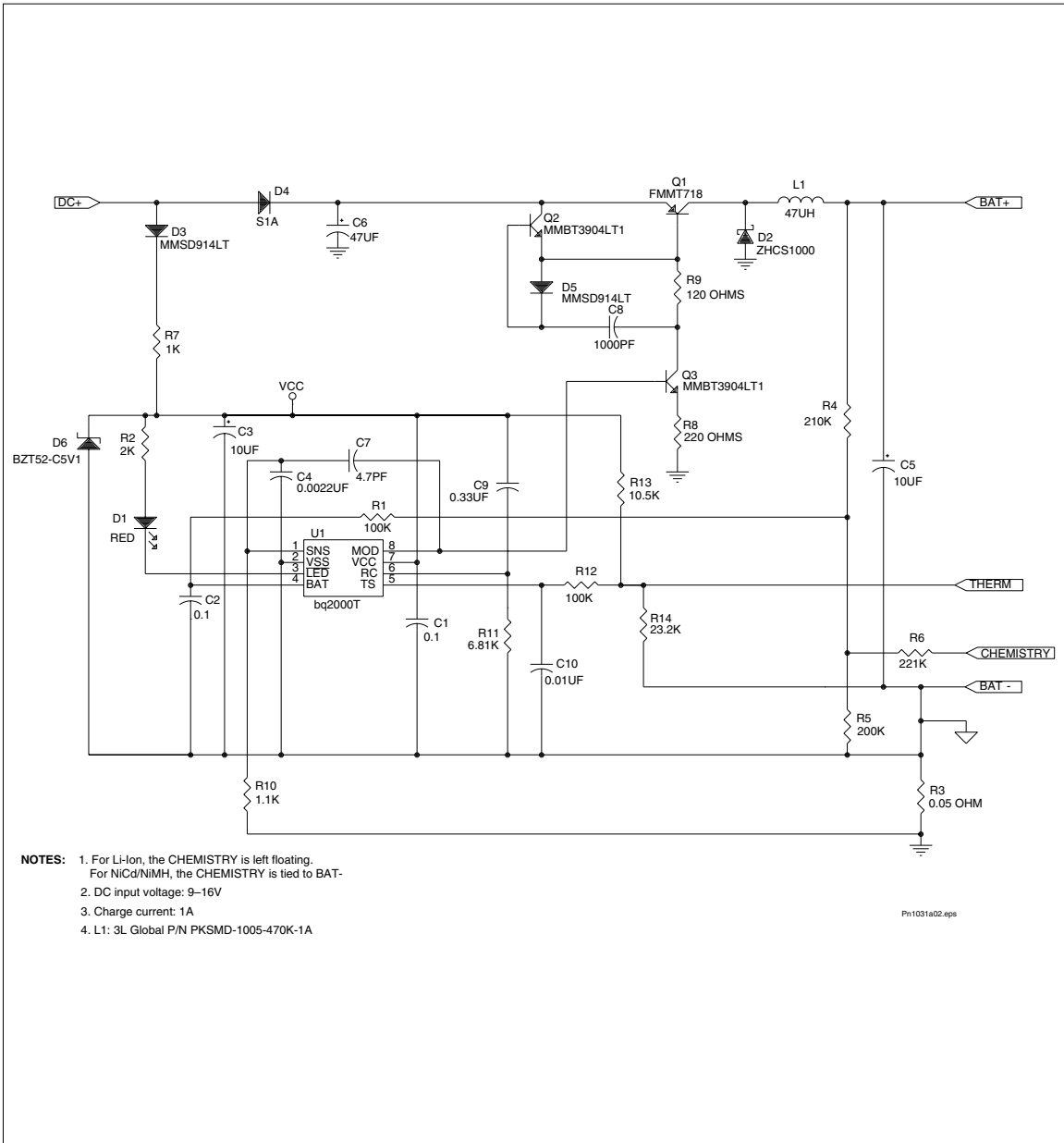

Figure 8. Single-Cell Li-Ion, Three-Cell NiCd/NiMH 1A Charger



**Table 2. Summary of NiCd or NiMH Charging Characteristics**

Parameter	Value
Maximum cell voltage ( $V_{MCV}$ )	2V
Minimum pre-charge qualification voltage ( $V_{LBAT}$ )	950mV
High-temperature cutoff voltage ( $V_{TCO}$ )	$0.225 * V_{CC}$
High-temperature fault voltage ( $V_{HTF}$ )	$0.25 * V_{CC}$
Low-temperature fault voltage ( $V_{LTF}$ )	$0.5 * V_{CC}$
bq2000T fast-charge maximum time out (MTO)	$R_{MTO} * C_{MTO} * 35,988$
Fast-charge charging current ( $I_{MAX}$ )	$0.05/R_{SNS}$
Hold-off period	$MTO/32$
Top-off charging current (optional)	$I_{MAX}/16$
Top-off period (optional)	MTO
Trickle-charge frequency	1Hz
Trickle-charge pulse-width	See Figure 7

A NiCd or NiMH battery pack consisting of N series-cells may benefit by the selection of the  $R_{B1}$  value to be N-1 times larger than the  $R_{B2}$  value.

In a mixed-chemistry design, a common voltage-divider is used as long as the maximum charge voltage of the nickel-based pack is below that of the Li-Ion pack. Otherwise, different scaling is required.

### Temperature Monitoring

The bq2000T measures the temperature by the voltage at the TS pin. This voltage is typically generated by a negative-temperature-coefficient thermistor. The

bq2000T compares this voltage against its internal threshold voltages to determine if charging is safe. These thresholds are the following:

- High-temperature cutoff voltage:  $V_{TCO} = 0.225 * V_{CC}$   
This voltage corresponds to the maximum temperature (TCO) at which fast charging is allowed. The bq2000T terminates fast charge if the voltage on pin TS falls below  $V_{TCO}$ .
- High-temperature fault voltage:  $V_{HTF} = 0.25 * V_{CC}$   
This voltage corresponds to the temperature (HTF) at which fast charging is allowed to begin.
- Low-temperature fault voltage:  $V_{LTF} = 0.5 * V_{CC}$   
This voltage corresponds to the minimum temperature

**Table 3. Summary of Li-Ion Charging Characteristics**

Parameter	Value
Maximum cell voltage ( $V_{MCV}$ )	2V
Minimum pre-charge qualification voltage ( $V_{LBAT}$ )	950mV
High-temperature cutoff voltage ( $V_{TCO}$ )	$0.225 * V_{CC}$
High-temperature fault voltage ( $V_{HTF}$ )	$0.25 * V_{CC}$
Low-temperature fault voltage ( $V_{LTF}$ )	$0.5 * V_{CC}$
bq2000T fast-charge maximum time-out (MTO)	$2 * R_{MTO} * C_{MTO} * 35,988$
Fast-charge charging current ( $I_{MAX}$ )	$0.05/R_{SNS}$
Hold-off period	$MTO/32$
Minimum current (for fast-charge termination)	$I_{MAX}/14$
Trickle-charge frequency (before fast charge only)	1Hz
Trickle-charge pulse-width (before fast charge only)	See Figure 7

## bq2000T

**Table 4. Temperature-Monitoring Conditions**

Temperature	Condition	Action
$V_{TS} > V_{LTF}$	Cold battery—checked at all times	Suspends fast charge or top-off and timer Allows trickle charge—LED flashes at 1Hz rate during pre-charge qualification and fast charge
$V_{HTF} < V_{TS} < V_{LTF}$	Optimal operating range	Allows charging
$V_{TS} < V_{HTF}$	Hot battery—checked during charge qualification and top-off and trickle-charge	Suspends fast-charge initiation, does not allow trickle charge—LED flashes at 1Hz rate during pre-charge qualification
$V_{TS} < V_{TCO}$	Battery exceeding maximum allowable temperature—checked at all times	Terminates fast charge or top-off

(LTF) at which fast charging or top-off is allowed. If the voltage on pin TS rises above  $V_{LTF}$ , the bq2000T suspends fast charge or top-off but does not terminate charge. When the voltage falls back below  $V_{LTF}$ , fast charge or top-off resumes from the point where suspended. Trickle-charge is allowed during this condition.

Table 4 summarizes these various conditions.

### Charge Status Display

The charge status is indicated by open-drain output LED. Table 5 summarizes the display output of the bq2000T.

**Table 5. Charge Status Display**

Charge Action State	LED Status
Battery absent	High impedance
Pre-charge qualification	1Hz flash
Trickle charge (before fast charge)	1Hz flash
Fast charging	Low
Top-off or trickle (after fast charge, NiCd, NiMH only)	High impedance
Charge complete	High impedance
Sleep mode	High impedance
Charge suspended ( $V_{TS} > V_{LTF}$ )	1Hz flash

### Sleep Mode

The bq2000T features a sleep mode for low power consumption. This mode is enabled when the voltage at pin BAT is above the low-power-mode threshold,  $V_{SLP}$ . During sleep mode, the bq2000T shuts down all internal circuits, drives the LED output to high-impedance state, and drives pin MOD to low. Restoring BAT below the  $V_{MCV}$  threshold initiates the IC and starts a fast-charge cycle.

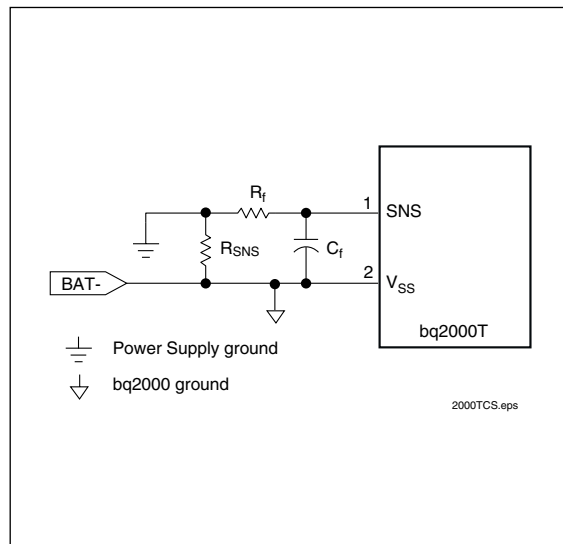

**Figure 9. Current-Sensing Circuit**

## Absolute Maximum Ratings

Symbol	Parameter	Minimum	Maximum	Unit	Notes
V <sub>CC</sub>	V <sub>CC</sub> relative to V <sub>SS</sub>	-0.3	+7.0	V	
V <sub>T</sub>	DC voltage applied on any pin, excluding V <sub>CC</sub> relative to V <sub>SS</sub>	-0.3	+7.0	V	
T <sub>OPR</sub>	Operating ambient temperature	-20	+70	°C	
T <sub>STG</sub>	Storage temperature	-40	+125	°C	
T <sub>SOLDER</sub>	Soldering temperature	-	+260	°C	10s max.

**Note:** Permanent device damage may occur if Absolute Maximum Ratings are exceeded. Functional operation should be limited to the Recommended DC Operating Conditions detailed in this data sheet. Exposure to conditions beyond the operational limits for extended periods of time may affect device reliability.

## DC Thresholds (T<sub>A</sub> = T<sub>OPR</sub>; V<sub>CC</sub> = 5V ±20% unless otherwise specified)

Symbol	Parameter	Rating	Tolerance	Unit	Notes
V <sub>TCO</sub>	Temperature cutoff	0.225 * V <sub>CC</sub>	±5%	V	Voltage at pin TS
V <sub>HTE</sub>	High-temperature fault	0.25 * V <sub>CC</sub>	±5%	V	Voltage at pin TS
V <sub>LTF</sub>	Low-temperature fault	0.5 * V <sub>CC</sub>	±5%	V	Voltage at pin TS
V <sub>MCV</sub>	Maximum cell voltage	2.00	±0.75%	V	V <sub>BAT</sub> > V <sub>MCV</sub> inhibits fast charge
V <sub>LBAT</sub>	Minimum cell voltage	950	±5%	mV	Voltage at pin BAT
V <sub>THERM</sub>	TS input change for ΔT/Δt detection	$-\frac{V_{CC}}{161}$	±25%	V/Min	
V <sub>SNSHI</sub>	High threshold at SNS, resulting in MOD-low	50	±10	mV	Voltage at pin SNS
V <sub>SNSLO</sub>	Low threshold at SNS, resulting in MOD-high	-50	±10	mV	Voltage at pin SNS
V <sub>SLP</sub>	Sleep-mode input threshold	V <sub>CC</sub> - 1	±0.5	V	Applied to pin BAT
V <sub>RCH</sub>	Recharge threshold	V <sub>MCV</sub> - 0.1	±0.02	V	At pin BAT

## bq2000T

### Recommended DC Operating Conditions (TA = TOPR)

Symbol	Condition	Minimum	Typical	Maximum	Unit	Notes
V <sub>CC</sub>	Supply voltage	4.0	5.0	6.0	V	
I <sub>CC</sub>	Supply current	-	0.5	1	mA	Exclusive of external loads
I <sub>CCS</sub>	Sleep current	-	-	5	μA	V <sub>BAT</sub> = V <sub>SLP</sub>
V <sub>TS</sub>	Thermistor input	0.5	-	V <sub>CC</sub>	V	V <sub>TS</sub> < 0.5V prohibited
V <sub>OH</sub>	Output high	V <sub>CC</sub> - 0.2	-	-	V	MOD, I <sub>OH</sub> = 20mA
V <sub>OL</sub>	Output low	-	-	0.2	V	MOD, LED, I <sub>OL</sub> = 20mA
I <sub>OZ</sub>	High-impedance leakage current	-	-	5	μA	LED
I <sub>snk</sub>	Sink current	-	-	20	mA	MOD, LED
R <sub>MTO</sub>	Charge timer resistor	2	-	250	kΩ	
C <sub>MTO</sub>	Charge timer capacitor	0.001	-	1.0	μF	

**Note:** All voltages relative to V<sub>SS</sub> except as noted.

### Impedance

Symbol	Parameter	Minimum	Typical	Maximum	Unit
R <sub>BAT</sub>	Battery input impedance	10	-	-	MΩ
R <sub>TS</sub>	TS input impedance	10	-	-	MΩ
R <sub>SNS</sub>	SNS input impedance	10	-	-	MΩ

### Timing (TA = TOPR; V<sub>CC</sub> = 5V ± 20% unless otherwise specified)

Symbol	Parameter	Minimum	Typical	Maximum	Unit
d <sub>MTO</sub>	MTO time-base variation	-5	-	+5	%
f <sub>TRKL</sub>	Pulse-trickle frequency	0.9	1.0	1.1	Hz

## Data Sheet Revision History

Change No.	Page No.	Description	Nature of Change
1	5	Minimum current termination	Was: 14% Is: 7%
1	3	Added state diagram	
1	7	Changed capacitor value for enabling top-off	Was: 0.13 $\mu$ F Is: 0.26 $\mu$ F
1	8	Figure 8	Schematic updated
1	10	V <sub>TCO</sub> , V <sub>HTF</sub> , V <sub>LTF</sub>	Tolerance updated
2	9	Minimum current (for fast charge termination)	Was: I <sub>MAX</sub> /7 Is: I <sub>MAX</sub> /14

**Note:** Change 1 = May 1999 B changes to Final from Jan. 1999 Preliminary data sheet.  
Change 2 = February 2000 changes from May 1999 B.

## Ordering Information

### bq2000T

**Package Option:**

PN = 8-pin narrow plastic DIP  
SN = 8-pin narrow SOIC  
TS = 8-pin TSSOP

**Device:**

bq2000T Multi-Chemistry Fast-Charge IC with  $\Delta T/\Delta t$  Detection

**8-Pin DIP (PN)**

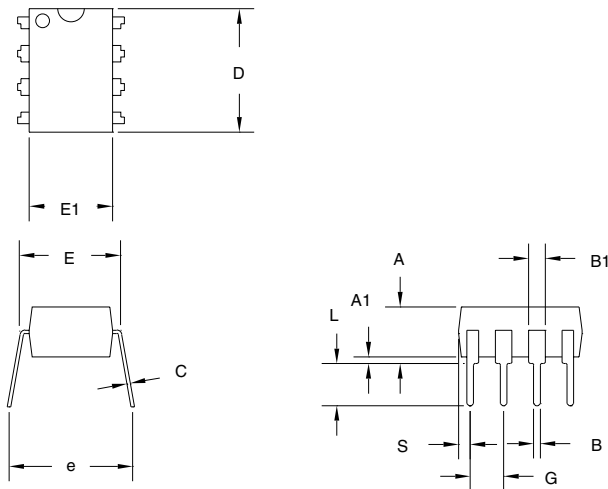

**8-Pin PN (0.300" DIP)**

Dimension	Inches		Millimeters	
	Min.	Max.	Min.	Max.
A	0.160	0.180	4.06	4.57
A1	0.015	0.040	0.38	1.02
B	0.015	0.022	0.38	0.56
B1	0.055	0.065	1.40	1.65
C	0.008	0.013	0.20	0.33
D	0.350	0.380	8.89	9.65
E	0.300	0.325	7.62	8.26
E1	0.230	0.280	5.84	7.11
e	0.300	0.370	7.62	9.40
G	0.090	0.110	2.29	2.79
L	0.115	0.150	2.92	3.81
S	0.020	0.040	0.51	1.02

**8-Pin SOIC Narrow (SN)**

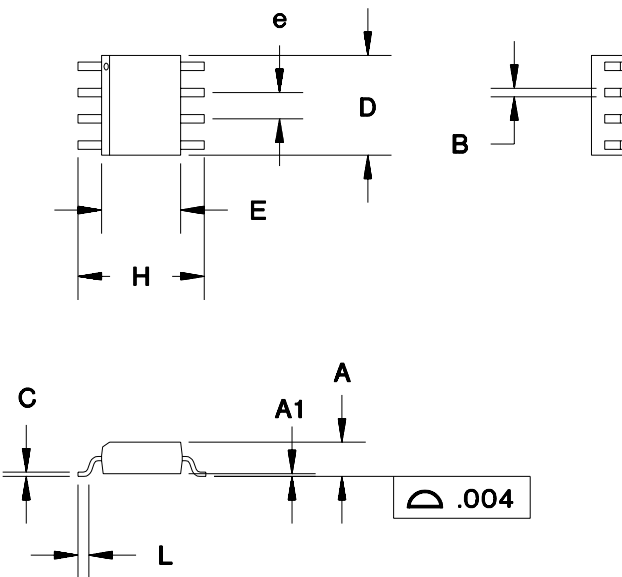

**8-Pin SN (0.150" SOIC)**

Dimension	Inches		Millimeters	
	Min.	Max.	Min.	Max.
A	0.060	0.070	1.52	1.78
A1	0.004	0.010	0.10	0.25
B	0.013	0.020	0.33	0.51
C	0.007	0.010	0.18	0.25
D	0.185	0.200	4.70	5.08
E	0.150	0.160	3.81	4.06
e	0.045	0.055	1.14	1.40
H	0.225	0.245	5.72	6.22
L	0.015	0.035	0.38	0.89

# bq2000T

## 8-Pin TSSOP ~ TS Package Suffix

Dimension	Millimeters		Inches	
	Min.	Max.	Min.	Max.
A	-	1.10	-	0.043
A1	0.05	0.15	0.002	0.006
B	0.18	0.30	0.007	0.012
C	0.09	0.18	0.004	0.007
D	2.90	3.10	0.115	0.122
E	4.30	4.48	0.169	0.176
e	0.65BSC		0.0256BSC	
H	6.25	6.50	0.246	0.256
L	0.50	0.70	0.020	0.028

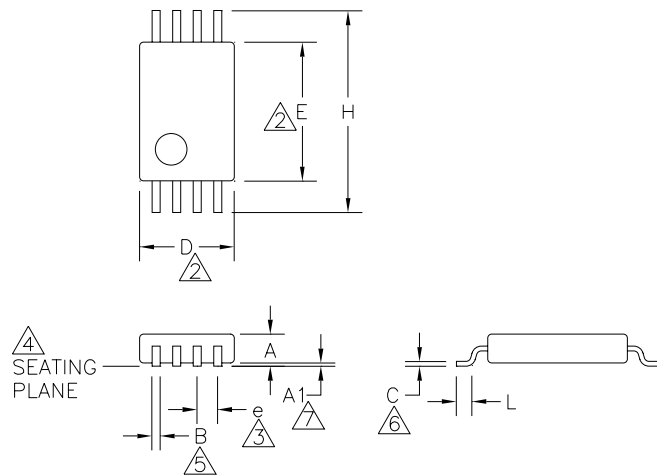

### Notes:

- Controlling dimension: millimeters. Inches shown for reference only.
- 'D' and 'E' do not include mold flash or protrusions. Mold flash or protrusions shall not exceed 0.15mm per side.
- Each lead centerline shall be located within  $\pm 0.10$ mm of its exact true position.
- Leads shall be coplanar within 0.08mm at the seating plane.
- Dimension 'B' does not include dambar protrusion. The dambar protrusion(s) shall not cause the lead width to exceed 'B' maximum by more than 0.08mm.
- Dimension applies to the flat section of the lead between 0.10mm and 0.25mm from the lead tip.
- 'A1' is defined as the distance from the seating plane to the lowest point of the package body (base plane).

### **IMPORTANT NOTICE**

Texas Instruments and its subsidiaries (TI) reserve the right to make changes to their products or to discontinue any product or service without notice, and advise customers to obtain the latest version of relevant information to verify, before placing orders, that information being relied on is current and complete. All products are sold subject to the terms and conditions of sale supplied at the time of order acknowledgement, including those pertaining to warranty, patent infringement, and limitation of liability.

TI warrants performance of its semiconductor products to the specifications applicable at the time of sale in accordance with TI's standard warranty. Testing and other quality control techniques are utilized to the extent TI deems necessary to support this warranty. Specific testing of all parameters of each device is not necessarily performed, except those mandated by government requirements.

**CERTAIN APPLICATIONS USING SEMICONDUCTOR PRODUCTS MAY INVOLVE POTENTIAL RISKS OF DEATH, PERSONAL INJURY, OR SEVERE PROPERTY OR ENVIRONMENTAL DAMAGE ("CRITICAL APPLICATIONS"). TI SEMICONDUCTOR PRODUCTS ARE NOT DESIGNED, AUTHORIZED, OR WARRANTED TO BE SUITABLE FOR USE IN LIFE-SUPPORT DEVICES OR SYSTEMS OR OTHER CRITICAL APPLICATIONS. INCLUSION OF TI PRODUCTS IN SUCH APPLICATIONS IS UNDERSTOOD TO BE FULLY AT THE CUSTOMER'S RISK.**

In order to minimize risks associated with the customer's applications, adequate design and operating safeguards must be provided by the customer to minimize inherent or procedural hazards.

TI assumes no liability for applications assistance or customer product design. TI does not warrant or represent that any license, either express or implied, is granted under any patent right, copyright, mask work right, or other intellectual property right of TI covering or relating to any combination, machine, or process in which such semiconductor products or services might be or are used. TI's publication of information regarding any third party's products or services does not constitute TI's approval, warranty or endorsement thereof.