



BR2500W - BR2510W

SILICON BRIDGE RECTIFIERS

PRV : 50 - 1000 Volts
Io : 25 Amperes

FEATURES :

- * High current capability
- * High surge current capability
- * High reliability
- * Low reverse current
- * Low forward voltage drop
- * High case dielectric strength

MECHANICAL DATA :

- * Case : Molded plastic with heatsink integrally mounted in the bridge encapsulation
- * Epoxy : UL94V-O rate flame retardant
- * Terminals : Plated lead solderable per MIL-STD-202, Method 208 guaranteed
- * Polarity : Polarity symbols marked on case
- * Mounting position : Bolt down on heat-sink with silicone thermal compound between bridge and mounting surface for maximum heat transfer efficiency
- * Weight : 15.95 grams

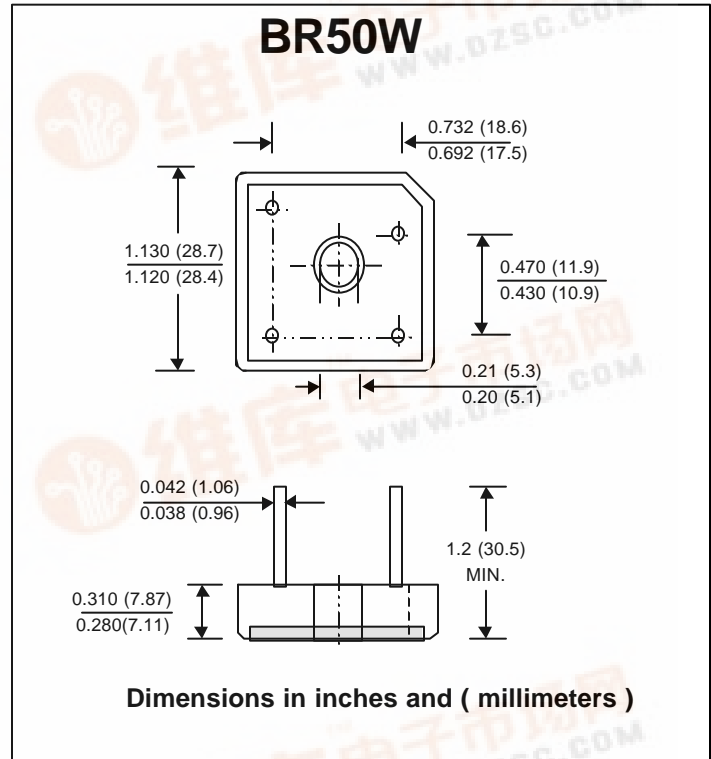

MAXIMUM RATINGS AND ELECTRICAL CHARACTERISTICS

Rating at 25 °C ambient temperature unless otherwise specified.
 Single phase, half wave, 60 Hz, resistive or inductive load.
 For capacitive load, derate current by 20%.

RATING	SYMBOL	BR 2500W	BR 2501W	BR 2502W	BR 2504W	BR 2506W	BR 2508W	BR 2510W	UNIT
Maximum Recurrent Peak Reverse Voltage	V_{RRM}	50	100	200	400	600	800	1000	Volts
Maximum RMS Voltage	V_{RMS}	35	70	140	280	420	560	700	Volts
Maximum DC Blocking Voltage	V_{DC}	50	100	200	400	600	800	1000	Volts
Maximum Average Forward Current $T_c = 55^\circ C$	$I_{F(AV)}$	25							Amp.
Peak Forward Surge Current Single half sine wave Superimposed on rated load (JEDEC Method)	I_{FSM}	300							Amp.
Current Squared Time at $t < 8.3$ ms.	I^2t	375							A^2S
Maximum Forward Voltage per Diode at 12.5 Amp.	V_F	1.1							Volts
Maximum DC Reverse Current $T_a = 25^\circ C$	I_R	10							μA
at Rated DC Blocking Voltage $T_a = 100^\circ C$	$I_{R(H)}$	1.0							mA
Typical Thermal Resistance at Junction to Case (Note 1)	$R_{\theta JC}$	2							$^\circ C/W$
Typical Thermal Resistance at Junction to Ambient	$R_{\theta JA}$	22							$^\circ C/W$
Operating Junction Temperature Range	T_J	- 40 to + 150							$^\circ C$
Storage Temperature Range	T_{STG}	- 40 to + 150							$^\circ C$

Notes : 1) Thermal resistance from Junction to Case with units mounted on a 5" x 4" x 3" (12.7 x 10.2 x 7.3 cm) Al.-wing plate.



RATING AND CHARACTERISTIC CURVES (BR2500W - BR2510W)

FIG.1 - DERATING CURVE FOR OUTPUT RECTIFIED CURRENT

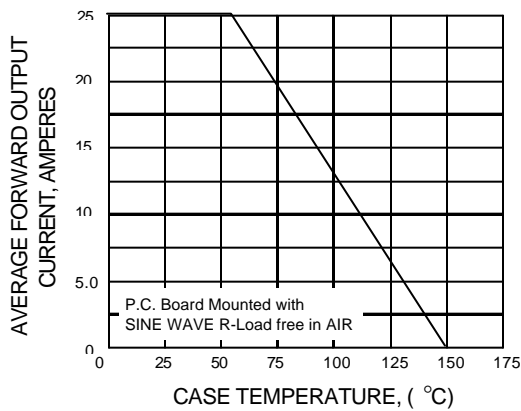

FIG.2 - MAXIMUM NON-REPETITIVE PEAK FORWARD SURGE CURRENT

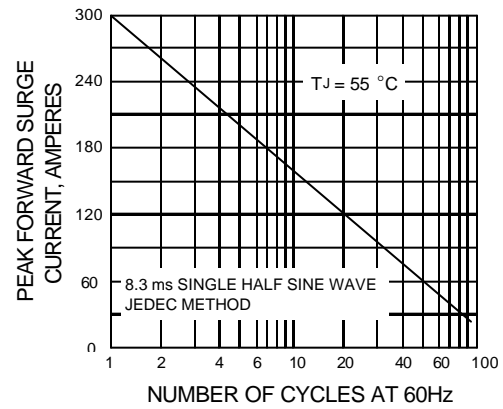

FIG.3 - TYPICAL FORWARD CHARACTERISTICS

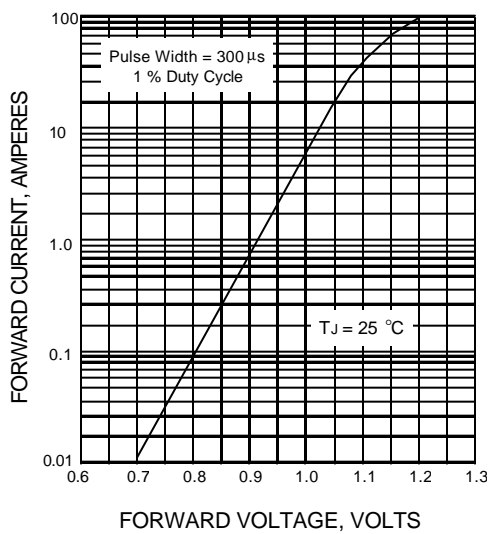

FIG.4 - TYPICAL REVERSE CHARACTERISTICS

