



Correlated Double Sampler (CDS)

AD9823

FEATURES

- 40 MHz correlated double sampler (CDS)
- Fixed 3.5 dB CDS gain
- Low noise optical black clamp circuit
- 3 V single-supply operation
- 14-lead TSSOP package

APPLICATIONS

- Digital still cameras
- Digital video camcorders
- CCTV cameras
- PC cameras
- Portable CCD imaging devices

FUNCTIONAL BLOCK DIAGRAM

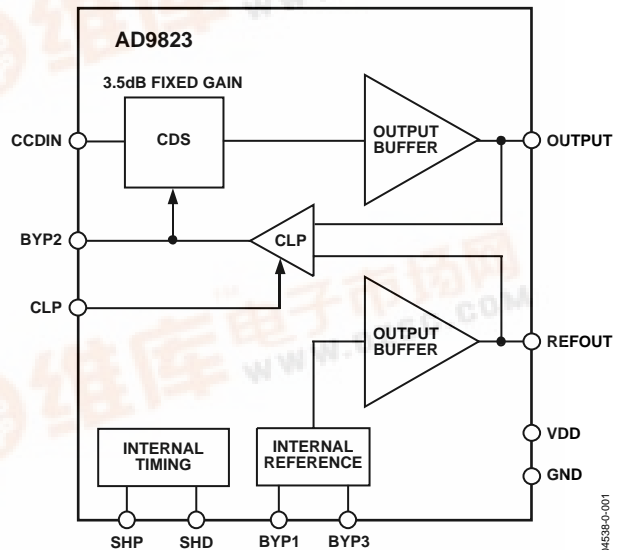

Figure 1. Functional Block Diagram

PRODUCT DESCRIPTION

The AD9823 is a correlated double sampler for digital camera applications. It features a 40 MHz CDS amplifier with 3.5 dB of fixed gain, an internal voltage reference supply, and timing control for the SHP and SHD sampling clocks. Output buffers are also included, providing drive strength for PCB traces and direct connection to an image signal processor such as the AD9821.

The AD9823 is ideal for applications that need to place the CDS and VGA/ADC circuits on separate PC boards. The "pseudo differential" outputs of the AD9823 provide good signal integrity when interfaced with the differential input AD9821.

The AD9823 operates from a single 3 V power supply, typically dissipates 50 mW, and is packaged in a 14-lead TSSOP package.

TABLE OF CONTENTS

Specifications.....	3	Thermal Characteristics	5
General Specifications	3	ESD Caution.....	5
Analog Specifications.....	3	Pin Configuration and Function Descriptions.....	6
Digital Specifications	3	SHP and SHD Timing	6
Timing Specifications	4	Outline Dimensions	8
Absolute Maximum Ratings.....	5	Ordering Guide	8

REVISION HISTORY

Revision 0: Initial Version

SPECIFICATIONS

GENERAL SPECIFICATIONS

Table 1.

Parameter	Min	Typ	Max	Unit
Temperature Range				
Operating	-25		+85	°C
Storage	-65		+150	°C
Power Supply Voltage	2.7		3.6	V
Power Consumption: $f_{\text{SAMP}} = 40 \text{ MHz}$, $V_{\text{DD}} = 3.0 \text{ V}$		50		mW
Maximum Clock Rate	40			MHz
Minimum Clock Rate		5		MHz

ANALOG SPECIFICATIONS

Table 2. T_{MIN} to T_{MAX} , $V_{\text{DD}} = 3.0 \text{ V}$, $f_{\text{SAMP}} = 40 \text{ MHz}$, unless otherwise noted.

Parameter	Min	Typ	Max	Unit	Notes
Analog Input (CCDIN)					
Max Input Range Before Saturation ¹		850		mV p-p	
Allowable CCD Reset Transient ¹		500		mV	
Max CCD Black Pixel Amplitude ¹		100		mV	
Gain	2.5	3.5	4.5	dB	
Nonlinearity, 500 mV Input		1.0		%	Max deviation from ideal straight line
Input Referred Noise		100		$\mu\text{V rms}$	Output noise divided by 3.5 dB gain
Clamp Time Constant		190		μsec	0.1 μF BYP2 capacitor (proportional to capacitor value)
Analog Outputs					
Typical Data Out Signal Range	0.5		1.5	V	0.5 V corresponds to black level
REFOUT Voltage Level		0.5		V	Fixed dc reference for signal output

¹ Input signal characteristics defined as follows:

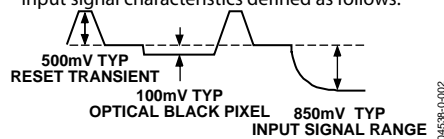

All specifications subject to change without notice.

DIGITAL SPECIFICATIONS

Table 3.

Parameter	Symbol	Min	Typ	Max	Unit
Logic Inputs (SHP, SHD, CLP)					
High Level Input Voltage	V_{IH}	2.1			V
Low Level Input Voltage	V_{IL}			0.6	V
High Level Input Current	I_{IH}		10		μA
Low Level Input Current	I_{IL}		10		μA
Input Capacitance	C_{IN}		10		pF

AD9823

TIMING SPECIFICATIONS

Table 4. T_{MIN} to T_{MAX} , $VDD = 3.0\text{ V}$, $f_{SAMP} = 40\text{ MHz}$, unless otherwise noted.

Parameter (See Figure 3)	Symbol	Min	Typ	Max	Unit
Sample Clocks					
SHP, SHD Clock Period	t_{CP}	25			ns
SHP Pulse Width	t_{SHP}	5	6.25		ns
SHD Pulse Width	t_{SHD}	5	6.25		ns
CLP Pulse Width ¹	t_{COB}	4	10		pixels
SHP Rising Edge to SHD Rising Edge	t_{S1}	12.0	12.5		ns
SHD Rising Edge to SHP Rising Edge	t_{S2}	12.0	12.5		ns
Internal Clock Delay	t_{ID}		3.0		ns
Recommended Data CLK Timing (for AD9821)	t_{REC}		4.5		ns

¹ Minimum CLP pulse width is for functional operation only. Wider typical pulses are recommended to achieve low noise clamp performance. Specifications subject to change without notice.

ABSOLUTE MAXIMUM RATINGS

Table 5.

Parameter	With Respect To	Min	Max	Unit
VDD	GND	-0.3	3.9	V
SHP, SHD	GND	-0.3	VDD + 0.3	V
BYP1, BYP2, BYP3	GND	-0.3	VDD + 0.3	V
CCDIN	GND	-0.3	VDD + 0.3	V
DATAOUT, REFOUT	GND	-0.3	VDD + 0.3	V
CLP	GND	-0.3	VDD + 0.3	V
Junction Temperature			150	°C
Lead Temperature (10 sec)			350	°C

THERMAL CHARACTERISTICS

Thermal Resistance

14-Pin, TSSOP Package

$\theta_{JA} = 89.2^{\circ}\text{C}/\text{W}$

ESD CAUTION

ESD (electrostatic discharge) sensitive device. Electrostatic charges as high as 4000 V readily accumulate on the human body and test equipment and can discharge without detection. Although this product features proprietary ESD protection circuitry, permanent damage may occur on devices subjected to high energy electrostatic discharges. Therefore, proper ESD precautions are recommended to avoid performance degradation or loss of functionality.



AD9823

PIN CONFIGURATION AND FUNCTION DESCRIPTIONS

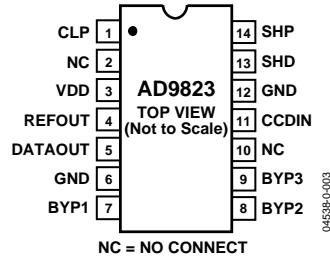

Figure 2. Pin Configurations

Table 6. Pin Function Descriptions

Pin Number	Name	Type ¹	Description
1	CLP	DI	Input Clamp Clock Input (active low, not latched internally).
2	NC	NC	No connection should be connected to GND or VDD.
3	VDD	P	Analog Supply.
4	REFOUT	AO	Output Reference Level.
5	DATAOUT	AO	Output Data Signal.
6	GND	P	Analog Ground.
7	BYP1	AO	Internal Bias Level Decoupling.
8	BYP2	AO	Internal Bias Level Decoupling.
9	BYP3	AO	Internal Bias Level Decoupling.
10	NC	NC	No connection should be connected to GND or VDD.
11	CCDIN	AI	CCD Input.
12	GND	P	Analog Ground.
13	SHD	DI	CDS Sampling Clock Input (For CCD Data Level).
14	SHP	DI	CDS Sampling Clock Input (For CCD Ref Level).

¹AI = Analog Input, AO = Analog Output, DI = Digital Input, DO = Digital Output, P = Power, NC = No Connect.

SHP AND SHD TIMING

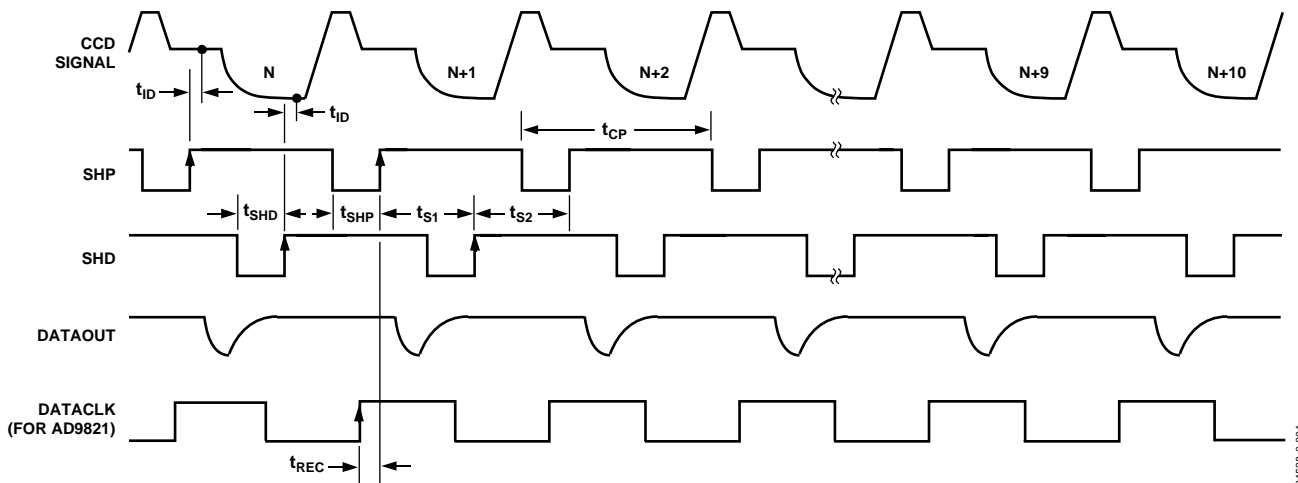

Figure 3. SHP and SHD Timing

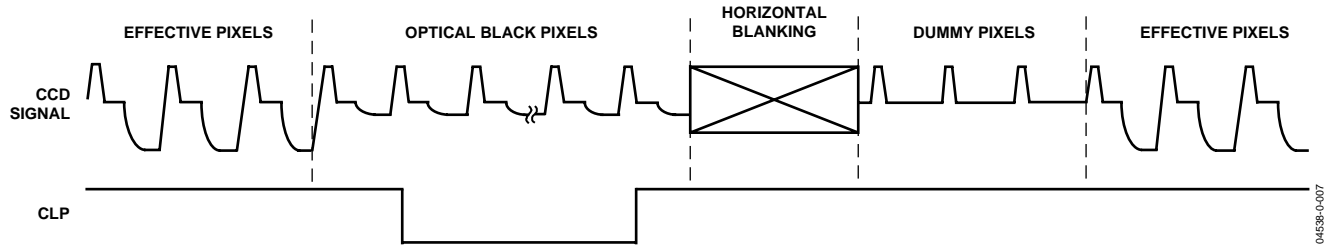

Figure 4. CLP Timing

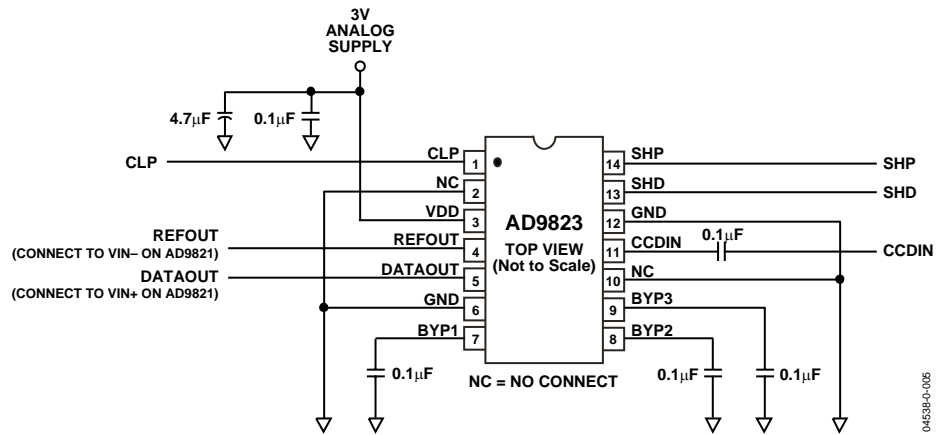

Figure 5. AD9823 Circuit Configuration

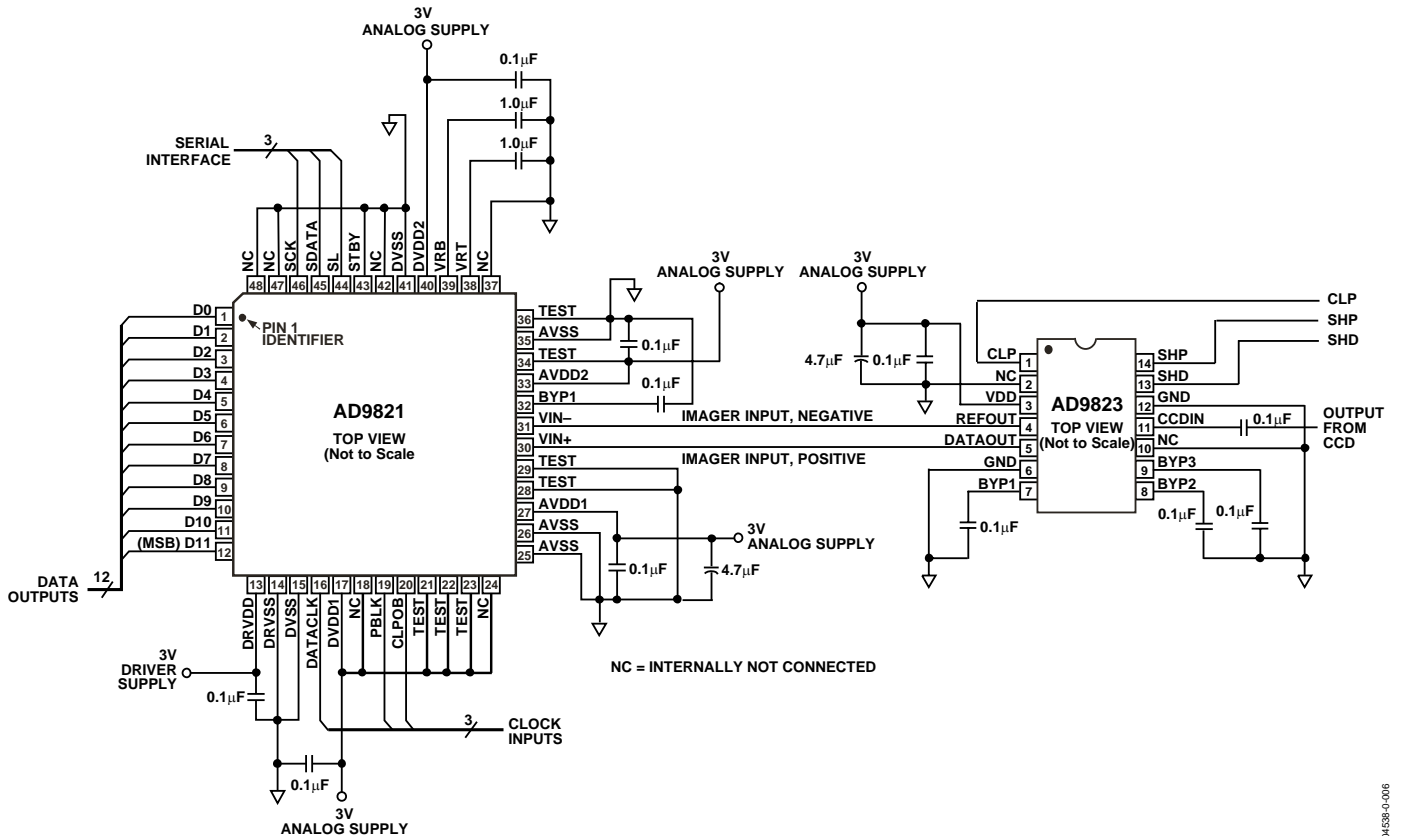

Figure 6. Circuit Configuration with the AD9821 12-Bit Image Signal Processor

AD9823

OUTLINE DIMENSIONS

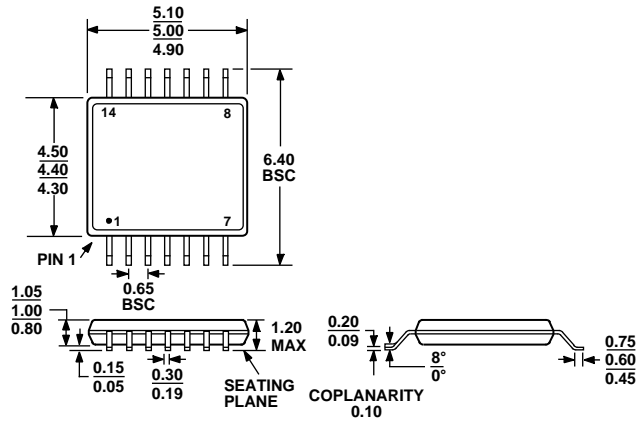

Figure 7. 14-Lead Thin Shrink Small Outline Package [TSSOP]

(RU-14)

Dimensions shown in millimeters

ORDERING GUIDE

Model	Temperature Range	Package Description	Package Option
AD9823BRUZ ¹	-25°C to +85°C	TSSOP	RU-14

¹Z = Pb-free part.