

PWM Power Unit

The device allows continuous power control for lamps, LEDs or inductive loads.

- Highside switch
- Overtemperature protection
- Short circuit / overload protection through pulse width reduction and overload shutdown
- Load dump protection
- Undervoltage and overvoltage shutdown with auto-restart and hysteresis
- Reverse battery protection 1)
- Timing frequency adjustable
- Controlled switching rise and fall times
- Maximum current internally limited
- Protection against loss of GND 2)
- Electrostatic discharge (ESD) protection
- Package: TO220/7 and TO220/7 E3128 (SMD), Pin 4 is shorted to the mounting flange

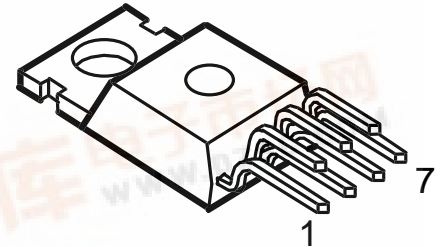

Standard

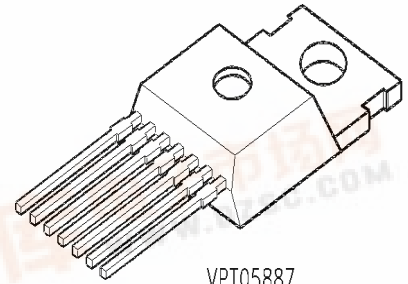

Note: Switching frequency is programmed with an external capacitor.

Type	Ordering Code	Marking	Package
BTS630 (Standard)	Q67060-S6305-A2	-	TO220/7
BTS630	Q67060-S6305-A3	-	TO220/7, E3230

Maximum Ratings

Parameter	Symbol	Values	Unit
Active overvoltage protection	$V_{bb(AZ)}$	>40	V
Short circuit current	I_{SC}	self-limited	-
Input current (DC)	I_{Ct}	2	mA
Pin1 (C_t) and pin19 (V_C)	I_{Vc}	2	mA
Operating temperature range	T_j	-40...+150	°C
Storage temperature range	T_{stg}	-50...+150	
Power dissipation $T_a=25^\circ\text{C}$	P_{tot}	75	W
Thermal resistance chip-case	$R_{th JC}$	≤ 1.67	K/W
chip-ambient	$R_{th JA}$	≤ 75	

1) With 150Ω resistor in signal GND connection.

2) Potential between signal GND and load GND >0.5V

Block Diagram

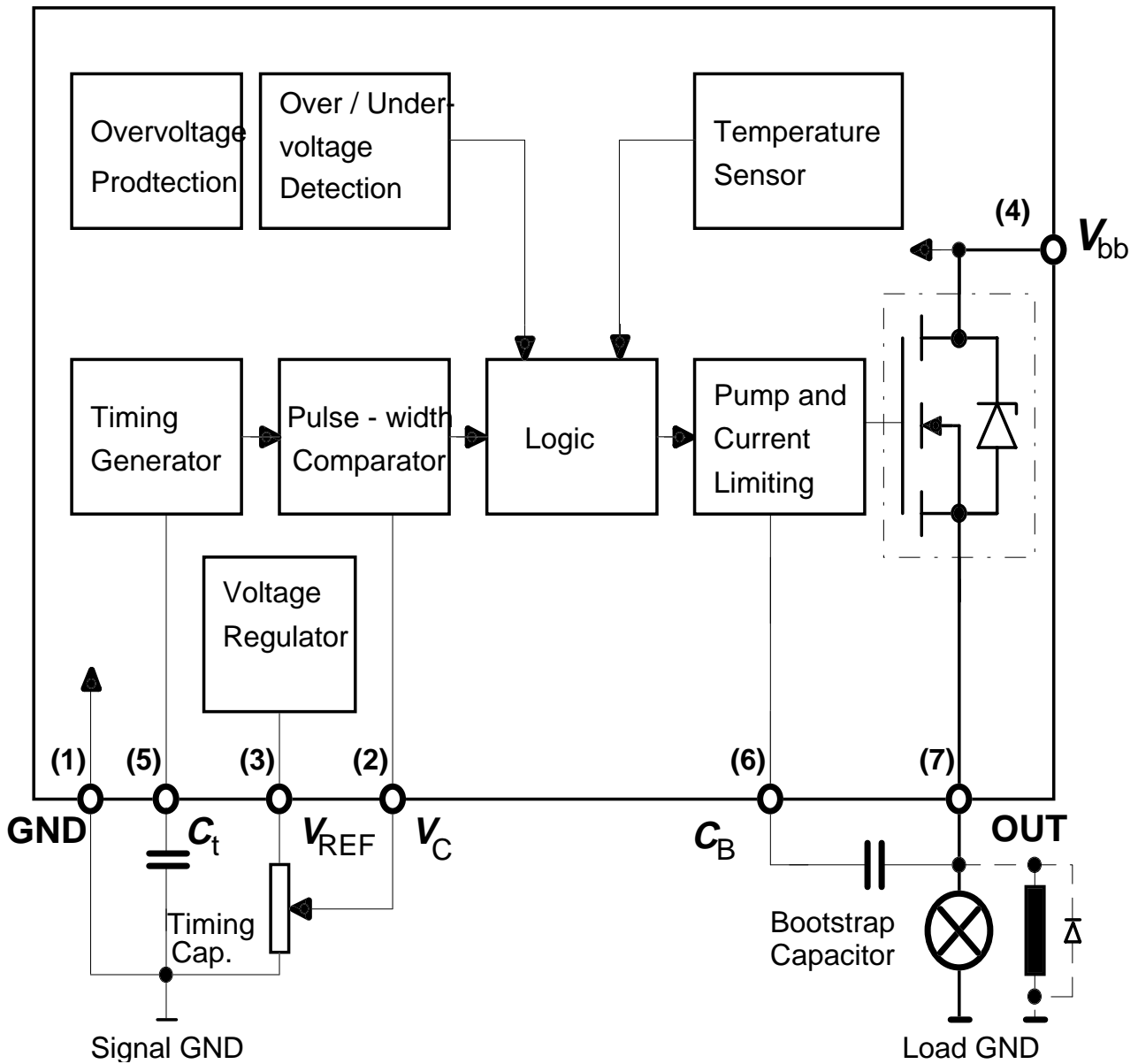

Pin Definitions and Funktionen

Pin	Symbol	Funktionen
1	GND	Ground
2	V_C	Voltage for PWM-Control
3	V_{REF}	Reference Voltage
4	V_{bb}	Supply voltage
5	C_t	Timing capacitor for frequency
6	C_B	Bootstrap capacitor
7	OUT	Output

Pin Configuration (top view)

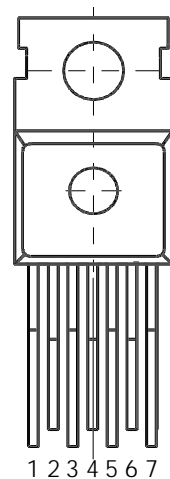

Electrical Characteristics

at $T_j = 25\text{ °C}$, unless otherwise specified. $C_{\text{Bootstrap}} = 22\text{ nF}$

Parameter	Symbol	Values			Unit
		min.	typ.	max.	
On-state resistance $I_L = 3\text{ A}$, $V_{\text{bb}} = 12\text{ V}$	R_{ON}	-	-	70	$\text{m}\Omega$
Operating voltage $T_j = -40 \dots +150\text{ °C}$	V_{bb}	5.9 ¹⁾		16.9 ²⁾	V
Nominal current, calculated value ISO-standard: $V_{\text{bb}} - V_{\text{OUT}} \leq 0.5\text{ V}$, $T_c = 85\text{ °C}$	$I_L\text{-ISO}$	5.8	-	-	A
Load current limit $V_{\text{bb}} - V_{\text{OUT}} > 1\text{ V}$	I_{LLim}	-	20	-	A
Undervoltage shutdown $I_L = 3\text{ A}$	$V_{\text{bb(LOW)}}$	3	4.2	5.4	V
Overvoltage shutdown $I_L = 3\text{ A}$	$V_{\text{bb(HI)}}$	17	18	19	V
Max. output voltage (RMS) $I_L = 3\text{ A}$, $V_{\text{bb}} > 12\text{ V}$	V_{RMSmax}	12	-	14	V
Reference voltage $I_{\text{REF}} = 10\text{ mA}$	V_{REF}	2		3	V
Reference current pin 18 (GND) to pin 20 (V_{REF}) short	I_{REF}	-	150	-	mA
Internal current consumption during operation, measured in PWM gap	I_{R}	-		5	mA
Bootstrap voltage, pin 2 (C_{B1}) to pin 3 (C_{B2}) $V_{\text{bb}} = 12\text{ V}$,	V_{B}	-	10	-	V
PWM frequency $T_c = -40 \dots +150\text{ °C}$, $C_t = 68\text{ nF}$	f_{PWM}	50	-	100	Hz
Max. pulse duty factor $I_L = 3\text{ A}$, $V_{\text{C}} = 0\text{ V}$, (50% V_{OUT})	D_{imax}	95	98	-	%
Min. pulse duty factor $I_L = 3\text{ A}$, $V_{\text{C}} = 0\text{ V}$, (50% V_{OUT})	D_{imin}	-	8	14	%
Slew rate "on" 10 ... 90% I_{OUT}	$du/dt_{\text{(on)}}$	20	-	120	$\text{mV}/\mu\text{s}$
Slew rate "off" 90 ... 10% I_{OUT}	$du/dt_{\text{(off)}}$	20	-	120	$\text{mV}/\mu\text{s}$
Thermal overload trip temperature	T_j	150	-	-	°C

1) **Note:** undervoltage shutdown

2) **Note:** overvoltage shutdown

Circuits

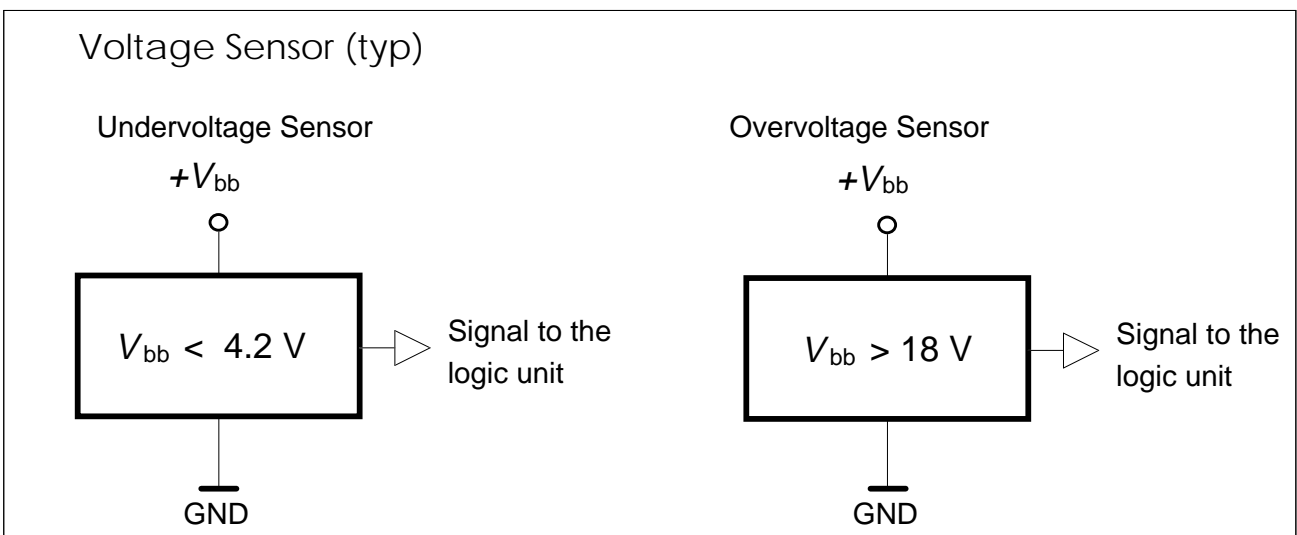
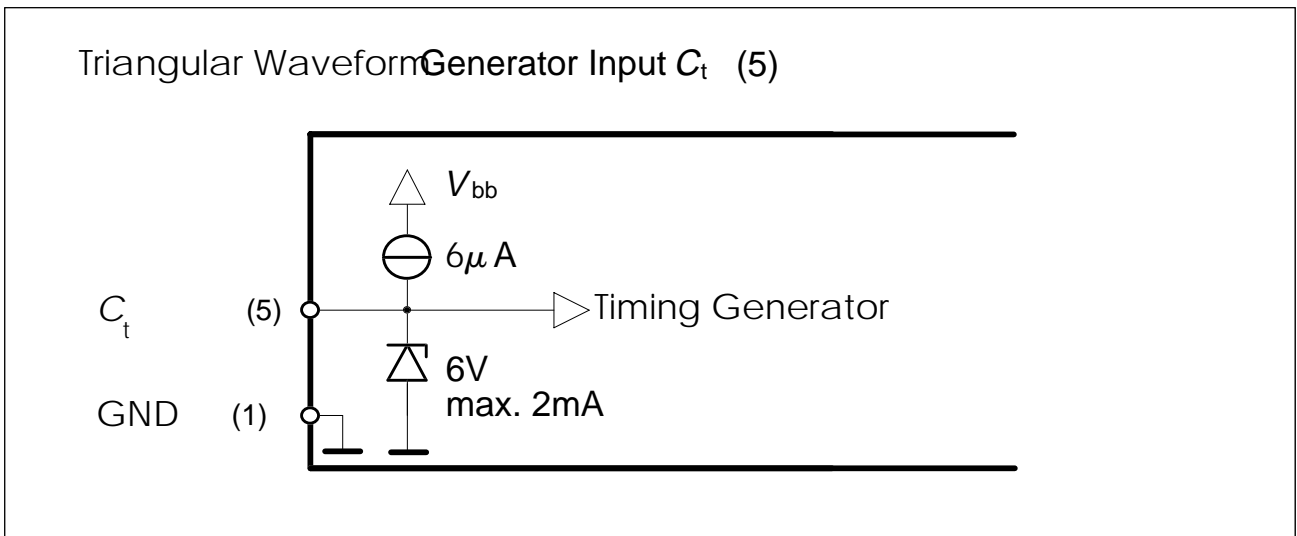
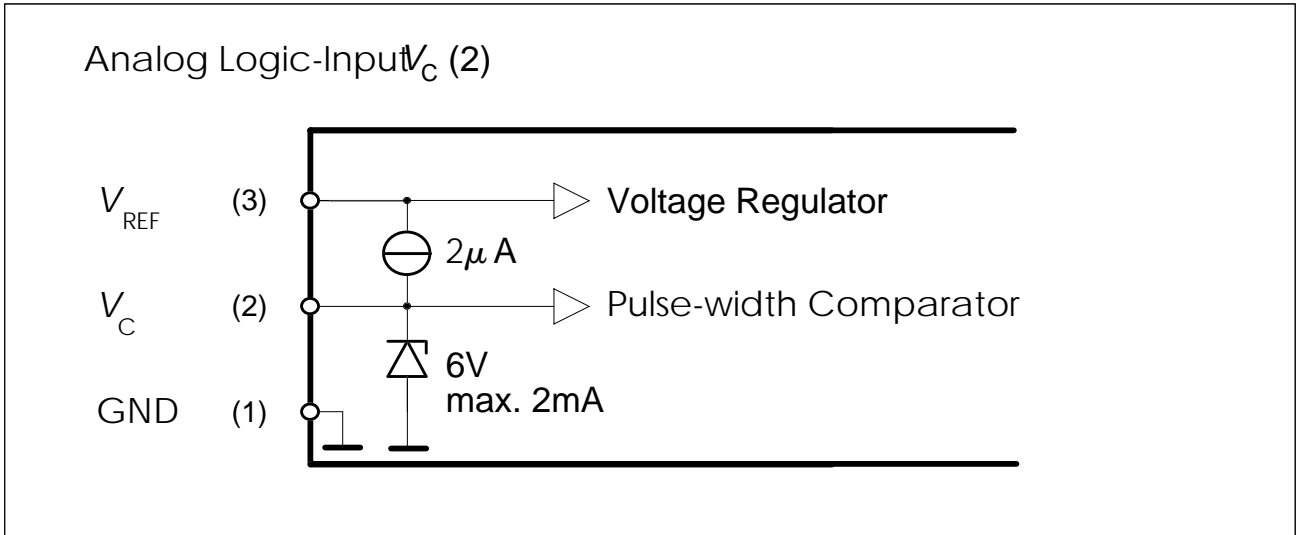

Package Outline TO220/7

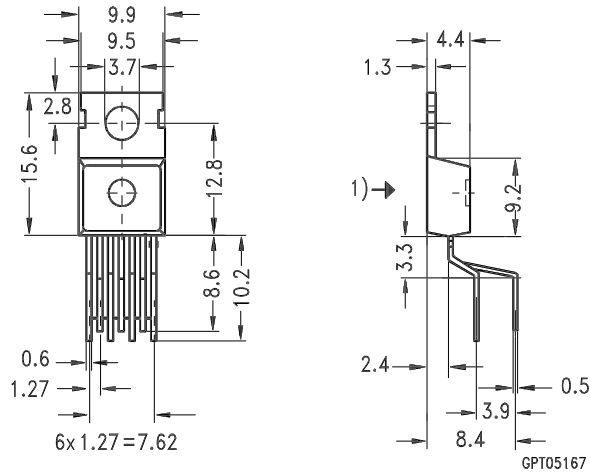

1) shear and punch direction no burrs this surface

Dimensions in mm

Package Outline TO220/7 E3230

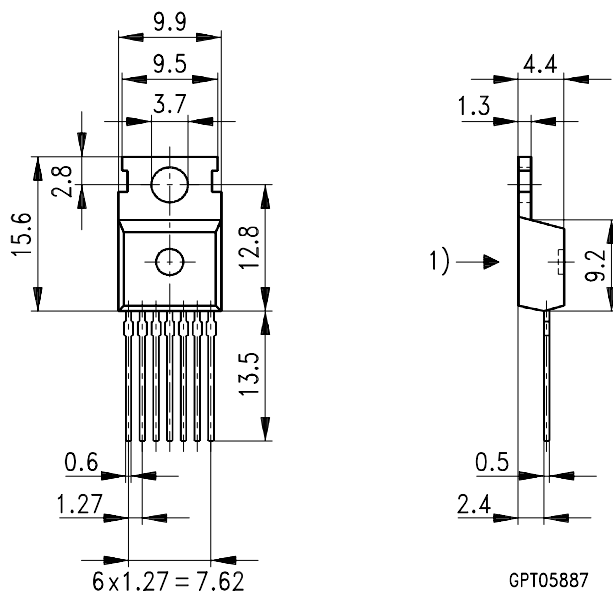

1) Shear and punch direction no burrs this surface

Dimensions in mm

Application Note

