



BU208D BU508D/BU508DFI

HIGH VOLTAGE FAST-SWITCHING NPN POWER TRANSISTORS

- BU208D AND BU508DFI ARE STM PREFERRED SALESTYPES
- HIGH VOLTAGE CAPABILITY
- U.L. RECOGNISED ISOWATT218 PACKAGE (U.L. FILE # E81734 (N))
- JEDEC TO-3 METAL CASE
- NPN TRANSISTOR WITH INTEGRATED FREEWHEELING DIODE

APPLICATIONS:

- HORIZONTAL DEFLECTION FOR COLOUR TV

DESCRIPTION

The BU208D, BU508D and BU508DFI are manufactured using Multi-epitaxial Mesa technology for cost-effective high performance and uses a Hollow Emitter structure to enhance switching speeds.

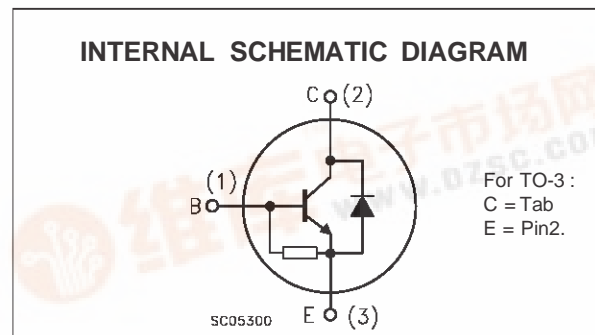
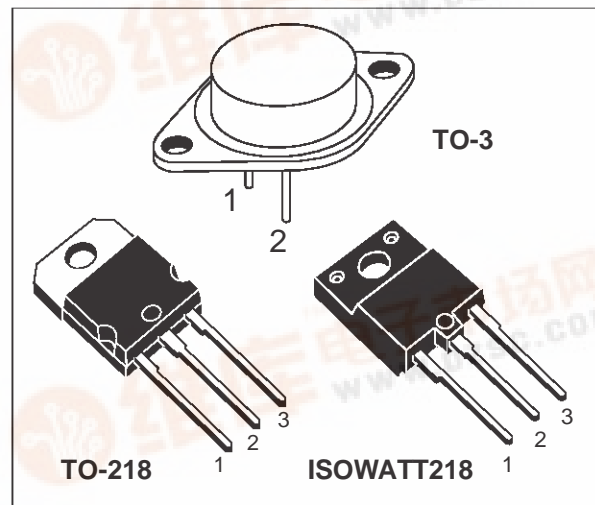

ABSOLUTE MAXIMUM RATINGS

Symbol	Parameter	Value			Unit
V_{CES}	Collector-Emitter Voltage ($V_{BE} = 0$)	1500			V
V_{CEO}	Collector-Emitter Voltage ($I_B = 0$)	700			V
V_{EBO}	Emitter-Base Voltage ($I_C = 0$)	10			V
I_C	Collector Current	8			A
I_{CM}	Collector Peak Current ($t_p < 5$ ms)	15			A
		TO - 3	TO - 218	ISOWATT218	
P_{tot}	Total Dissipation at $T_c = 25$ °C	150	125	50	W
T_{stg}	Storage Temperature	-65 to 175	-65 to 150	-65 to 150	°C
T_j	Max. Operating Junction Temperature	175	150	150	°C

BU208D / BU508D / BU508DFI

THERMAL DATA

			TO-3	TO-218	ISOWATT218	
R _{thj-case}	Thermal Resistance Junction-case	Max	1	1	2.5	°C/W

ELECTRICAL CHARACTERISTICS (T_{case} = 25 °C unless otherwise specified)

Symbol	Parameter	Test Conditions	Min.	Typ.	Max.	Unit
I _{CES}	Collector Cut-off Current (V _{BE} = 0)	V _{CE} = 1500 V V _{CE} = 1500 V T _j = 125 °C			1 2	mA mA
I _{EBO}	Emitter Cut-off Current (I _C = 0)	V _{EB} = 5 V			300	mA
V _{CEO(sus)}	Collector-Emitter Sustaining Voltage	I _C = 100 m A	700			V
V _{CE(sat)*}	Collector-Emitter Saturation Voltage	I _C = 4.5 A I _B = 2 A			1	V
V _{BE(sat)*}	Base-Emitter Saturation Voltage	I _C = 4.5 A I _B = 2 A			1.3	V
t _s t _f	INDUCTIVE LOAD Storage Time Fall Time	I _C = 4.5 A h _{FE} = 2.5 V _{CC} = 140 V L _C = 0.9 mH L _B = 3 μH		7 550		ms ns
V _F	Diode Forward Voltage	I _F = 4 A			2	V
f _T	Transition Frequency	I _C = 0.1 A V _{CE} = 5 V f = 5 MHz		7		MHz

* Pulsed: Pulse duration = 300 μs, duty cycle 1.5 %

Safe Operating Area (TO-3)

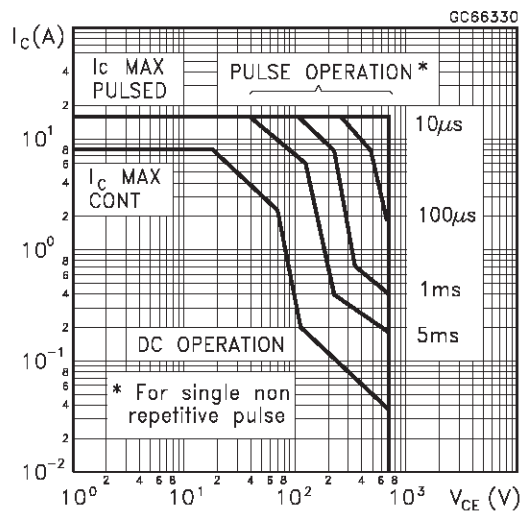

Safe Operating Area (TO-218/ISOWATT218)

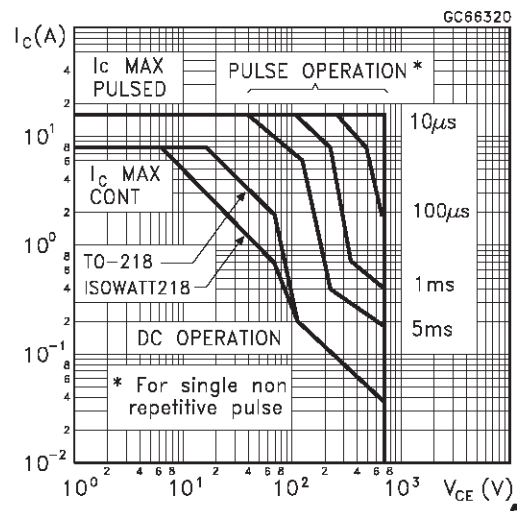

DC Current Gain

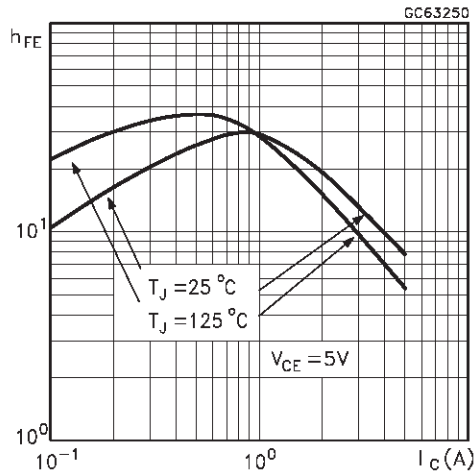

Collector Emitter Saturation Voltage

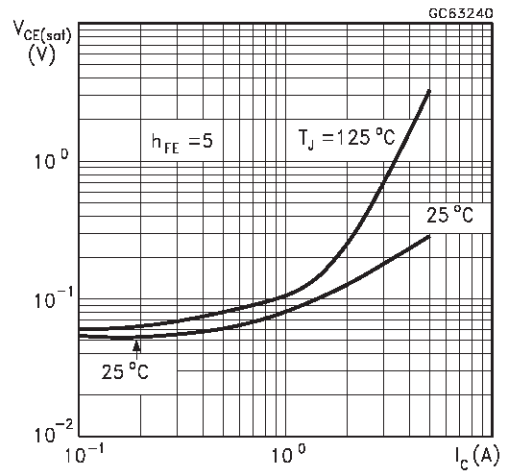

Base Emitter Saturation Voltage

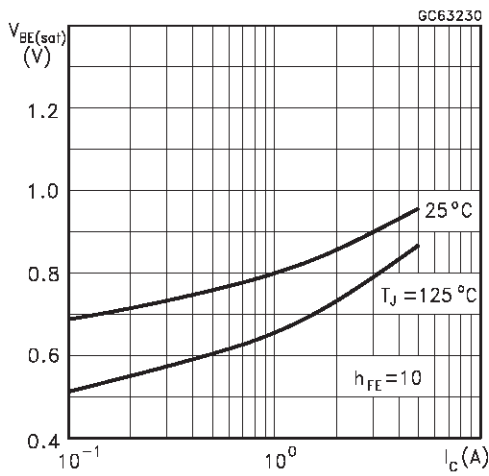

Switching Time Inductive Load

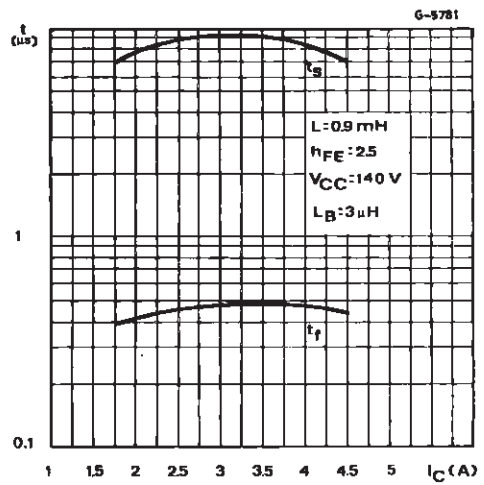

Switching Time Inductive Load (see figure 1)

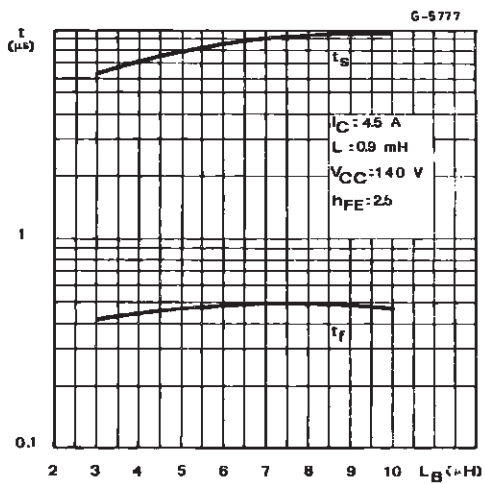

Switching Time Percentance vs. Case

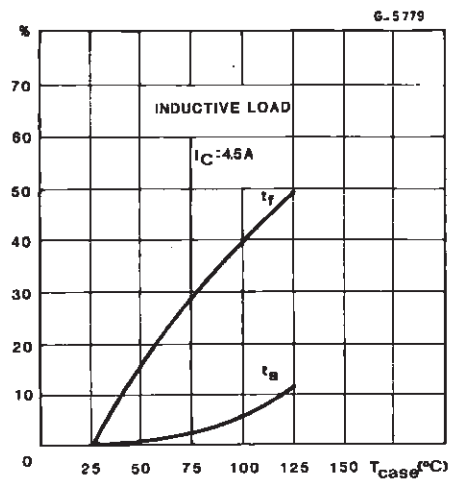
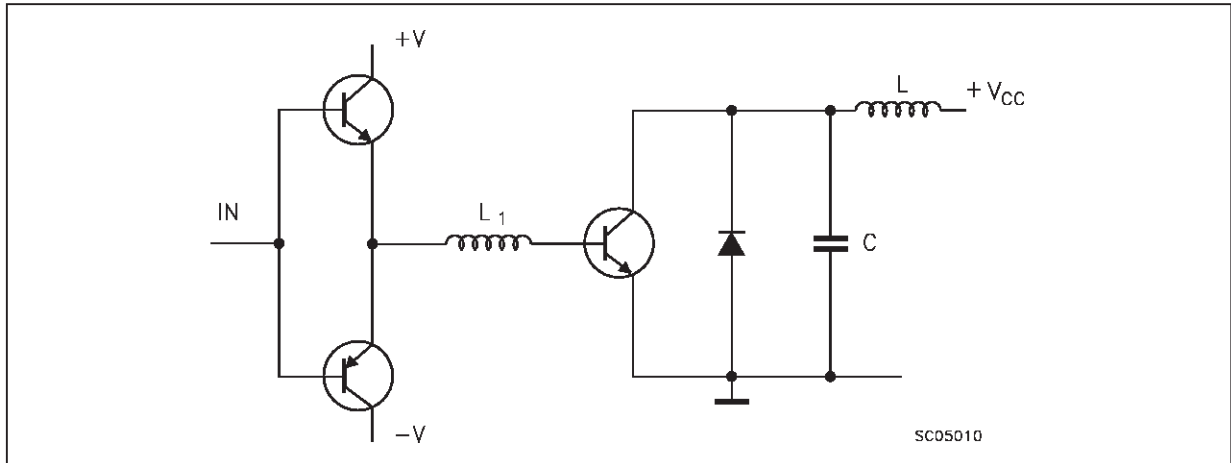
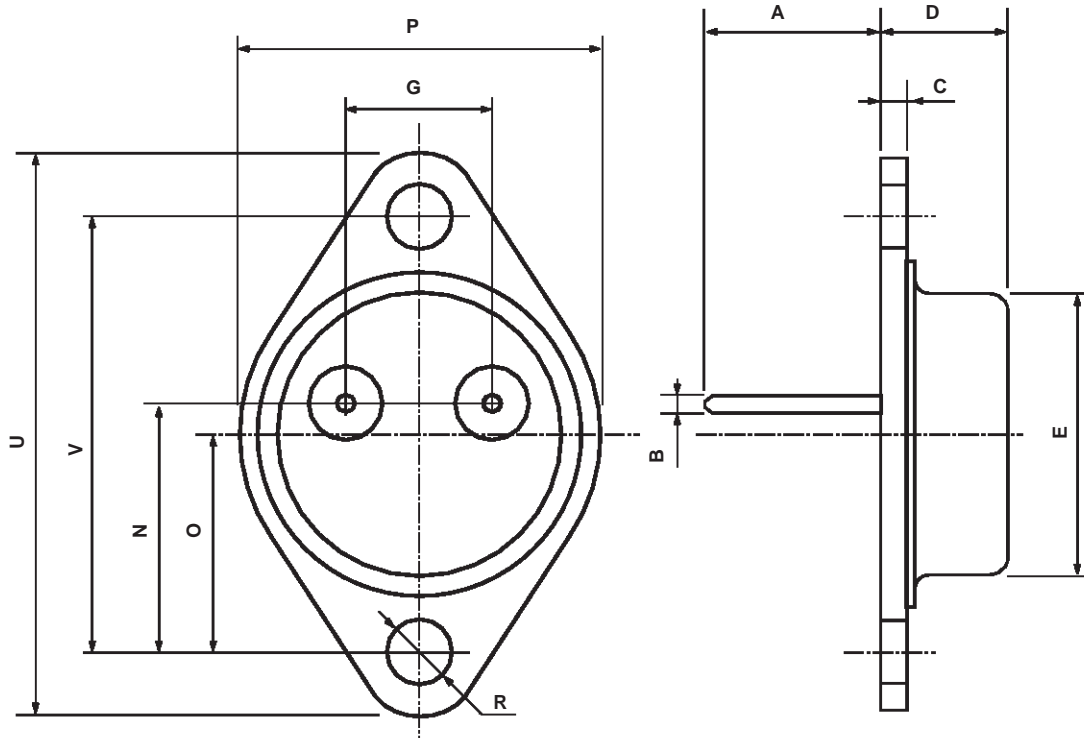

Figure 1: Inductive Load Switching Test Circuit.



TO-3 MECHANICAL DATA

DIM.	mm			inch		
	MIN.	TYP.	MAX.	MIN.	TYP.	MAX.
A	11.00		13.10	0.433		0.516
B	0.97		1.15	0.038		0.045
C	1.50		1.65	0.059		0.065
D	8.32		8.92	0.327		0.351
E	19.00		20.00	0.748		0.787
G	10.70		11.10	0.421		0.437
N	16.50		17.20	0.649		0.677
P	25.00		26.00	0.984		1.023
R	4.00		4.09	0.157		0.161
U	38.50		39.30	1.515		1.547
V	30.00		30.30	1.187		1.193



P003F

TO-218 (SOT-93) MECHANICAL DATA

DIM.	mm			inch		
	MIN.	TYP.	MAX.	MIN.	TYP.	MAX.
A	4.7		4.9	0.185		0.193
C	1.17		1.37	0.046		0.054
D		2.5			0.098	
E	0.5		0.78	0.019		0.030
F	1.1		1.3	0.043		0.051
G	10.8		11.1	0.425		0.437
H	14.7		15.2	0.578		0.598
L2	-		16.2	-		0.637
L3		18			0.708	
L5	3.95		4.15	0.155		0.163
L6		31			1.220	
R	-		12.2	-		0.480
Ø	4		4.1	0.157		0.161

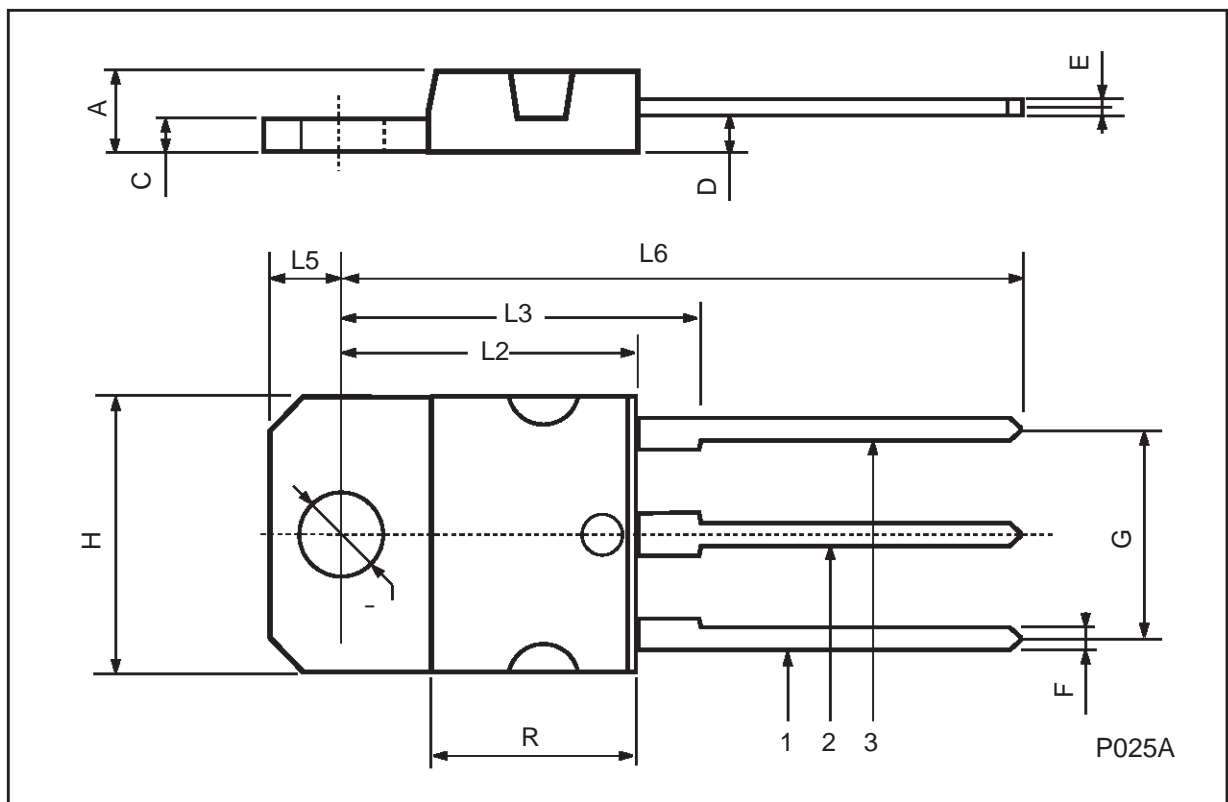

ISOWATT218 MECHANICAL DATA

DIM.	mm			inch		
	MIN.	TYP.	MAX.	MIN.	TYP.	MAX.
A	5.35		5.65	0.210		0.222
C	3.3		3.8	0.130		0.149
D	2.9		3.1	0.114		0.122
D1	1.88		2.08	0.074		0.081
E	0.75		1	0.029		0.039
F	1.05		1.25	0.041		0.049
G	10.8		11.2	0.425		0.441
H	15.8		16.2	0.622		0.637
L1	20.8		21.2	0.818		0.834
L2	19.1		19.9	0.752		0.783
L3	22.8		23.6	0.897		0.929
L4	40.5		42.5	1.594		1.673
L5	4.85		5.25	0.190		0.206
L6	20.25		20.75	0.797		0.817
M	3.5		3.7	0.137		0.145
N	2.1		2.3	0.082		0.090
U		4.6			0.181	

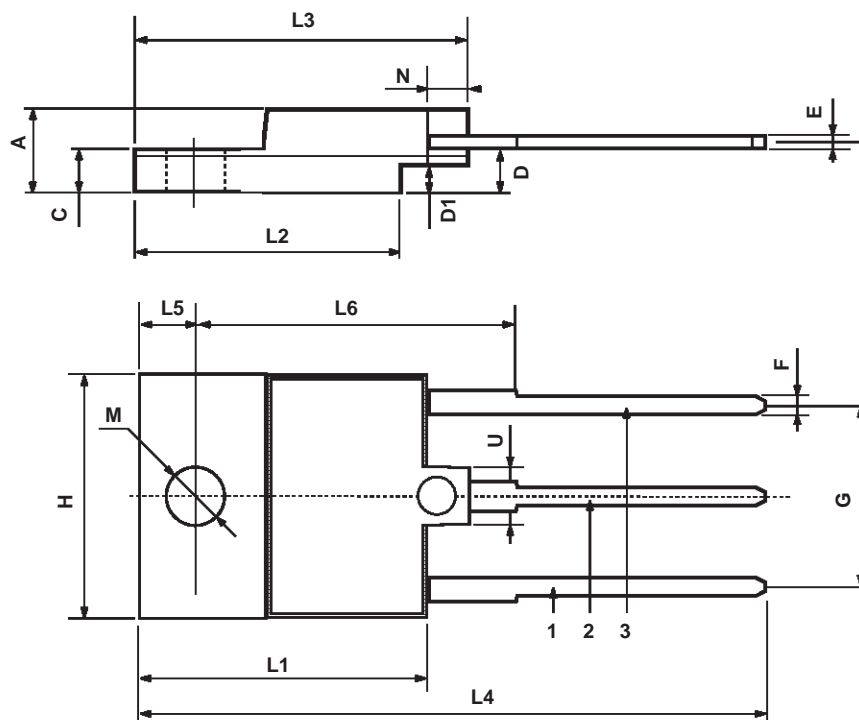

P025C

Information furnished is believed to be accurate and reliable. However, STMicroelectronics assumes no responsibility for the consequences of use of such information nor for any infringement of patents or other rights of third parties which may result from its use. No license is granted by implication or otherwise under any patent or patent rights of STMicroelectronics. Specification mentioned in this publication are subject to change without notice. This publication supersedes and replaces all information previously supplied. STMicroelectronics products are not authorized for use as critical components in life support devices or systems without express written approval of STMicroelectronics.

The ST logo is a trademark of STMicroelectronics

© 1998 STMicroelectronics – Printed in Italy – All Rights Reserved
STMicroelectronics GROUP OF COMPANIES

Australia - Brazil - Canada - China - France - Germany - Italy - Japan - Korea - Malaysia - Malta - Mexico - Morocco - The Netherlands -
Singapore - Spain - Sweden - Switzerland - Taiwan - Thailand - United Kingdom - U.S.A.