

# VCO + phase comparator for TV

## BU2370FV

BU2370FV is a VCO+phase comparator IC used to construct PLL system. Adopting external LPF and divider can generate the PLL system and low jitter clocks. Output can be switched into half.

### ●Applications

TV

### ●Features

- 1) VCO can oscillate output (20MHz to 60MHz)
- 2) High-speed edge trigger type phase comparator
- 3) Can control VCO, and phase comparator independently
- 4) 3.3V signal power supply
- 5) Small SSOP-B14 package

### ●External dimensions (Unit : mm)

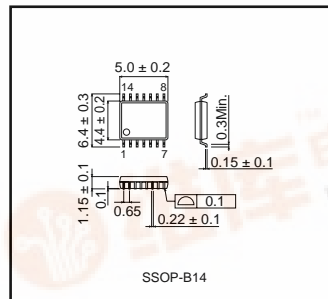

### ●Absolute maximum ratings (Ta=25°C)

Parameter	Symbol	Limits	Unit
Power supply voltage	V <sub>DD</sub>	-0.5 to +7.0	V
Input voltage	V <sub>IN</sub>	-0.5 to V <sub>DD</sub> +0.5	V
Operating temperature range	T <sub>stg</sub>	-30 to +125	°C
Power dissipation	P <sub>d</sub>	350	mW

\*An operation is not guaranteed.

\*Derating : 3.5mW/°C for operation above Ta=25°C.

\*Radiation resistance design is not used.

\*Power dissipation is measured when BU2370FV is placed on the board.

### ●Recommended operating conditions

Parameter	Symbol	Min.	Typ.	Max.	Unit
Power supply voltage	V <sub>DD</sub>	3.15	-	3.45	V
Input H voltage range	V <sub>IH</sub>	0.8V <sub>DD</sub>	-	V <sub>DD</sub>	V
Input L voltage range	V <sub>IL</sub>	0	-	0.2V <sub>DD</sub>	V
Operating temperature	T <sub>opr</sub>	-20	-	70	°C
Output load	C <sub>L</sub>	-	-	15	pF

Multimedia ICs

●Block diagram

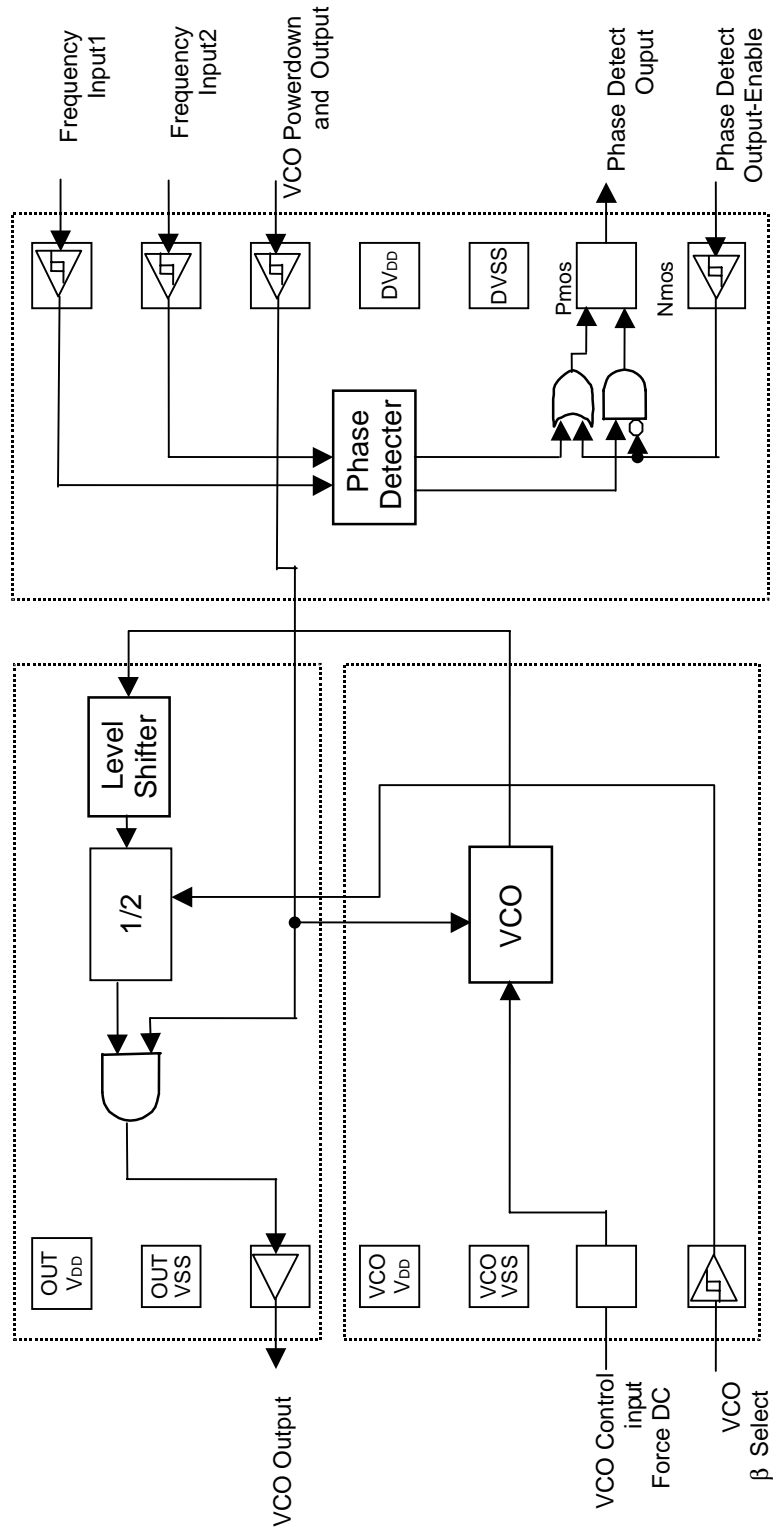

## Multimedia ICs

## ●Pin descriptions

Pin No.	Pin name	Functions
1	Out V <sub>DD</sub>	V <sub>DD</sub> for VCO-OUT
2	Out GND	GND for VCO-OUT
3	VCO OUT	VCO output
4	VCO V <sub>DD</sub>	VCO analog V <sub>DD</sub>
5	VCO GND	VCO analog GND
6	VCO IN	VCO control Pin
7	FSEL1	VCO $\beta$ collect H : 30[MHz/V] L : 15[MHz/V]
8	PDE	PD control pin H : PD Disable (Hi impedance) L : PD Enable
9	PD OUT	PD output
10	DGND	Digital GND for PD
11	DV <sub>DD</sub>	Digital V <sub>DD</sub> for PD
12	VCOE	VCO control Pin H : VCO out Disable ( output L fix) L : VCO out Enable
13	FIN-A	PD input
14	FIN-B	PD input

Multimedia ICs

●Input / output circuits

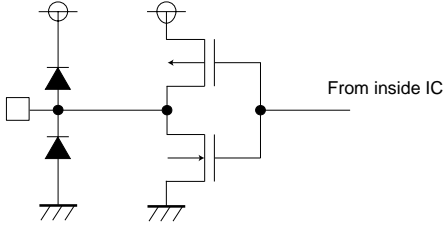
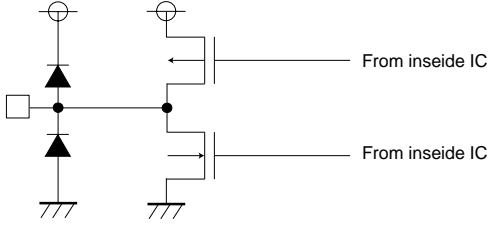
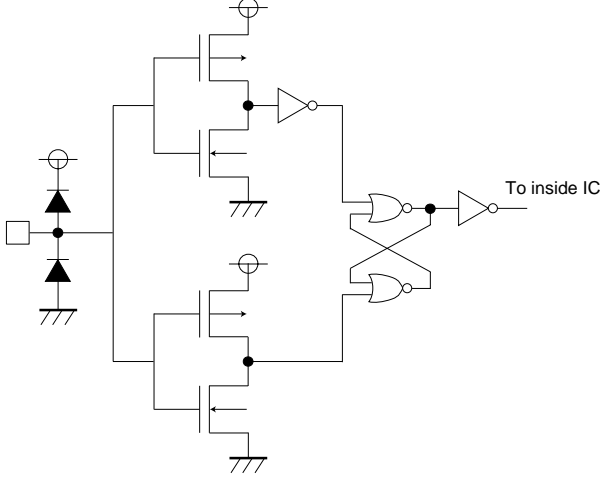
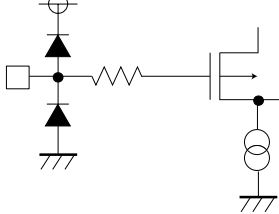
Pin No.	Equivalent circuit
Output PIN (Pin 3)	
Output PIN (Pin 9)	
Input PIN (Schmitt trigger) (Pin 7, 8, 12, 13, 14)	
Input PIN (Pin 6)	

Multimedia ICs

●Electrical characteristics (Unless otherwise noted, Ta=25°C, VCC=3.3V)

Parameter	Symbol	Min.	Typ.	Max.	Unit	Conditions
Operating current consumption	I <sub>DD</sub>	-	20	-	mA	60MHz oscillation when output loaded
VCO						
Input control voltage range (Pin 6)	VID	1	-	3	V	
Input H voltage (Pin 6)	I <sub>IH</sub>	-0.1	0	0.1	μA	Inflow current when V <sub>DD</sub> applied to input
Input L voltage (Pin 6)	I <sub>IL</sub>	-0.1	0	0.1	μA	Outflow current when GND applied to input
Max. oscillation frequency 1	F <sub>MAX1</sub>	30	-	-	MHz	FSEL=L
Max. oscillation frequency 2	F <sub>MAX2</sub>	60	-	-	MHz	FSEL=H
Min. oscillation frequency 1	F <sub>MIN1</sub>	-	-	15	MHz	FSEL=L
Min. oscillation frequency 2	F <sub>MIN2</sub>	-	-	30	MHz	FSEL=H
Frequency sensitivity 1	β <sub>1</sub>	-	15	-	MHz/V	FSEL=L
Frequency sensitivity 2	β <sub>2</sub>	-	30	-	MHz/V	FSEL=H
Output duty	Duty	45	50	55	%	at 1/2 V <sub>DD</sub>
Rise-time	t <sub>r</sub>	-	2.5	-	nsec	Time is from V <sub>DD</sub> 0.2 to V <sub>DD</sub> 0.8
Fall-time	t <sub>f</sub>	-	2.5	-	nsec	Time is from V <sub>DD</sub> 0.2 to V <sub>DD</sub> 0.8

●Application example

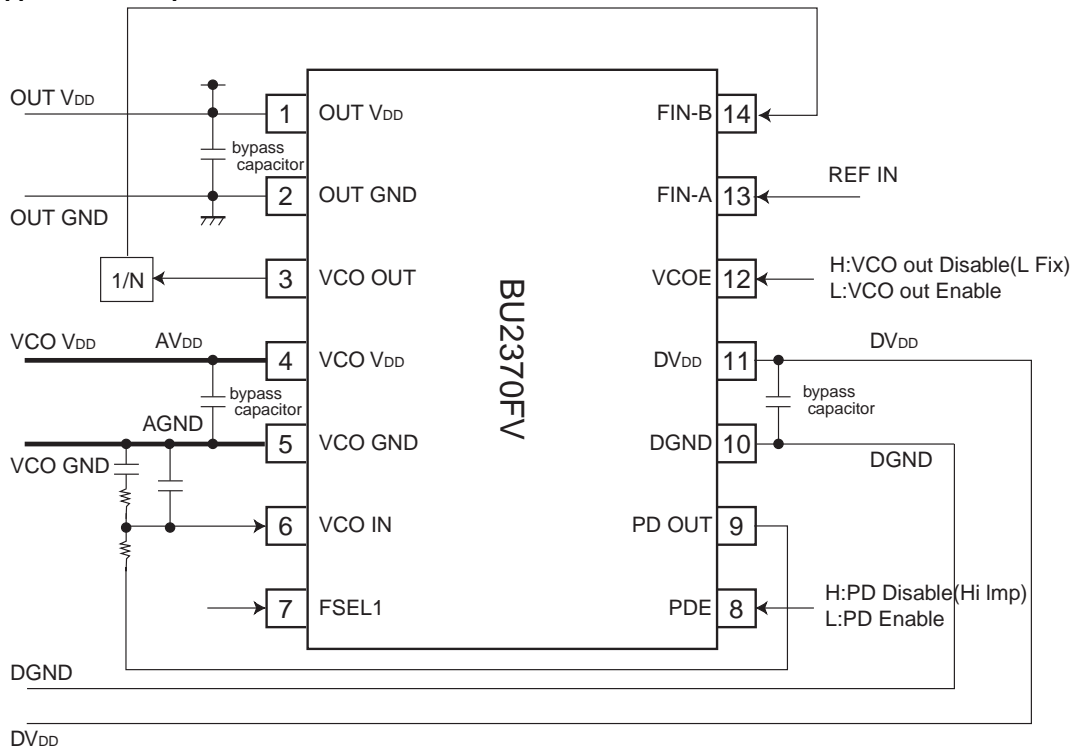

This line is noise source. But if power line and GND are divided into two, this line becoms AV<sub>DD</sub>,AGND

DV<sub>DD</sub>,DGND

OUT DV<sub>DD</sub>,OUT GND

Please take care this Power line. Because this line is most weak indigitalnoise. So this line must be separated from digital\_V<sub>DD</sub>, GND. And place bypass capacitor (0.01μF) for power pin as close to BU2370FV as possible.

And place bypass capacitor (0.01μF) for power pin as close to BU2370FV as possible.

This line is most noise source. So it should be separated from Analog. And this line should be connected V<sub>DD</sub> of external V<sub>CC</sub>-outdivide. And place bypass capacitor (0.01μF) for power pin as close to BU2370FV as possible.

\*Recommend to use capacitor that is better to reduce high frequency noise.

\*Recommend to control (FSEL1, PDE, VCOE) by power line.(DV<sub>DD</sub>, DGND)

### Notes

- No technical content pages of this document may be reproduced in any form or transmitted by any means without prior permission of ROHM CO.,LTD.
- The contents described herein are subject to change without notice. The specifications for the product described in this document are for reference only. Upon actual use, therefore, please request that specifications to be separately delivered.
- Application circuit diagrams and circuit constants contained herein are shown as examples of standard use and operation. Please pay careful attention to the peripheral conditions when designing circuits and deciding upon circuit constants in the set.
- Any data, including, but not limited to application circuit diagrams information, described herein are intended only as illustrations of such devices and not as the specifications for such devices. ROHM CO.,LTD. disclaims any warranty that any use of such devices shall be free from infringement of any third party's intellectual property rights or other proprietary rights, and further, assumes no liability of whatsoever nature in the event of any such infringement, or arising from or connected with or related to the use of such devices.
- Upon the sale of any such devices, other than for buyer's right to use such devices itself, resell or otherwise dispose of the same, no express or implied right or license to practice or commercially exploit any intellectual property rights or other proprietary rights owned or controlled by
- ROHM CO., LTD. is granted to any such buyer.
- Products listed in this document use silicon as a basic material.  
Products listed in this document are no antiradiation design.

The products listed in this document are designed to be used with ordinary electronic equipment or devices (such as audio visual equipment, office-automation equipment, communications devices, electrical appliances and electronic toys).

Should you intend to use these products with equipment or devices which require an extremely high level of reliability and the malfunction of which would directly endanger human life (such as medical instruments, transportation equipment, aerospace machinery, nuclear-reactor controllers, fuel controllers and other safety devices), please be sure to consult with our sales representative in advance.

#### About Export Control Order in Japan

Products described herein are the objects of controlled goods in Annex 1 (Item 16) of Export Trade Control Order in Japan.

In case of export from Japan, please confirm if it applies to "objective" criteria or an "informed" (by MITI clause) on the basis of "catch all controls for Non-Proliferation of Weapons of Mass Destruction.