

BU24591

Optical ICs

4bit 1chip micro-controller for CD-DA

BU24591

The BU24591 is a 4bit 1chip micro-controller for CD-DA that integrates multiple I/O, such as 8bit 8-channel AD converter, pulse width counter, two lines of SIO, and LCD controller driver with 80 segment (Max.). All LCD segment can be switched into CMOS output by the program. These I/O achieves multi-function with few pins.

●Applications

Portable CD-DA, CD radio cassette player

●Features

- 1) Low voltage, high-speed operation
($V_{DD}=2.3$ to $3.6V$ at $4.4MHz$)
- 2) Built-in 8bit 8-channel AD converter
- 3) Built-in pulse width counter
- 4) Built-in two lines of SIO
- 5) Built-in LCD controller driver with 20 segments, 4 common (With 3 common available)
- 6) All segment output of LCD controller driver can be switched into CMOS output by the program.

●Absolute maximum ratings (Ta=25°C)

Parameter	Symbol	Limits	Unit
Applied voltage	V_{DD}	-0.3 to +4.5	V
Power dissipation	P_d	500 *	mW
Operating temperature range	T_{opr}	-25 to +75	°C
Storage temperature range	T_{stg}	-55 to +125	°C

* Reduced by 5mW for each increase in Ta of 1°C over 25°C.

●Recommended operating conditions (Ta=25°C)

Parameter	Symbol	Min.	Typ.	Max.	Unit
Power supply voltage	V_{DD}	2.3	-	3.6	V
Input "H" voltage	V_{IHS}	$0.75V_{DD}$	-	V_{DD}	V
Input "L" voltage	V_{ILS}	0	-	$0.15V_{DD}$	V

Optical ICs

●Block diagram

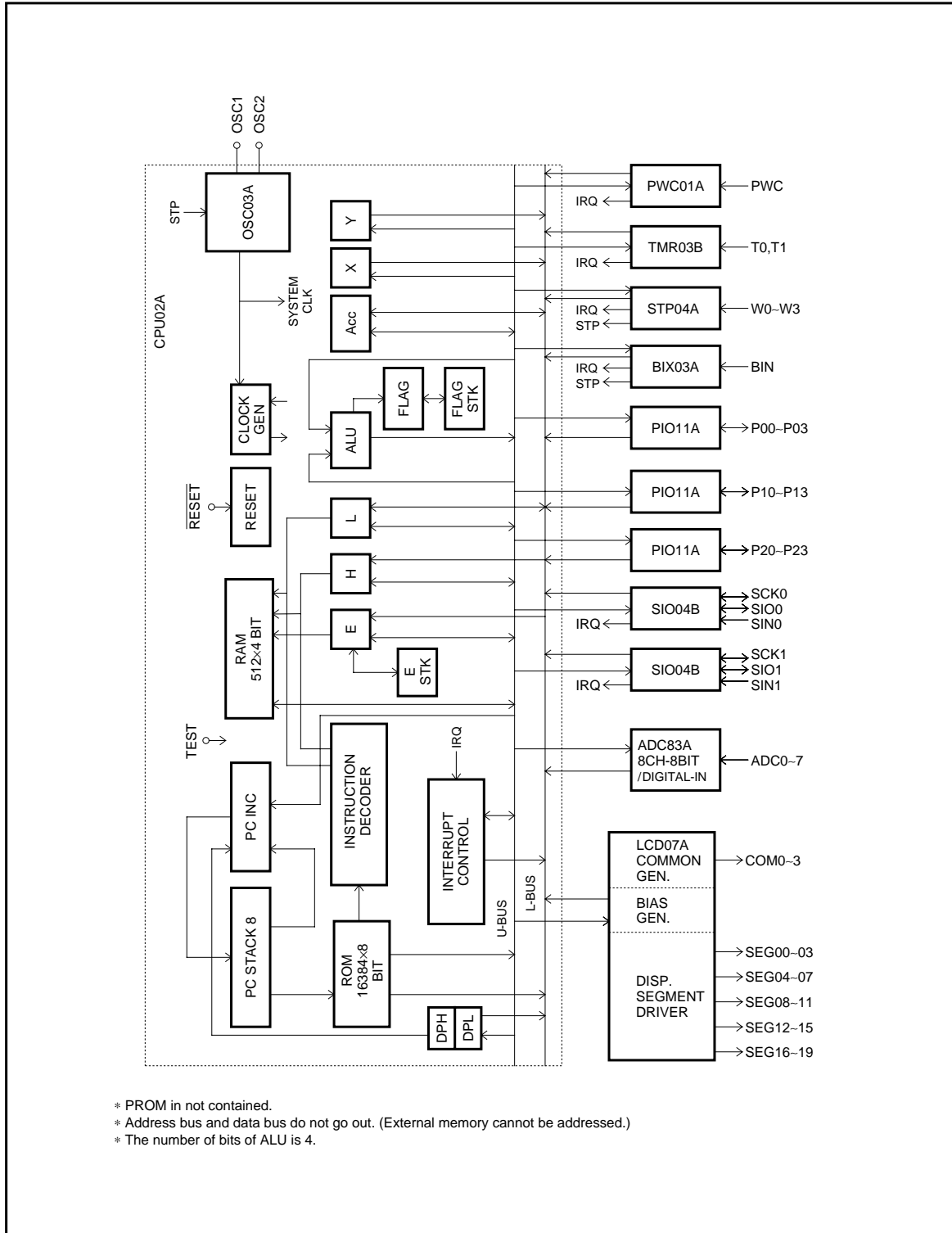

* PROM is not contained.
 * Address bus and data bus do not go out. (External memory cannot be addressed.)
 * The number of bits of ALU is 4.

Optical ICs

●Pin assignment

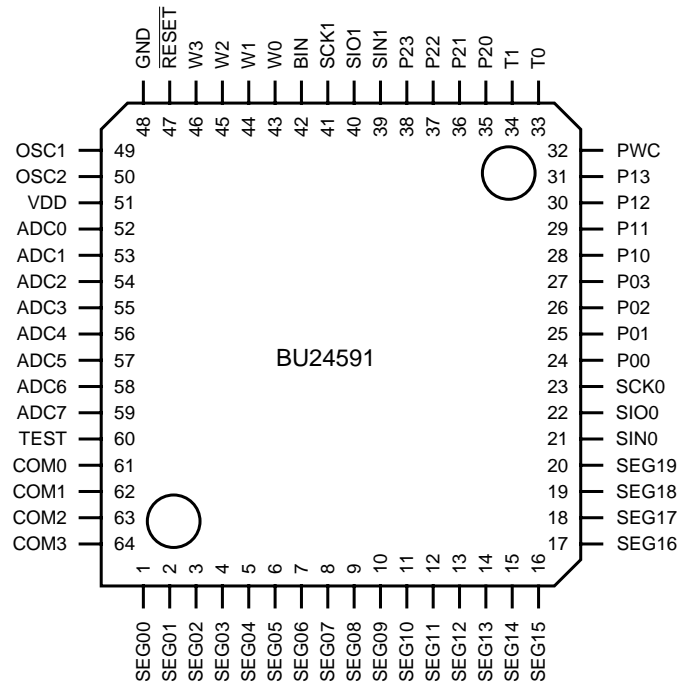

●Pin descriptions

Pin No.	Pin name	I / O	Function	Type
24 to 27 28 to 31 35 to 38	P00 to P03 P10 to P13 P20 to P23 (PI011A block)	I / O	<ul style="list-style-type: none"> • 4-bit input or output. • Input/Output is specified in a bit by program. (Output is Nch open drain type.) • Pull-up resistor can be turned ON/OFF in a bit by program. • Upon resetting, input is specified, and the pull-up resistance is turned OFF. *1 	D
43 to 46	W0 to W3 (STP04A block)	I	<ul style="list-style-type: none"> • General 4-bit input. • It can be used as stop cancellation input and interrupt request signal input by program. (It can be specified in a bit) • Pull-up resistor can be turned ON/OFF in a bit by program. • Upon resetting, the pull-up resistor is turned OFF. 	C
42	BIN (BIX03A block)	I	<ul style="list-style-type: none"> • General 1-bit input. • It can be used as stop cancellation input and interrupt request signal input by program. • Pull-up resistor can be turned ON/OFF by program. • Upon resetting, the pull-up resistor is turned OFF. 	C

*1 Immediately after resetting, terminal is in high impedance state. Therefore, termination may be required in some applications.

Optical ICs

Pin No.	Pin name	I / O	Function	Type
21, 39	SIN0, SIN1	I	• 8-bit serial data input.	A
22, 40	SIO0, SIO1	I / O	• 8-bit serial data I/O. • I/O is switched by program.	E
23, 41	SCK0, SCK1 (SIO04B block)	I / O	• Clock I/O for sending/receiving serial data. • Any of three type of internal clock and one external clock is switched by program.	E
52 to 59	ADC0 to ADC7 (ADC83A block)	I	• Analog data input. • Digital data input can be specified in a bit by program. • Upon resetting, analog input is specified.	G
1 to 4 5 to 8 9 to 12 13 to 16 17 to 20	SEG00 to 03 SEG04 to 07 SEG08 to 11 SEG12 to 15 SEG16 to 19	O	• LCD segment output or CMOS output can be switched in 4 ports by program. • Upon resetting, CMOS output is specified and polarity is "L".	F
61 to 64	COM0 to COM3 (LCD07A block)	O	• LCD common output. • Upon selecting 1/3 duty, COM3 outputs GND level.	F
32	PWC (PWC01A block)	I	• Pulse input.	A
33, 34	T0, T1 (TMR03B block)	I	• External count clock input. • It can be used as 1-bit input.	A
49	OSC1	I	• Oscillation circuit input. • External clock input.	H
50	OSC2 (OSC03A block)	O	• Oscillation circuit output.	H
60	TEST	I	• Test input. (This is a terminal for testing and it contains the pull-down resistor. Use it in the open state usually.)	B
47	$\overline{\text{RESET}}$	I	• Reset input. (CPU is reset by setting this terminal to "L".)	A
51	V _{DD}	–	• Power supply	–
48	GND	–	• Ground	–

Optical ICs

●Input output circuit

TYPE A

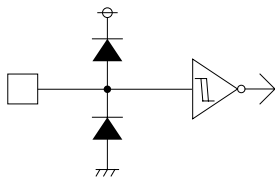

• Hysteresis input

TYPE B

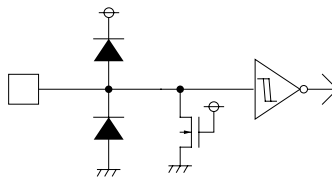

• Hysteresis input with pull-down resistance.

TYPE C

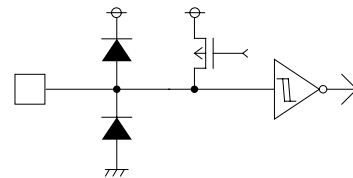

• Hysteresis input with pull-up resistance which can be turned ON/OFF by program.

TYPE D

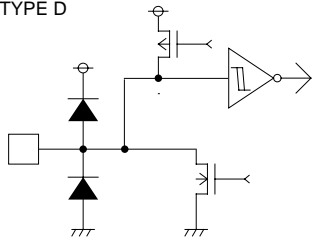

• Hysteresis input with pull-up resistance or Nch open drain output, which can be controlled by program.

TYPE E

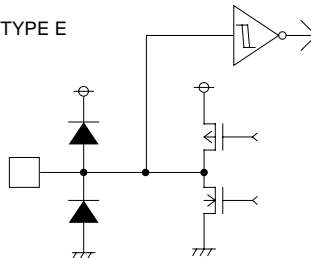

• Hysteresis input or CMOS output, which can be controlled by program.

TYPE F

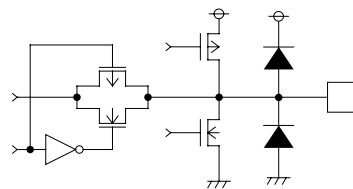

• LCD driver output. Only SEG can be switched into CMOS output.

TYPE G

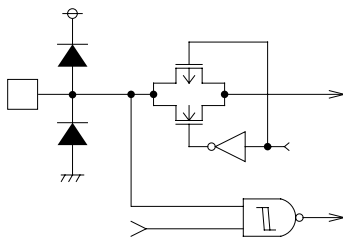

• Analog input or Hysteresis input, which can be controlled by program.

TYPE H

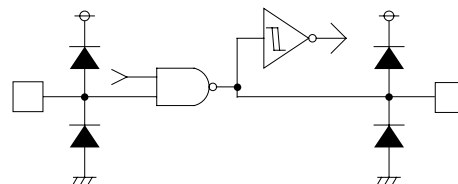

• Input and output of oscillation circuit with STOP control.

* All digital inputs are CMOS gate input.

Fig.1

Optical ICs

●Electrical characteristics (unless otherwise noted, Ta=25°C, VDD=3V)

Parameter	Symbol	Pin	Min.	Typ.	Max.	Unit	Conditions
STOP current	I _{DST}		–	–	1	μA	• STOP mode
Operation current	I _{DOP}		–	1.4	–	mA	• f _{osc} =4.4MHz
Clock frequency	f _{osc}	OSC1, OSC2	2	–	4.4	MHz	
Input "H" voltage 1	V _{IH1}	P00 to P03, P10 to P13, P20 to P23, T0, T1, ADC0 to ADC7 W0 to W3, BIN, SINO, SIN1, SIO0, SIO1, SCK0, SCK1, PWC, RESET, TEST	2.25	–	–	V	• Hysteresis input • P, SIO, SCK for input. • ADC for digital input.
Input "H" voltage 2	V _{IH2}	OSC1	2.4	–	–	V	• External clock
Input "L" voltage 1	V _{IL1}	P00 to P03, P10 to P13, P20 to P23, T0, T1, ADC0 to ADC7 W0 to W3, BIN, SINO, SIN1, SIO0, SIO1, SCK0, SCK1, PWC, RESET, TEST	–	–	0.5	V	• Hysteresis input • P, SIO, SCK for input. • ADC for digital input.
Input "L" voltage 2	V _{IL2}	OSC1	–	–	0.5	V	• External clock
Input "H" current 1	I _{IH1}	P00 to P03, P10 to P13, P20 to P23, W0 to W3, BIN, SINO, SIN1, SIO0, SIO1, SCK0, SCK1, ADC0 to ADC7, PWC, T0, T1, RESET, OSC1	–	–	1	μA	• Without pull-down resistance • P, SIO, SCK for input. • V _{IN} =V _{DD}
Input "H" current 2	I _{IH2}	TEST	120	230	410	μA	• Pull-down resistance included • V _{IN} =V _{DD}
Input "L" current 1	I _{IL1}	P00 to P03, P10 to P13, P20 to P23, W0 to W3, BIN, SINO, SIN1, SIO0, SIO1, SCK0, SCK1, ADC0 to ADC7, PWC, T0, T1, RESET, TEST, OSC1	–	–	–1	μA	• W, BIN turned off pull-up resistance • P for input turned off pull-up resistance • SIO, SCK for input • V _{IN} =GND
Input "L" current 2	I _{IL2}	P00 to P03, P10 to P13, P20 to P23, W0 to W3, BIN	–35	–82	–150	μA	• Turned on pull-up resistance • V _{IN} =GND
Output "H" voltage 1	V _{OH1}	SIO0, SIO1, SCK0, SCK1 SEG00 to SEG19, COM0 to COM3	2.4	–	–	V	• SIO, SCK for output • SEG, COM for LCD driver output • I _{OH} =–500μA
Output "H" voltage 2	V _{OH2}	OSC2	2.5	–	–	V	• I _{OH} =–1.0mA
Output "L" voltage 1	V _{OL1}	P00 to P03, P10 to P13, P20 to P23, SIO0, SIO1, SCK0, SCK1 SEG00 to SEG19, COM0 to COM3	–	–	0.4	V	• P, SIO, SCK for output • SEG, COM for LCD driver output • I _{OL} =1.6mA
Output "L" voltage 2	V _{OL2}	OSC2	–	–	0.4	V	• I _{OL} =1.0mA
Output leak current	I _L	P00 to P03, P10 to P13, P20 to P23	–	–	1	μA	• P for Hi-Z output
A/D conversion resolution	RES	ADC0 to ADC7	–	8	–	bits	
A/D conversion setting time	t _s	ADC0 to ADC7	–	25	–	MC	MC : machine cycle *1
A/D conversion linearity error	E _L	ADC0 to ADC7	–	–	±3	LSB	*2
LCD 2/3 level output voltage	V ₁	COM0 to COM3 SEG00 to SEG19	–	2	–	V	
LCD 1/3 level output voltage	V ₂	COM0 to COM3 SEG00 to SEG19	–	1	–	V	

*1 1 machine cycle is 1/6 of 1 clock cycle.

*2 Value of linearity error when bypass-capacitor is set on ADC terminal.

Optical ICs

●Circuit operation

- (1) Single power supply operation ($V_{DD}=2.3V$ to $3.6V$)
- (2) Memory size

Program memory ROM	16384×8 bits
General Purpose RAM	512×4 bits
RAM for LCD	20×4 bits
- (3) Instruction execution time. (one-cycle instruction)
1.5μsec (at 4MHz)
- (4) Subroutine nesting: 8 levels
- (5) Interrupts: 6

External:	3
Internal:	3 (Timer/counter, serial I/O)
- (6) ROM data table function (Data table area 16KBytes)
- (7) Power saving mode.
- (8) 20-Segment LCD built-in driver available for many kinds of displays.

Bias:	1/3
Duty:	1/3, 1/4 (programmable)

 Built-in bias resistance (approximately $50k\Omega \times 3$ stages)
- (9) LCD segment output can be switched into CMOS output by program.
20 Segments can be switched in 4 ports.
Upon resetting, CMOS output is specified and polarity is "L".
- (10) Remote-control receiver circuit is included. (Pulse width measuring instrument)
- (11) 8-channel 8-bit A/D converter is included.
- (12) Each of A/D inputs can be used as digital input by program.
- (13) Built-in 8-bit timer counter (als used for event counter).
- (14) Built-in two systems of serial I/O that can interface with any external LSI. (LSB first)
- (15) 12 I/O ports that can pull up by program.
- (16) 5 input port that can pull up by program.

●External dimensions (Units : mm)

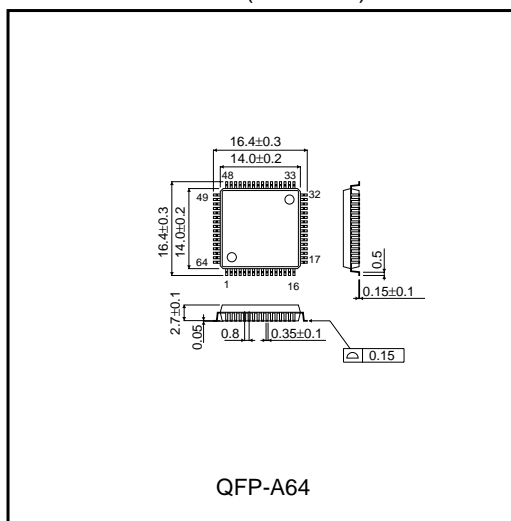

Notes

- No technical content pages of this document may be reproduced in any form or transmitted by any means without prior permission of ROHM CO.,LTD.
- The contents described herein are subject to change without notice. The specifications for the product described in this document are for reference only. Upon actual use, therefore, please request that specifications to be separately delivered.
- Application circuit diagrams and circuit constants contained herein are shown as examples of standard use and operation. Please pay careful attention to the peripheral conditions when designing circuits and deciding upon circuit constants in the set.
- Any data, including, but not limited to application circuit diagrams information, described herein are intended only as illustrations of such devices and not as the specifications for such devices. ROHM CO.,LTD. disclaims any warranty that any use of such devices shall be free from infringement of any third party's intellectual property rights or other proprietary rights, and further, assumes no liability of whatsoever nature in the event of any such infringement, or arising from or connected with or related to the use of such devices.
- Upon the sale of any such devices, other than for buyer's right to use such devices itself, resell or otherwise dispose of the same, no express or implied right or license to practice or commercially exploit any intellectual property rights or other proprietary rights owned or controlled by
- ROHM CO., LTD. is granted to any such buyer.
- Products listed in this document use silicon as a basic material.
Products listed in this document are no antiradiation design.

The products listed in this document are designed to be used with ordinary electronic equipment or devices (such as audio visual equipment, office-automation equipment, communications devices, electrical appliances and electronic toys).

Should you intend to use these products with equipment or devices which require an extremely high level of reliability and the malfunction of which would directly endanger human life (such as medical instruments, transportation equipment, aerospace machinery, nuclear-reactor controllers, fuel controllers and other safety devices), please be sure to consult with our sales representative in advance.

About Export Control Order in Japan

Products described herein are the objects of controlled goods in Annex 1 (Item 16) of Export Trade Control Order in Japan.

In case of export from Japan, please confirm if it applies to "objective" criteria or an "informed" (by MITI clause) on the basis of "catch all controls for Non-Proliferation of Weapons of Mass Destruction.