

3-channel 8-bit D / A converter

BU3618K

The BU3618K is an RGB 3-channel, 8-bit D / A converter CMOS IC featuring high speed and low power consumption. An internal reference voltage supply eliminates the need to provide an external reference voltage supply.

●Applications

Video-CDs, CD-Vs, CD karaoke sets

●Features

- 1) 8-bit resolution.
- 2) Current output model.
- 3) Low power consumption.
- 4) High-speed operation enabled.
- 5) Internal reference voltage supply.
- 6) TTL input.

●Block diagram

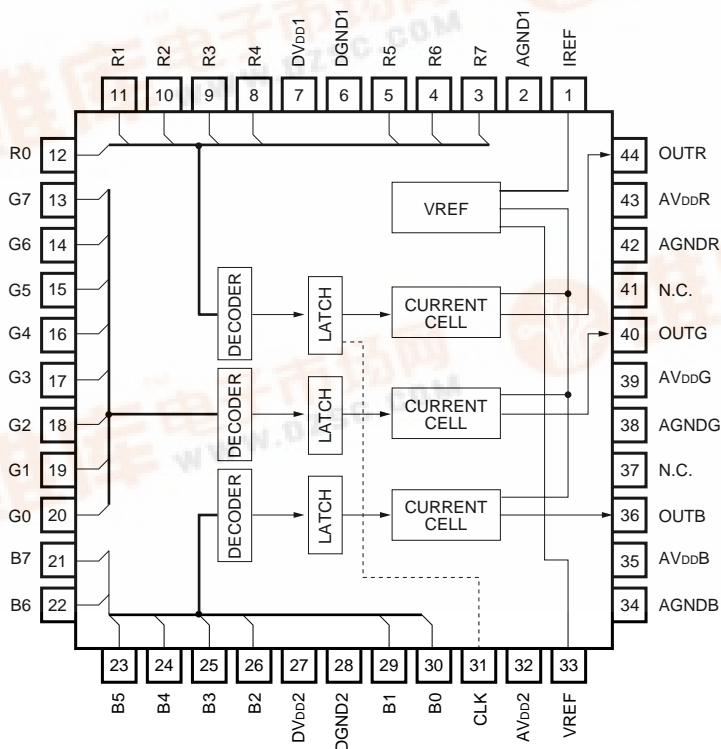

● Pin descriptions

Pin No.	I / O	Pin name	Function
1	—	IREF	For connection of output current adjustment resistor, VREF output
2	—	AGND1	Analog ground 1
3	I	R7	RED data input (bit 7, MSB)
4	I	R6	RED data input (bit 6)
5	I	R5	RED data input (bit 5)
6	—	DGND1	Digital ground 1
7	—	DV _{DD1}	Digital power supply 1
8	I	R4	RED data input (bit 4)
9	I	R3	RED data input (bit 3)
10	I	R2	RED data input (bit 2)
11	I	R1	RED data input (bit 1)
12	I	R0	RED data input (bit 0, LSB)
13	I	G7	GREEN data input (bit 7, MSB)
14	I	G6	GREEN data input (bit 6)
15	I	G5	GREEN data input (bit 5)
16	I	G4	GREEN data input (bit 4)
17	I	G3	GREEN data input (bit 3)
18	I	G2	GREEN data input (bit 2)
19	I	G1	GREEN data input (bit 1)
20	I	G0	GREEN data input (bit 0, LSB)
21	I	B7	BLUE data input (bit 7, MSB)
22	I	B6	BLUE data input (bit 6)

Pin No.	I / O	Pin name	Function
23	I	B5	BLUE data input (bit 5)
24	I	B4	BLUE data input (bit 4)
25	I	B3	BLUE data input (bit 3)
26	I	B2	BLUE data input (bit 2)
27	—	DV _{DD2}	Digital power supply 2
28	—	DGND2	Digital ground 2
29	I	B1	BLUE data input (bit 1)
30	I	B0	BLUE data input (bit 0, LSB)
31	I	CLK	System clock
32	—	AV _{DD2}	Analog power supply 2
33	O	VREF	External capacitor connection pin (C = 0.1μF)
34	—	AGNDB	Analog ground B
35	—	AV _{DDB}	Analog power supply B
36	O	OUTB	BLUE output
37	—	N.C.	—
38	—	AGNDG	Analog ground G
39	—	AV _{DDG}	Analog power supply G
40	O	OUTG	GREEN output
41	—	N.C.	—
42	—	AGNDR	Analog ground R
43	—	AV _{DDR}	Analog power supply R
44	O	OUTR	RED output

● Absolute maximum ratings (Ta = 25°C)

Parameter	Symbol	Limits	Unit
Power supply voltage	DV _{DD}	- 0.5 ~ + 7.0	V
Analog power supply voltage	AV _{DD}	DV _{DD} - 0.3 ~ DV _{DD} + 0.3	V
Input voltage	V _{IN}	- 0.5 ~ DV _{DD} + 0.5	V
Output voltage	V _{OUT}	- 0.5 ~ DV _{DD} + 0.5	V
Storage temperature	T _{stg}	- 55 ~ + 125	°C
Power dissipation	P _D	500*1	mW

*1 Reduced by 5mW for each increase in Ta of 1°C over 25°C.

● Recommended operating conditions

Parameter	Symbol	Min.	Typ.	Max.	Unit
Digital power supply voltage	DV _{DD}	4.5	5.0	5.5	V
Analog power supply voltage	AV _{DD}	4.5	5.0	5.5	V
Transmission clock width	TCK	25	—	—	ns
Transmission clock low level width	TCKL	10	—	—	ns
Setup time	TS	8	—	—	ns
Hold time	TH	8	—	—	ns
Input low level voltage	V _{IL}	0.0	—	0.8	V
Input high level voltage	V _{IH}	2.2	—	V _{CC}	V
Operating temperature	TOPR	- 20	—	75	°C

● Electrical characteristics (unless otherwise noted, Ta = 25°C, DV_{DD} = AV_{DD} = 5.0V)

Parameter	Symbol	Min.	Typ.	Max.	Unit	Conditions
Current consumption	I _{CC}	—	33	70	mA	FCK = 40MHz, PREF = 2.2kΩ RL = 150Ω
Differential linearity error	E _D	- 0.5	—	0.5	LSB	PREF = 2.2kΩ, RL = 150Ω
Integral linearity error	E _L	- 1.0	—	1.0	LSB	
RGB output full-scale voltage	FS	1.24	1.38	1.52	V	
RGB output voltage ratio	F _{SCR}	0	0.5	5.0	%	
Output delay time	T _D	—	20	—	ns	—
Settling time	T _{SET}	—	10	—	ns	CL = 15pF

●Application example

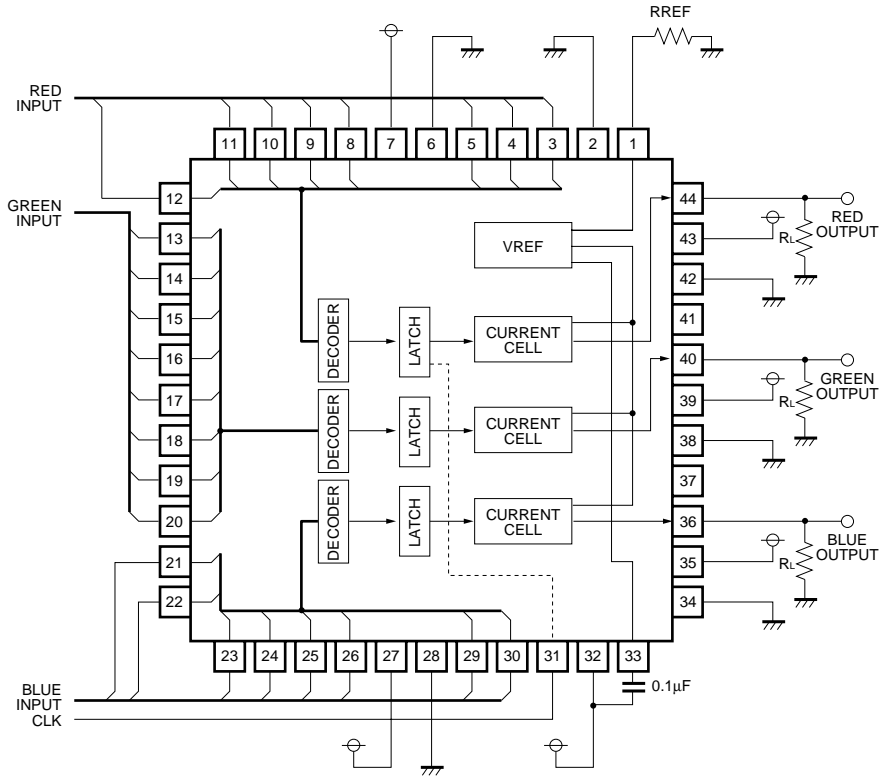

Fig. 1

●Input / output circuits

Pin No.	Pin name	Equivalent circuit
3 ~ 5 8 ~ 26 29 ~ 31	R0 ~ R7, G0 ~ G7 B0 ~ B7, CLK	
36, 40, 44	OUTR, OUTG OUTB	
1, 33	IREF, VREF	

●Circuit operation

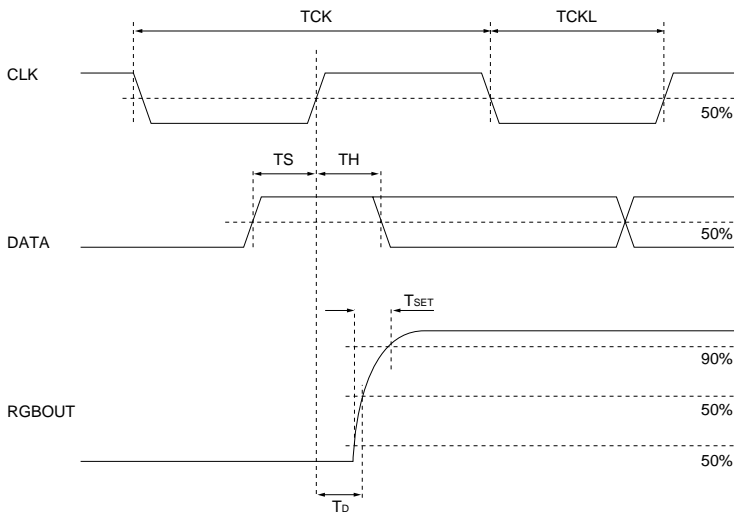

Fig. 2 Input / output interface timing

●External dimensions (Units: mm)

