

# Triple 2-channel analog multiplexer / demultiplexer

## BU4053BC / BU4053BCF / BU4053BCFV

The BU4053BC, BU4053BCF, and BU4053BCFV are multiplexers / demultiplexers capable of selecting and combining analog signals and digital signals in a 2 ch × 3 configuration. Inhibit signals and control signals are used to turn on the switch corresponding to each of the channels. In addition, even if the logical amplitude ( $V_{DD}$ - $V_{SS}$ ) of the control signal is low, signals with a large amplitude ( $V_{DD}$ - $V_{EE}$ ) can be switched.

Also, as each switch has a low ON resistance, it can be connected to a low impedance circuit.

### ●Block diagram

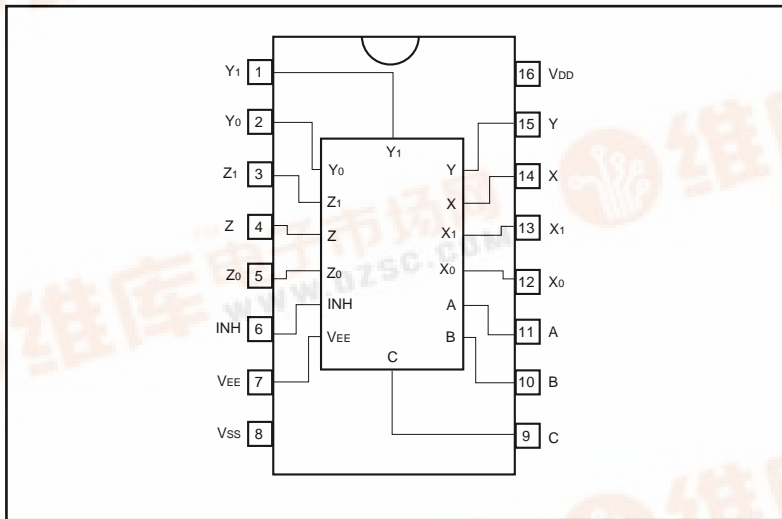

### ●Logic circuit diagram

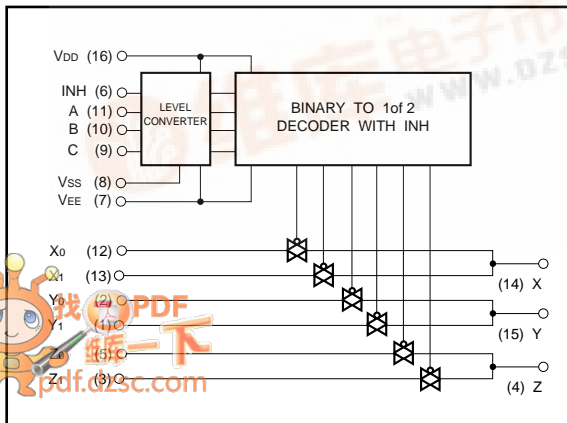

### ●Truth table

INH	A	B	C	ON SWITCH
L	L	L	L	X <sub>0</sub> Y <sub>0</sub> Z <sub>0</sub>
L	H	L	L	X <sub>1</sub> Y <sub>0</sub> Z <sub>0</sub>
L	L	H	L	X <sub>0</sub> Y <sub>1</sub> Z <sub>0</sub>
L	H	H	L	X <sub>1</sub> Y <sub>1</sub> Z <sub>0</sub>
L	L	L	H	X <sub>0</sub> Y <sub>0</sub> Z <sub>1</sub>
L	H	L	H	X <sub>1</sub> Y <sub>0</sub> Z <sub>1</sub>
L	L	H	H	X <sub>0</sub> Y <sub>1</sub> Z <sub>1</sub>
L	H	H	H	X <sub>1</sub> Y <sub>1</sub> Z <sub>1</sub>
H	X	X	X	NONE

X: Irrelevant

## Standard ICs

## BU4053BC / BU4053BCF / BU4053BCFV

### ●Absolute maximum ratings (Ta = 25°C)

Parameter	Symbol	Limits	Unit
Power supply voltage1	V <sub>DD</sub>	- 0.5 ~ + 20	V
Power supply voltage2	V <sub>DD</sub> - V <sub>EE</sub>	- 0.5 ~ + 20	V
Power dissipation	P <sub>d</sub>	1000 (DIP), 500 (SOP), 400 (SSOP)	mW
Operating temperature	T <sub>opr</sub>	- 40 ~ + 85	°C
Storage temperature	T <sub>stg</sub>	- 55 ~ + 150	°C
Input voltage	V <sub>IN</sub>	- 0.5 ~ V <sub>DD</sub> + 0.5	V

### ●Electrical characteristics

DC characteristics (unless otherwise noted, Ta = 25°C, V<sub>EE</sub> = V<sub>SS</sub> = 0V)

Parameter	Symbol	Min.	Typ.	Max.	Unit	V <sub>DD</sub> (V)	Conditions	Measurement circuit
Input high-level voltage	V <sub>IH</sub>	3.5	—	—	V	5	—	Fig.1
		7.0	—	—		10		
		11.0	—	—		15		
Input low-level voltage	V <sub>IL</sub>	—	—	1.5	V	5	—	Fig.1
		—	—	3.0		10		
		—	—	4.0		15		
Input high-level current	I <sub>IH</sub>	—	—	0.3	μA	15	V <sub>IH</sub> = 15V	Fig.1
Input low-level current	I <sub>IL</sub>	—	—	- 0.3	μA	15	V <sub>IL</sub> = 0V	Fig.1
R <sub>ON</sub> resistance	R <sub>ON</sub>	—	—	950	Ω	5	V <sub>IN</sub> = V <sub>DD</sub> / 2	Fig.2
		—	—	250		10		
		—	—	160		15		
R <sub>ON</sub> resistance deflexion	ΔR <sub>ON</sub>	—	10	—	Ω	5	—	Fig.2
		—	6	—		10		
		—	4	—		15		
OFF-channel leakage current	I <sub>OFF</sub>	—	—	0.3	μA	15	—	Fig.3
		—	—	- 0.3		15		
Static current dissipation	I <sub>DD</sub>	—	—	5	μA	5	V <sub>I</sub> = V <sub>DD</sub> or GND	—
		—	—	10		10		
		—	—	15		15		

# Standard ICs

# BU4053BC / BU4053BCF / BU4053BCFV

Switching characteristics (unless otherwise noted,  $T_a = 25^\circ\text{C}$ ,  $V_{EE} = V_{SS} = 0\text{V}$ ,  $R_L = 1\text{k}\Omega$ ,  $C_L = 50\text{pF}$ )

Parameter	Symbol	Min.	Typ.	Max.	Unit	V <sub>DD</sub> (V)	Conditions	Measurement circuit
						5		
Propagation delay time Switch IN→OUT	t <sub>PLH</sub> , t <sub>PHL</sub>	—	15	45	ns	5	—	Fig.4
		—	8	20		10		
		—	6	15		15		
Propagation delay time CONT→OUT	t <sub>PHZ</sub> , t <sub>PLZ</sub> t <sub>PZH</sub> , t <sub>PZL</sub>	—	170	550	ns	5	—	Fig.5, 6
		—	90	240		10		
		—	70	160		15		
Propagation delay time INH→OUT	t <sub>PHZ</sub> , t <sub>PLZ</sub> t <sub>PZH</sub> , t <sub>PZL</sub>	—	150	380	ns	5	—	Fig.5, 6
		—	70	200		10		
		—	50	160		15		
Max. propagation frequency	f <sub>max</sub>	—	20	—	MHz	5	V <sub>EE</sub> = -5V*1	Fig.7
Feedthrough attenuation	FT	—	0.5	—	MHz	5	V <sub>EE</sub> = -5V*2	Fig.7
Sine wave distortion	D	—	0.02	—	%	5	V <sub>EE</sub> = -5V*3	Fig.7
Input capacitance (control)	C <sub>C</sub>	—	5	—	pF	—	—	—
Input capacitance (switch)	C <sub>S</sub>	—	10	—	pF	—	—	—

\*1 V<sub>IN</sub> = 5V<sub>p-p</sub> sine wave, frequency that enables  $20 \log_{10} \frac{V_{OUT}}{V_{IN}} = -3\text{dB}$ .

\*2 V<sub>IN</sub> = 5V<sub>p-p</sub> sine wave, frequency that enables  $20 \log_{10} \frac{V_{OUT}}{V_{IN}} = -50\text{dB}$  at channel off.

\*3 V<sub>IN</sub> = 5V<sub>p-p</sub> sine wave.

## ● Measurement circuits

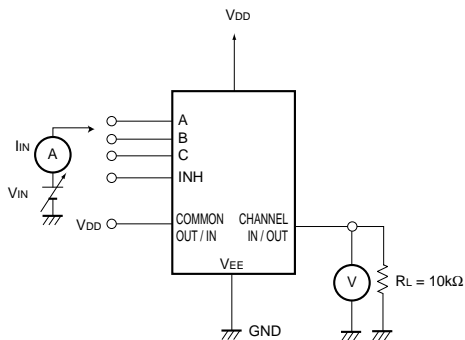

Fig. 1 Input voltage, current

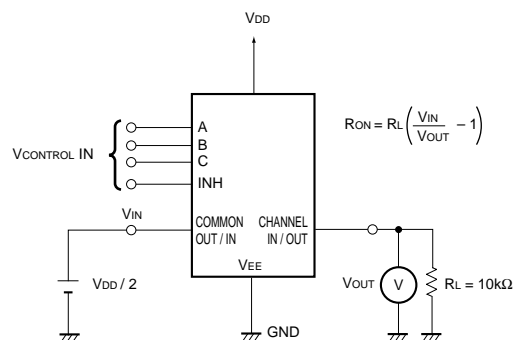

Fig. 2 ON resistance

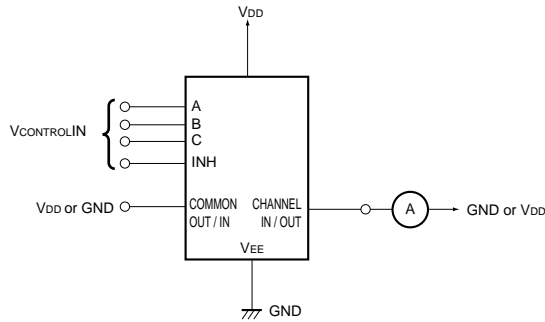

Fig. 3 Channel-OFF leakage current

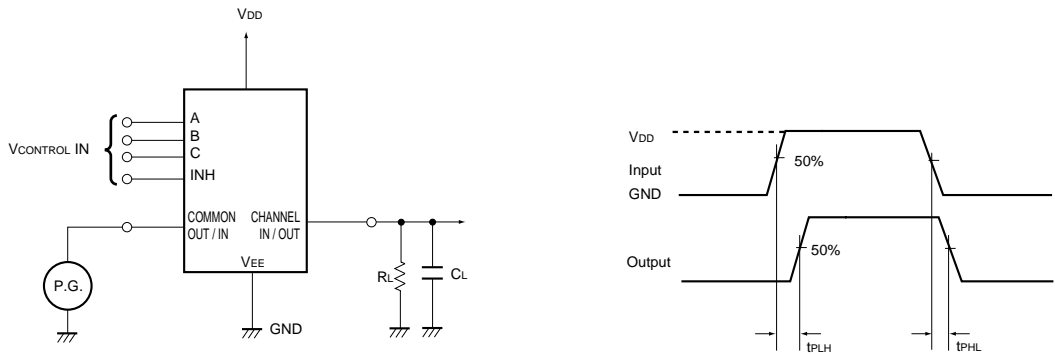

Fig. 4 Propagation delay time (Switch IN to OUT)

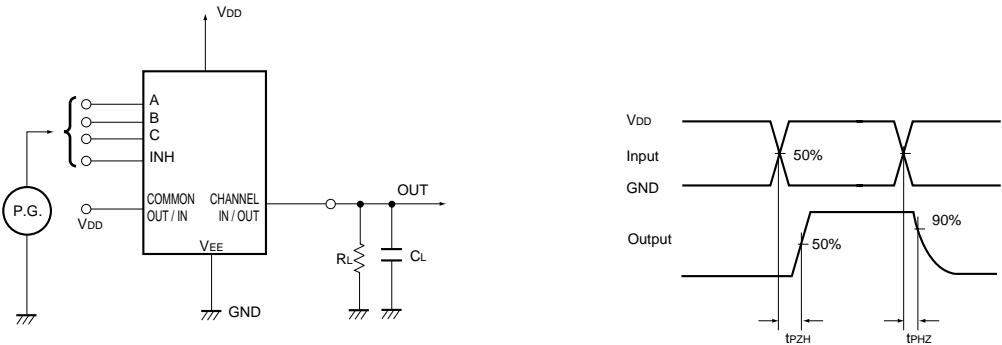

Fig. 5 Propagation delay time (CONT, INH to OUT)

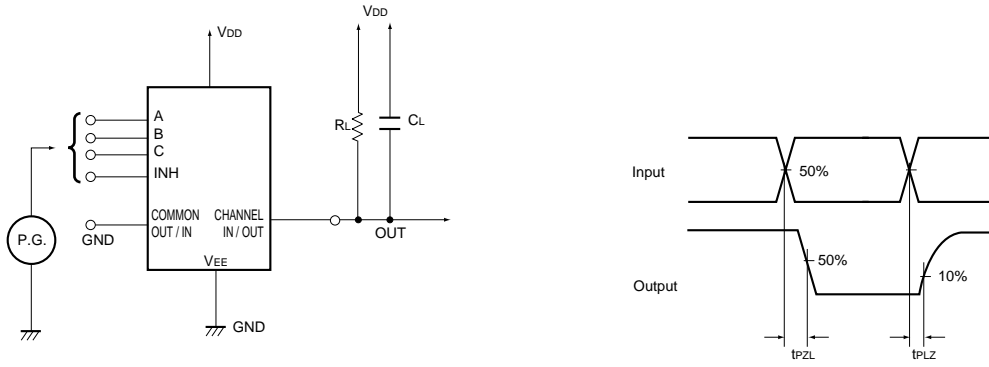

Fig. 6 Propagation delay time (CONT, INH to OUT)

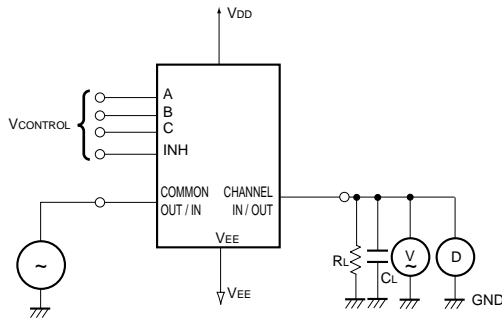

Fig. 7 Maximum propagation frequency, feedthrough, sine wave distortion

●Electrical characteristic curve

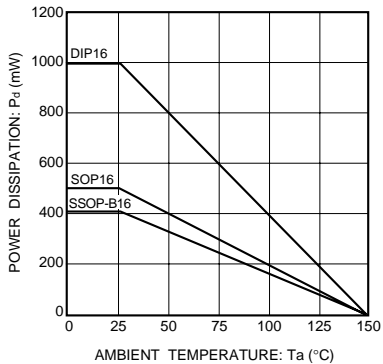

Fig. 8 Power dissipation vs. Ta

● External dimensions (Units: mm)

