

Single 2-input AND gate

BU4S81

The BU4S81 is an ultra-compact IC with one dual-input positive logic AND gate BU4081B circuit built into an SMP.

●Features

- 1) Low current dissipation.
- 2) Super-mini mold package designed for surface mounting.
- 3) Wide range of operating power supply voltages.
- 4) Direct drive of 2 L-TTL inputs and 1 LS-TTL input.

●Block diagram

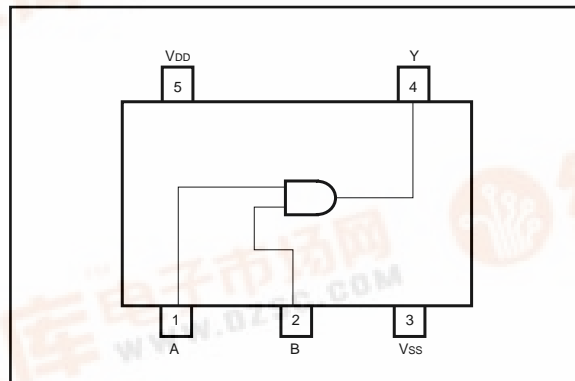

●Absolute maximum ratings (Ta = 25°C)

Parameter	Symbol	Limits	Unit
Power supply voltage	V _{DD}	V _{SS} - 0.3 ~ V _{SS} + 18	V
Power dissipation	P _d	170	mW
Input current	I _{IN}	± 10	mA
Operating temperature	T _{opr}	- 40 ~ + 85	°C
Storage temperature	T _{stg}	- 55 ~ + 150	°C
Input voltage	V _{IN}	V _{SS} - 0.3 ~ V _{DD} + 0.3	V

*1 These values indicate the limits at which voltage can be applied to the terminal without causing destruction, but operation is not guaranteed at these values.

*2 Power dissipation is reduced by 1.7mW for each increase in Ta of 1°C over 25°C.

●Recommended operating conditions (Ta = 25°C, V_{SS} = 0V)

Parameter	Symbol	Min.	Typ.	Max.	Unit
Power supply voltage	V _{DD}	3	—	16	V
Input voltage	V _{IN}	0	—	V _{DD}	V

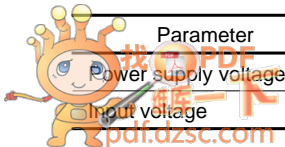

●Electrical characteristics

DC characteristics (unless otherwise noted, Ta = 25°C, Vss = 0V)

Parameter	Symbol	Min.	Typ.	Max.	Unit	VDD (V)	Conditions	Measurement circuit
Input high level voltage	VIH	3.5	2.75	—	V	5	IOUT < 1μA	Fig.1
		7.0	5.5	—	V	10		
		11.0	8.25	—	V	15		
Input low level voltage	VIL	—	2.25	1.5	V	5	IOUT < 1μA	
		—	4.5	3.0	V	10		
		—	6.75	4.0	V	15		
Input high level current	IiH	—	—	0.3	μA	18	VIH = 18V	
Input low level current	IiL	—	—	-0.3	μA	18	VIL = 0V	
Output high level voltage	VOH	4.95	5.0	—	V	5	IOUT < 1μA VIN = VSS or VDD	
		9.95	10.0	—	V	10		
		14.95	15.0	—	V	15		
Output low level voltage	VOL	—	—	0.05	V	5	IOUT < 1μA VIN = VSS	
		—	—	0.05	V	10		
		—	—	0.05	V	15		
Output high level current	IoH	-0.51	-1.0	—	mA	5	VOH = 4.6V	
		-2.1	-4.0	—	mA	5	VOH = 2.5V	
		-1.3	-2.2	—	mA	10	VOH = 9.5V	
		-3.4	-9.0	—	mA	15	VOH = 13.5V	
Output low level current	IoL	0.51	1.2	—	mA	5	VOL = 0.4V	
		1.3	3.2	—	mA	10	VOL = 0.5V	
		3.4	12.0	—	mA	15	VOL = 1.5V	
Static current dissipation	IDD	—	0.001	0.25	μA	5	VIN = VSS or VDD	
		—	0.001	0.5	μA	10		
		—	0.002	1.0	μA	15		

Switching characteristics (unless otherwise noted, $T_a = 25^\circ\text{C}$, $V_{SS} = 0\text{V}$, $C_L = 50\text{pF}$)

Parameter	Symbol	Min.	Typ.	Max.	Unit	V_{DD} (V)	Conditions	Measurement circuit
						5		
Output rise time	t_{LH}	—	70	200	ns	5	—	Fig.2
		—	35	100	ns	10		
		—	30	80	ns	15		
Output fall time	t_{HL}	—	70	200	ns	5	—	
		—	35	100	ns	10		
		—	30	80	ns	15		
Propagation delay time	t_{PLH}	—	90	200	ns	5	—	
		—	45	100	ns	10		
		—	30	80	ns	15		
	t_{PHL}	—	90	200	ns	5	—	
		—	45	100	ns	10		
		—	30	80	ns	15		

● Measurement circuits

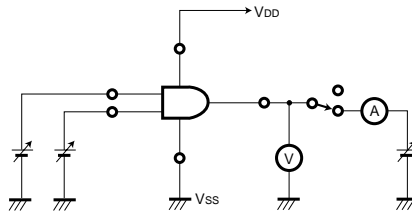

Fig.1 DC characteristics measurement circuit

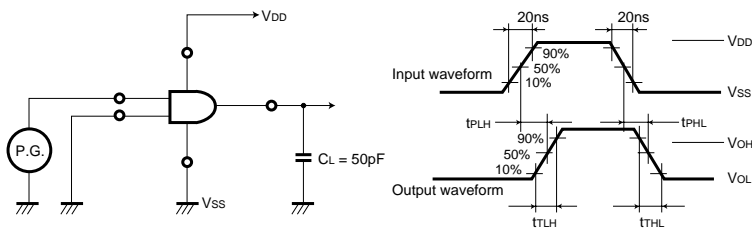

Fig.2 Switching characteristics measurement circuit

●External dimensions (Units: mm)

