

# Panel interface

## BU8310AK / BU8311KS / BU8313K

The BU8310AK, BU8311KS, and BU8313K are large-scale integrated circuits for telephones, which enable a serial input/output interface between the key input required for telephone panel boards and LED control functions. They reduce the number of wiring harnesses needed between the main board in the telephone and the panel board, and take some of the processing load off the main CPU.

### ●Applications

Telephones and cordless telephones

### ●Features

#### 1) Keypad matrix interface

- ① Key input is output as 16-bit serial data.
- ② Internal chattering prevention circuit built into the key input circuit.

#### 2) LED interface

- ① LED control commands input as 16-bit serial data.
- ② Bits with a pattern generator and pattern register can be assigned three independent flashing patterns in addition to being lighted or off.
- ③ Power consumption can be reduced using RST pin input.
- ④ LED on and off control can be initiated using ENA pin input or by commands setting all LEDs valid or invalid.



● Block diagram

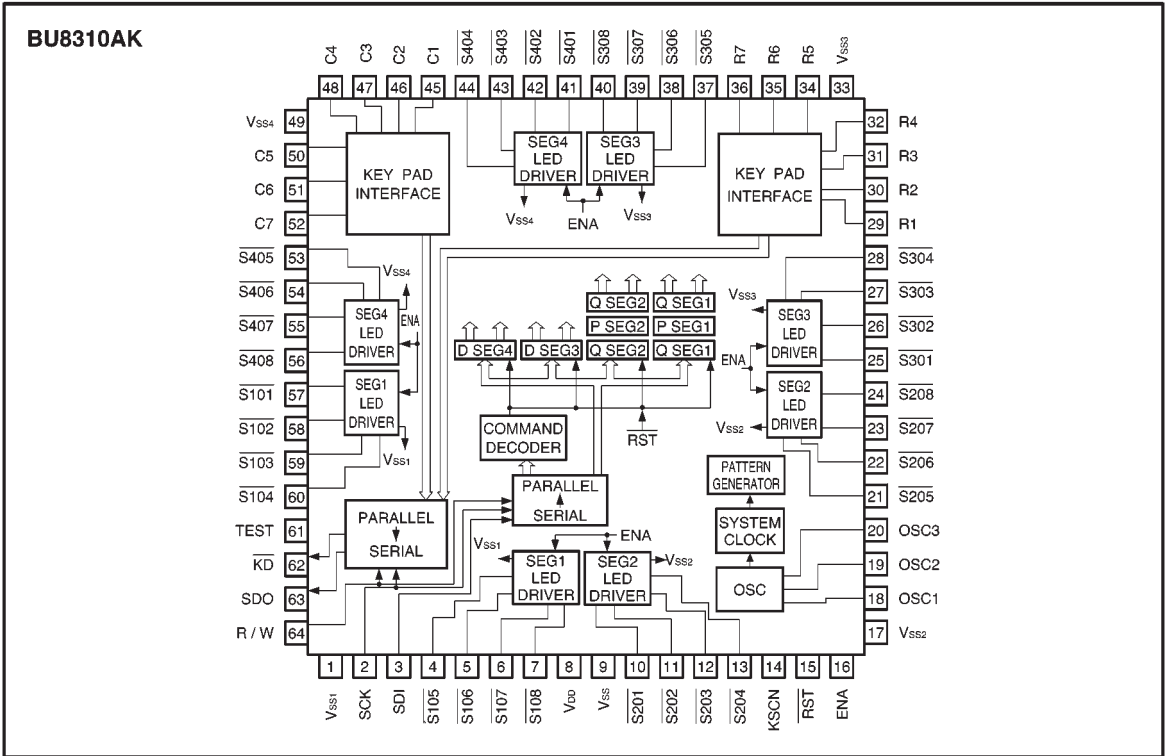

**BU8311KS**

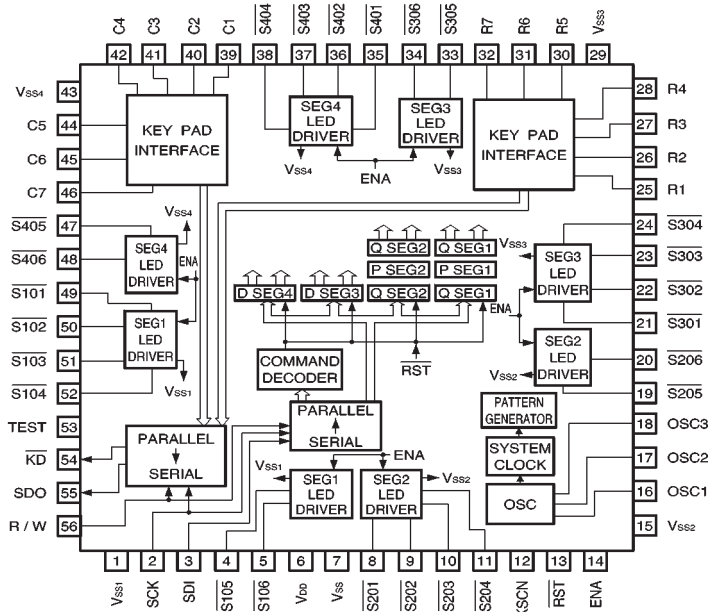

**BU8313K**

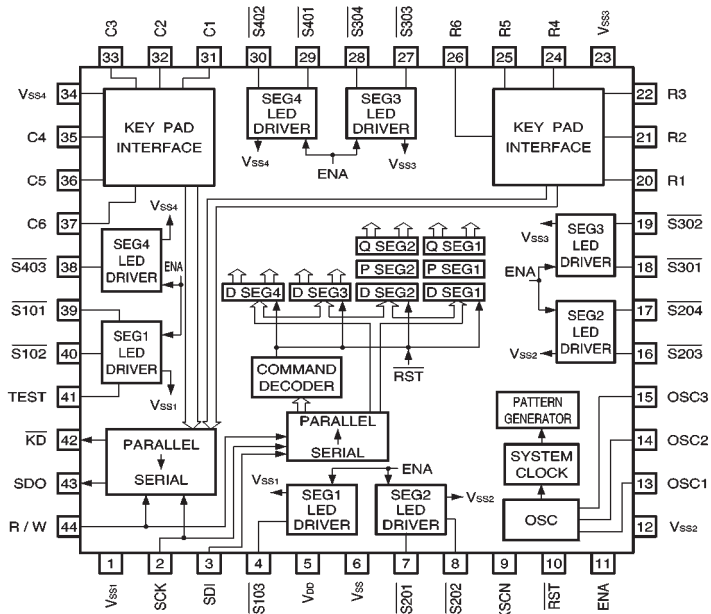

● Absolute maximum ratings (Ta = 25°C)

Parameter	Symbol	Limits	Unit	Conditions
Power supply voltage	V <sub>DD</sub>	7.0	V	—
Power dissipation	P <sub>d</sub>	500	mW	*1
Operating temperature	T <sub>opr</sub>	-25~+60	°C	—
Storage temperature	T <sub>stg</sub>	-55~+125	°C	—
Input voltage	V <sub>IN</sub>	V <sub>SS</sub> -0.3~V <sub>DD</sub> +0.3	V	*2
Output voltage 1	V <sub>OUT1</sub>	V <sub>SS</sub> -0.3~V <sub>DD</sub> +0.3	V	*3
Output voltage 2	V <sub>OUT2</sub>	V <sub>SS</sub> ~7.0	V	*4
Output current	I <sub>OUT</sub>	20	mA	*4

\*1 Reduced by 5mW for each increase in Ta of 1°C over 25°C.

\*2 SCK, SDI, ENA, RST, R/W, KSCN, and TEST pins

\*3 SDO and KD pins

\*4 LED drive output pins

● Recommended operating conditions

Parameter	Symbol	Limits	Unit	Conditions
Power supply voltage	V <sub>DD</sub>	1.8~5.5	V	—
Oscillation frequency	f <sub>osc</sub>	535	Hz	R <sub>i</sub> =2.2MΩ, R <sub>x</sub> =270kΩ C <sub>x</sub> =3.3nF
Key connection resistance	R <sub>KC</sub>	0~5	kΩ	—

● Pin descriptions

Pin No. BU8310AK	Pin No. BU8311KS	Pin No. BU8313K	Pin name	Function	I/O circuit
57~60 4~7 10~13 21~24 25~28 37~40 41~44 53~56	49~52 4~5 8~11 19~20 21~24 33~34 35~38 47~48	39~40 4 7~8 16~17 18~19 27~28 29~30 38	$\overline{S101} \sim \overline{S108}$ $\overline{S201} \sim \overline{S208}$ $\overline{S301} \sim \overline{S308}$ $\overline{S401} \sim \overline{S408}$	These are the output pins for LED drive. They are “L” when “1” is applied to the data register (D), and “Z” (high impedance) at all other times.	D
29~32 34~36 45~48 50~52	25~28 30~32 39~42 44~46	20~22 24~26 31~33 35~37	R1 ~ R4 R5 ~ R7 C1 ~ C4 C5 ~ C7	These are the keypad input pins. They are used to connect a single-contact keypad.	C
62	54	42	$\overline{KD}$	This is the output pin for the key press state. When a key is pressed, a “L” state is output. When no keys are pressed, these are “Z” (high impedance).	D
3	3	3	SDI	This is the serial data input pin. Data is output in the pertinent data format.	A
63	55	43	SDO	This is the serial data output pin. Data is output in the pertinent data format.	E
2	2	2	SCK	This is the shift clock input pin for serial data. Serial data is read from the SDO pin one bit at a time, at the rising edge, when R/W is “H”. SDI is written one bit at a time, at the rising edge, when R/W is “L”.	B

Pin No. BU8310AK	Pin No. BU8311KS	Pin No. BU8313K	Pin name	Function	I/O Circuit
64	56	44	R / W	This is the input pin which switches between the read and write modes. The read mode (serial output of key data) is accessed when this is "H". Key data is set to the output serial register at the falling edge. The write mode (serial input of data) is accessed when this key is "L". Serial data is taken up internally at the rising edge.	B
18~20	16~18	13~15	OSC1~OSC3	These are the I/O pins for the internal oscillator. The recommended values are as follows: $R_i=2.2M\Omega$ , $R_x=270k\Omega$ , $C_x=3.3nF$	F
14	12	9	KSCN	This is used for key scan control input. At "H", key scanning is carried out only when a key is pressed. At "L", key scanning is carried out at all times.	A
15	13	10	$\overline{RST}$	This is the reset signal input pin. Normal operation is carried out when this pin is "H". When this pin is "L", all data in the internal registers is reset, and the internal oscillator stops.	B
16	14	11	ENA	This is the input pin for LED ON/OFF control. At "H", output for LED drive is valid. At "L", all LED drive output is turned off.	A
61	53	41	TEST	This is the test input pin, and is normally used at "L".	A
8	6	5	V <sub>DD</sub>	This is the V <sub>DD</sub> pin	—
9	7	6	V <sub>SS</sub>	This is the V <sub>SS</sub> pin	—
1, 17, 33, 49	1, 15, 29, 43	1, 12, 23, 34	V <sub>SS1</sub> ~V <sub>SS4</sub>	These are the V <sub>SS</sub> pins for segments 1 to 4 of the LED drive output.	—

● Input/output circuits

Model A

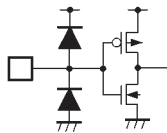

CMOS input

Model B

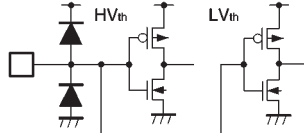

CMOS Schmitt trigger input

Model C

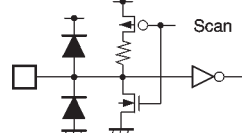

Keypad input

Model D

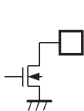

NMOS open drain output

Model E

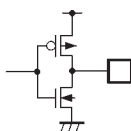

CMOS output

Model F

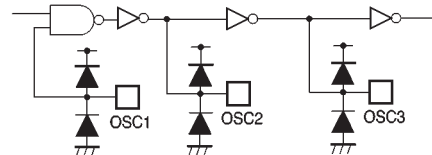

Oscillation circuit input/output

Fig. 1

●Electrical characteristics

DC characteristics (unless otherwise noted, Ta = 25°C, V<sub>DD</sub> = 3 ~ 5V)

Parameter	Symbol	Min.	Typ.	Max.	Unit	Conditions
Supply current 1	I <sub>DD1</sub>	—	0.01	2.0	μA	At rest ( $\overline{\text{RST}} = \text{L}$ )
Supply current 2	I <sub>DD2</sub>	—	7	20	μA	When operating V <sub>DD</sub> = 1.8V
Supply current 3	I <sub>DD3</sub>	—	70	200	μA	When operating V <sub>DD</sub> = 5.5V
Input high level voltage	V <sub>IH</sub>	0.8V <sub>DD</sub>	—	V <sub>DD</sub>	V	*1
Input low level voltage	V <sub>IL</sub>	0	—	0.2V <sub>DD</sub>	V	*1
Input high level current	I <sub>IH</sub>	—	—	1	μA	*1
Input low level current	I <sub>IL</sub>	—	—	1	μA	*1
Output high level voltage	V <sub>OH</sub>	0.9V <sub>DD</sub>	—	V <sub>DD</sub>	V	No load *2
Output low level voltage 1	V <sub>OL1</sub>	0	—	0.1V <sub>DD</sub>	V	No load *3
Output low level voltage 2	V <sub>OL2</sub>	0	—	0.5	V	*4

\*1 SCK, SDI, ENA,  $\overline{\text{RST}}$ , R/W, KSCN, and TEST pins

\*2 SDO pin

\*3 SDO and  $\overline{\text{KD}}$  pins

\*4 Values for LED drive output pins are at V<sub>DD</sub> = 5 V, I<sub>OL</sub> = 20 mA

AC characteristics (unless otherwise noted, Ta = 25°C, V<sub>DD</sub> = 3 ~ 5V)

Parameter	Symbol	Min.	Typ.	Max.	Unit	Conditions
SDI	Setup time	t <sub>SUI</sub>	100	—	—	ns
	Hold time	t <sub>HI</sub>	100	—	—	ns
Serial clock cycle	t <sub>CYC</sub>	500	—	—	ns	DUTY=50%
SDO output delay time	t <sub>DO</sub>	100	—	—	ns	
R / W	Setup time R	t <sub>SUR</sub>	100	—	—	ns
	Setup time W	t <sub>SUW</sub>	100	—	—	ns
	Setup time K	t <sub>SUK</sub>	500	—	—	ns
	Setup time S	t <sub>SUS</sub>	100	—	—	ns
	Pulse width R	t <sub>WR</sub>	500	—	—	ns
	Pulse width W	t <sub>WW</sub>	500	—	—	ns
$\overline{\text{RST}}$ pulse width	t <sub>WR</sub>	500	—	—	ns	
Key debounce time	t <sub>DB</sub>	—	30	—	ms	

Serial data output timing

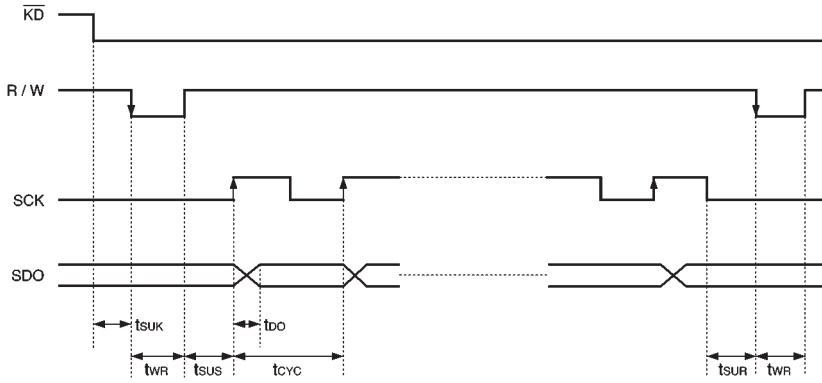

Serial data input timing

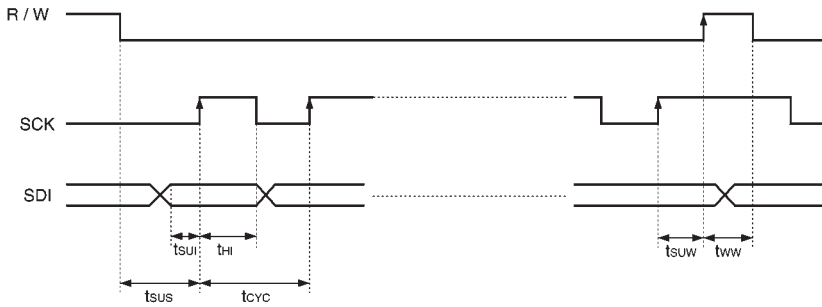

Fig. 2

## Communication ICs

## BU8310AK / BU8311KS / BU8313K

● Data formats (Serial data is input and output with the MSB coming first.)

### (1) Reading key data

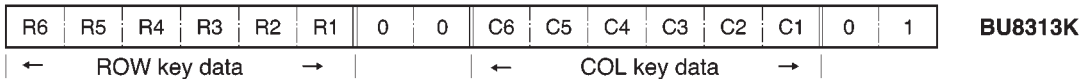
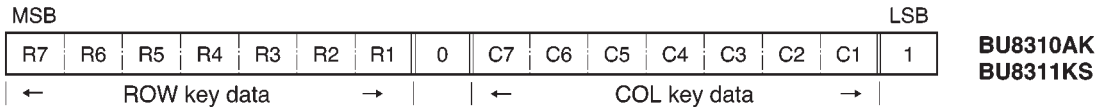

### (2) Data register write command

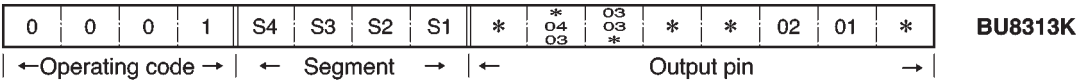
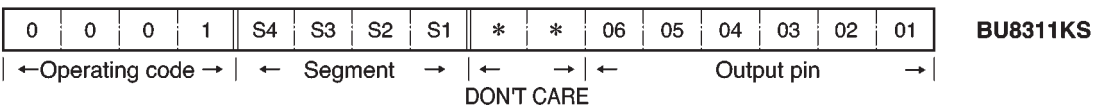
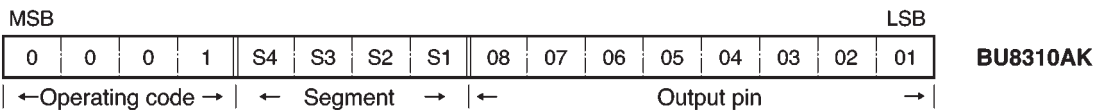

Note: The upper segment is Segment 1, the middle segments are 2 and 3, and the lower segment is 4.

### (3) Pattern register write command

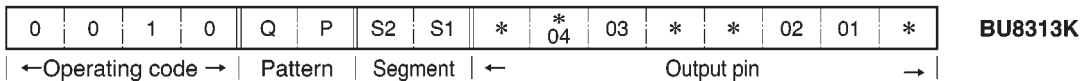
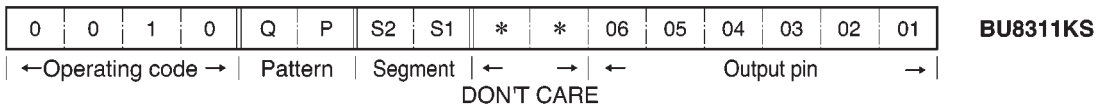
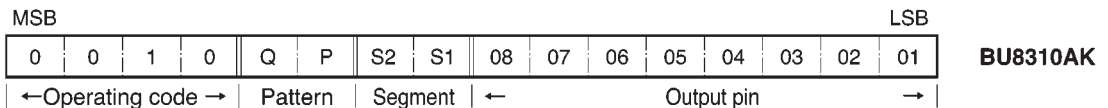

Note: The upper segment is Segment 1, and the lower segment is 2.

### (4) All LEDs valid command

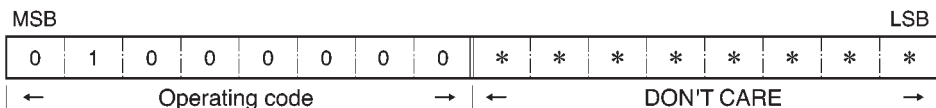

### (5) All LEDs invalid command



The contents of the D, P, and Q registers are held.



(6) Register reset command

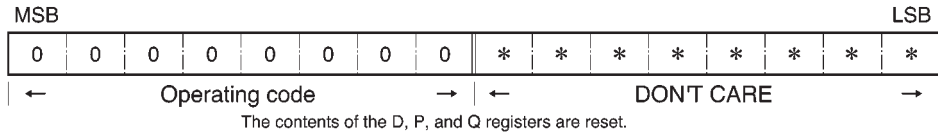

● Entering data settings

(1) Setting operands

S1~S4	These are used to select the segment. "1" selects a segment and "0" de-selects it. More than one segment can be selected at the same time. With pattern register writing, S3 and S4 are not used.
P, Q	These are used to specify the pattern. The lighted state, non-lighted state, and three different flashing patterns can be assigned independently to the 16 bits of segments 1 and 2.
01~08	These are used to select the output pin. "1" selects a pin and "0" de-selects it. More than one output pin can be selected at the same time.

(2) Setting the blink cycle

Q	P	Blink cycle (sec)	
		ON	OFF
0	0	Lighted	Lighted
1	0	0.5	0.5
0	1	1.0	1.0
1	1	0.125	0.125

● Driver internal equivalent circuit (for 1 bit)

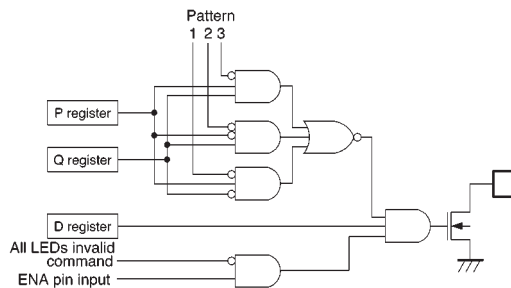
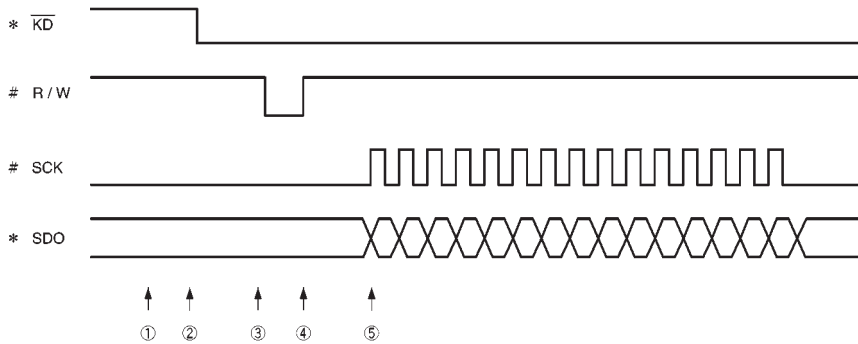

Fig. 3

● Recommended method for inputting/outputting data

(1) Serial output of key data

State	CPU Operation (#)	BU8310AK Series Operation (*)
①	At standby, R/W = HIGH, SCK = LOW	$\overline{KD}$ goes LOW when key is pressed. Serial data is output in sequential order.
②		
③	Supplied at falling edge of R/W (key data setting)	
④	R/W set to HIGH (read mode)	
⑤	SCK rising edges supplied in sequence	



(2) Serial input of LED control commands

State	CPU Operation #
①	At standby, R/W = HIGH, SCK = LOW
②	R/W set to LOW (write mode)
③	SDI input sequentially at rising edge of SCK.
④	After all 16-bit data has been input, R/W rising edge is supplied, and data is taken in internally.

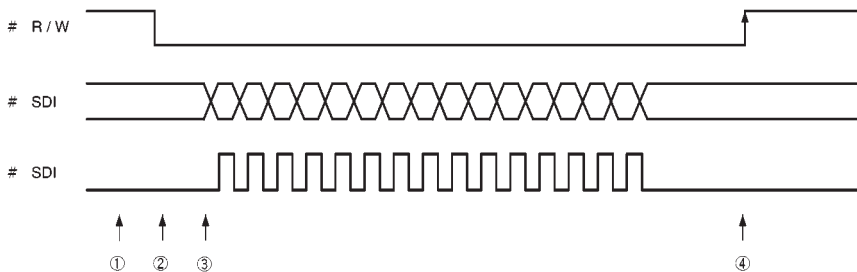

● Operation notes

(1) Serial output of key data when several keys are pressed at the same is as shown below.

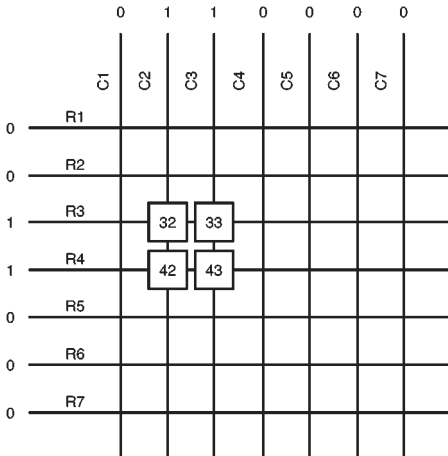

The key data when **32** and **43** are pressed at the same time will be the same as the key data when **33** and **42** are pressed at the same time.

(2) Pressing different keys

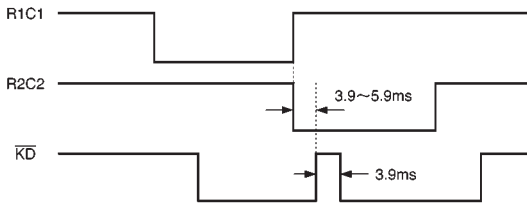

When a different key is pressed from the one already pressed,  $\overline{KD}$  is turned temporarily to provide notification of the change.

(3) When the power supply is turned on, the internal registers should be reset using either  $\overline{RST}$  pin input or the register reset command.

(4) If the  $\overline{RST}$  pin is set to LOW or the register reset command is executed while data is being output, the SDO output logic is not reset.

(5) If the D, P, and Q registers are rewritten, all eight bits should be written, and not just the pertinent bits.



(6) Operation states in response to  $\overline{RST}$ , KSCN and ENA pin input

Pin setting			BU8310AK series state			Usage examples
$\overline{RST}$	KSCN	ENA	Master oscillator	Key scan	LED output	
L	Does not matter		Stopped	Stopped	OFF	Power failure when on hook
H	L	L	Running	Normal operation	OFF	Power failure when off hook, or normal key scan
H	L	H	Running	Normal operation	ON	Power on, or normal key scan
H	H	L	Running	Runs when key is pressed	OFF	Power failure when off hook, or key pressed to start key scan
H	H	H	Running	Runs when key is pressed	ON	Power on, or key pressed to start key scan

● External dimensions (Units: mm)

