

Quad 2-input / 2-output analog switch

BU9761FS

The BU9761FS are analog switches with four circuits each, two for input and two for output. Depending on the status of the SELECT pin, the two input signals can be switched to either of two output pins. In addition, the EN pin can be used to set the output status to high impedance.

●Applications

Videos, movies, TVs, mini-component sets, radio cassette players, audio equipment, personal computers

●Features

- 1) Ultra-compact slim package. (SSOP-A20)
- 2) Low current dissipation. ($I_Q = 1\mu\text{A Max.}$)
- 3) Equipped with Output Enable terminal.
- 4) Low switching ON resistance. ($R_{ON} = 130\Omega$)
- 5) Low dispersion in switching ON resistance for the various channels. ($\Delta R_{ON} = 25\Omega \text{ Max.}$)

●Absolute maximum ratings ($T_a = 25^\circ\text{C}$)

Parameter	Symbol	Limits	Unit
Power supply voltage	V_{DD}	- 0.3 ~ + 7.0	V
Power dissipation	P_d	600*1	mW
Operating temperature	T_{opr}	- 25 ~ + 75	$^\circ\text{C}$
Storage temperature	T_{stg}	- 50 ~ + 150	$^\circ\text{C}$

*1 Reduced by 4.8mW for each increase in T_a of 1°C over 25°C .

●Recommended operating conditions ($T_a = 25^\circ\text{C}$)

Parameter	Symbol	Min.	Typ.	Max.	Unit
Power supply voltage	V_{DD}	4.0	5.0	6.0	V



●Block diagram

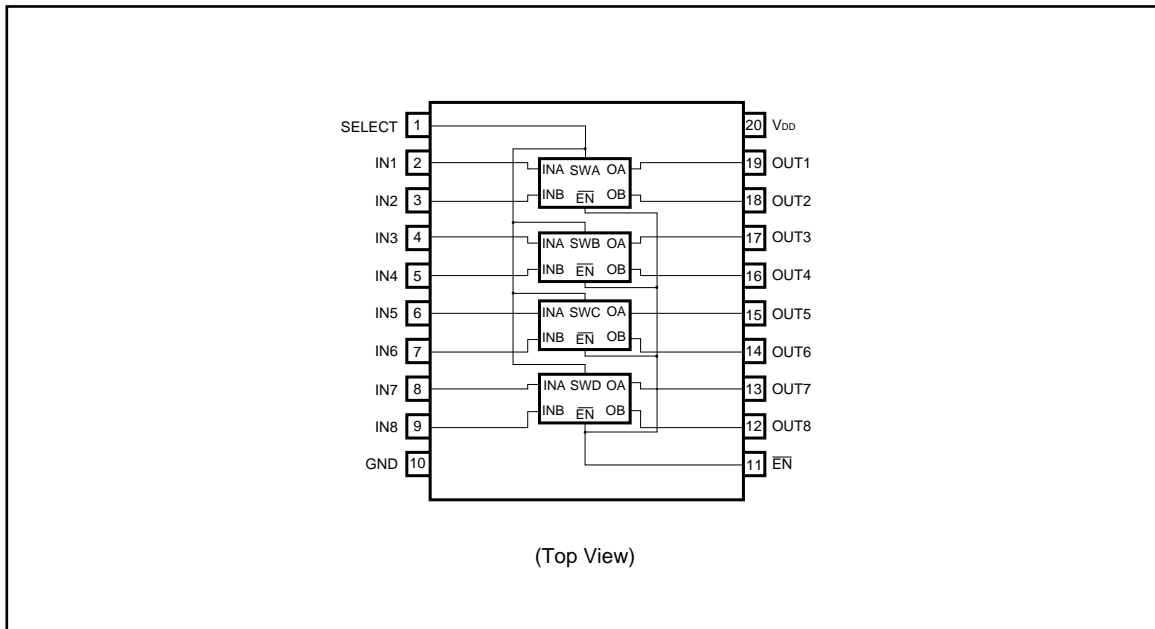

●Pin truth table

• \overline{EN}

\overline{EN}	H	L
OUT1 ~ 8	High-Z	Output Enable

• SELECT

H		L	
Input	Output	Input	Output
INA	OB	INA	OA
INB	OA	INB	OB

●DC characteristics (unless otherwise noted, Ta = 25°C, V_{DD} = 5 V)

Parameter	Symbol	Min.	Typ.	Max.	Unit	Conditions	Measurement circuit
Input high-level voltage	V _{IH}	3.5	—	—	V	R _L = 10kΩ	Fig.1
Input low-level voltage	V _{IL}	—	—	1.5	V	R _L = 10kΩ	Fig.1
Input high-level current	I _{IH}	—	—	0.3	μA	R _L = 10kΩ	Fig.1
Input low-level current	I _{IL}	—	—	0.3	μA	R _L = 10kΩ	Fig.1
ON resistance	R _{ON}	—	135	150	Ω	V _{IN} = V _{DD} / 2, R _L = 1kΩ	Fig.2
ON resistance deflexion	ΔR _{ON}	—	12	25	Ω	V _{IN} = V _{DD} / 2, R _L = 1kΩ	Fig.2
OFF-channel leakage current	I _{off}	—	—	0.3 - 0.3	μA	V _{IN} = 5V, V _{OUT} = 0V V _{IN} = 0V, V _{OUT} = 5V	Fig.3
Quiescent current	I _q	—	—	1.0	μA	V _{IN} = GND	—

●AC characteristics (unless otherwise noted, Ta = 25°C, V_{DD} = 5V, C_L = 50 pF, R_L = 10kΩ)

Parameter	Symbol	Min.	Typ.	Max.	Unit	V _{DD} (V)	Conditions	Measurement circuit
Propagation delay time IN to OUT	t _{PLH1}	—	40	—	ns	5	Output "L"→Output "H" Output "H"→Output "L"	Fig.4
	t _{PHL1}	—	40	—	ns	5		
Propagation delay time SELECT to OUT	t _{PLH2}	—	50	—	ns	5	Output "L"→Output "H" Output "H"→Output "L"	Fig.5
	t _{PHL2}	—	40	—	ns	5		
Output Enable time	t _{PHZ}	—	200	—	ns	5	Output "H"→Output "High Z" Output "L"→Output "High Z"	Fig.6 Fig.7
	t _{PLZ}	—	200	—	ns	5		
Output Disable time	t _{PZH}	—	50	—	ns	5	Output "High Z"→Output "H" Output "High Z"→Output "L"	Fig.6 Fig.7
	t _{PZL}	—	50	—	ns	5		
Input capacitance (control input)	C _C	—	35	—	pF	5	f = 1MHz	—
Input capacitance (switch input)	C _S	—	65	—	pF	5	f = 1MHz	—
Sine wave distortion (T.H.D.)	D	—	0.06	—	%	5	V _{IN} = 2.5V _{P-P} , f = 1kHz	Fig.8
Max. propagation frequency	f _{max}	—	1.15	—	MHz	5	V _{IN} = 2.5V _{P-P}	Fig.8
Feedthrough attenuation	FT	—	- 70	—	dB	5	V _{IN} = 2.5V _{P-P} , f = 10kHz	Fig.9
Crosstalk (control / switch)	CT _C	—	620	—	mV _{P-P}	5	f = 10kHz	Fig.10
Crosstalk between channels	CT	—	- 50	—	dB	5	V _{IN} = 2.5V _{P-P} , f = 10kHz	Fig.11

● Measurement circuits

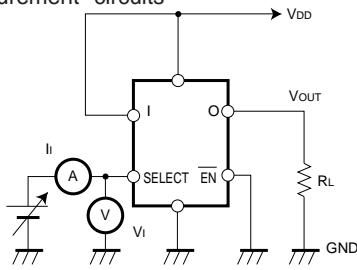

Fig.1 Input voltage, current

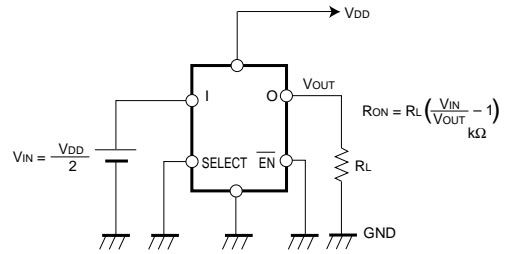

Fig.2 ON resistance, ON resistance deviation

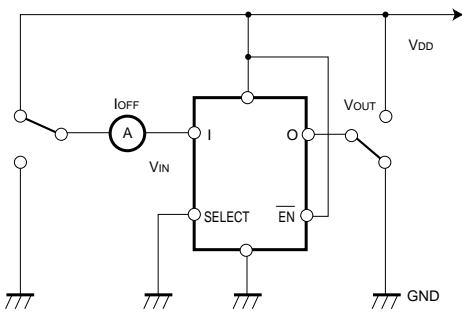

Fig.3 OFF-channel leakage current

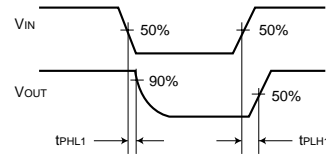
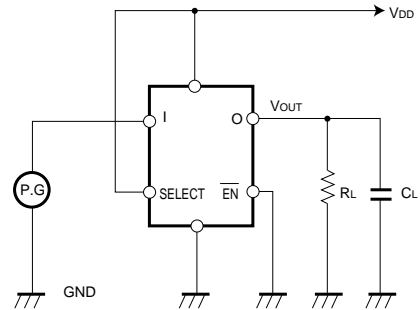

Fig.4 Propagation delay time (IN to OUT)

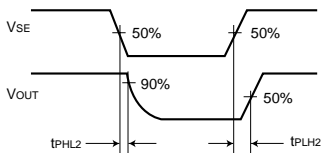
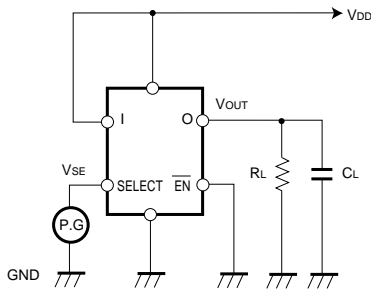

Fig.5 Propagation delay time (SELECT to OUT)

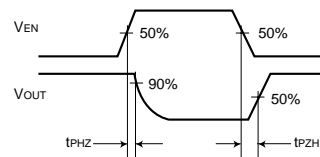
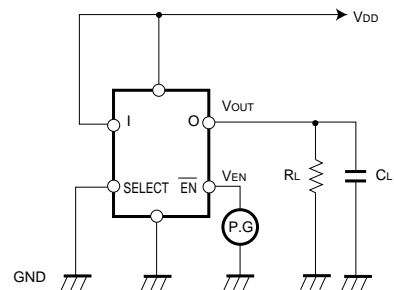

Fig.6 Output Enable, Disable time 1

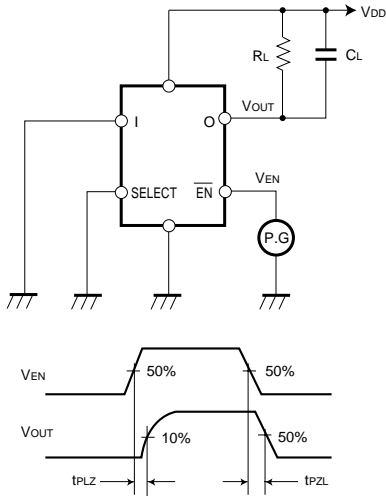

Fig.7 Output Enable, Disable time 2

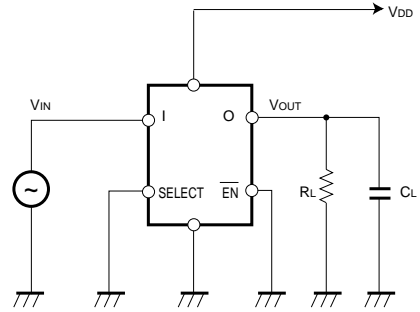

Fig.8 Sine wave distortion, maximum propagation frequency

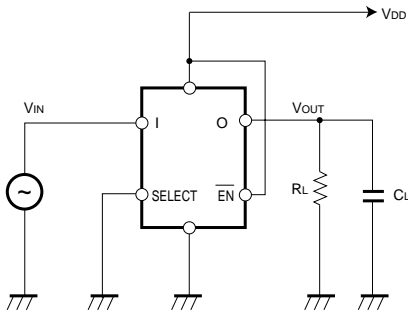

Fig.9 Feedthrough attenuation

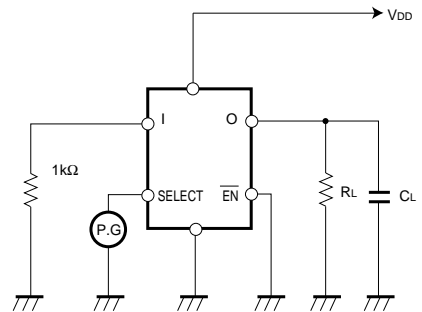

Fig.10 Crosstalk (between control switches)

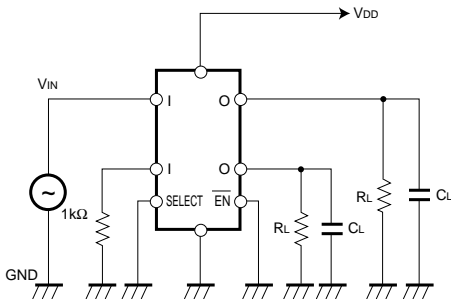

Fig. 11 Crosstalk

●Electrical characteristic curve

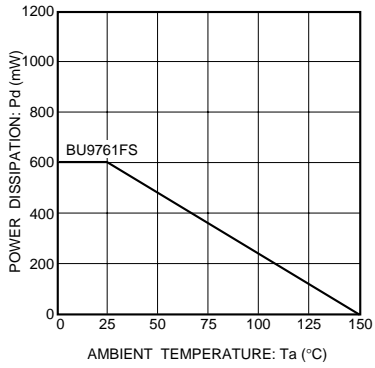

Fig.12 Power dissipation vs. ambient temperature

●External dimensions (Units: mm)

