



BUF410

HIGH VOLTAGE FAST-SWITCHING NPN POWER TRANSISTOR

- SGS-THOMSON PREFERRED SALESTYPE
- HIGH VOLTAGE CAPABILITY
- VERY HIGH SWITCHING SPEED
- MINIMUM LOT-TO-LOT SPREAD FOR RELIABLE OPERATION
- LOW BASE-DRIVE REQUIREMENTS

APPLICATIONS:

- SWITCH MODE POWER SUPPLIES
- MOTOR CONTROL

DESCRIPTION

The BUF410 is manufactured using High Voltage Multi Epitaxial Planar technology for high switching speeds and high voltage capacity. They use a Cellular Emitter structure with planar edge termination to enhance switching speeds while maintaining a wide RBSOA.

The BUF series is designed for use in high-frequency power supplies and motor control applications.

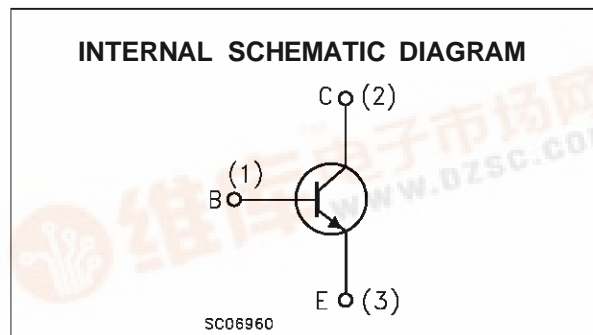
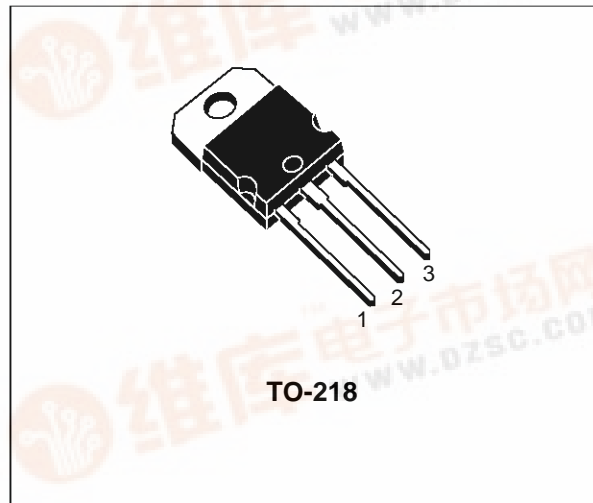

ABSOLUTE MAXIMUM RATINGS

Symbol	Parameter	Value	Unit
V_{CEV}	Collector-Emitter Voltage ($V_{BE} = -1.5\text{ V}$)	850	V
V_{CEO}	Collector-Emitter Voltage ($I_B = 0$)	450	V
V_{EBO}	Emitter-Base Voltage ($I_C = 0$)	7	V
I_C	Collector Current	15	A
I_{CM}	Collector Peak Current ($t_p < 5\text{ ms}$)	30	A
I_B	Base Current	3	A
I_{BM}	Base Peak Current ($t_p < 5\text{ ms}$)	4.5	A
P_{tot}	Total Dissipation at $T_c = 25\text{ }^\circ\text{C}$	125	W
T_{stg}	Storage Temperature	-65 to 150	$^\circ\text{C}$
T_j	Max Operation Junction Temperature	150	$^\circ\text{C}$
T_j	Max. Operating Junction Temperature	150	$^\circ\text{C}$

BUF410

THERMAL DATA

$R_{thj-case}$	Thermal Resistance Junction-Case	Max	1	$^{\circ}\text{C}/\text{W}$
----------------	----------------------------------	-----	---	-----------------------------

ELECTRICAL CHARACTERISTICS ($T_{case} = 25^{\circ}\text{C}$ unless otherwise specified)

Symbol	Parameter	Test Conditions	Min.	Typ.	Max.	Unit
I_{CER}	Collector Cut-off Current ($R_{BE} = 100 \Omega$)	$V_{CE} = V_{CEV}$ $V_{CE} = V_{CEV} \quad T_c = 100^{\circ}\text{C}$			0.2 1	mA mA
I_{CEV}	Collector Cut-off Current ($I_B = 0$)	$V_{CE} = V_{CEV} \quad V_{BE} = -1.5 \text{ V}$ $V_{CE} = V_{CEV} \quad V_{BE} = -1.5 \text{ V} \quad T_c = 100^{\circ}\text{C}$			0.2 1	mA mA
I_{EBO}	Emitter Cut-off Current ($I_C = 0$)	$V_{BE} = 5 \text{ V}$			1	mA
$V_{CEO(sus)}^*$	Collector-Emitter Sustaining Voltage	$I_C = 200 \text{ mA} \quad L = 25 \text{ mH}$	450			V
V_{EBO}	Emitter Base Voltage ($I_C = 0$)	$I_E = 50 \text{ mA}$	7			V
$V_{CE(sat)}^*$	Collector-Emitter Saturation Voltage	$I_C = 5 \text{ A} \quad I_B = 0.5 \text{ A}$ $I_C = 5 \text{ A} \quad I_B = 0.5 \text{ A} \quad T_c = 100^{\circ}\text{C}$ $I_C = 10 \text{ A} \quad I_B = 2 \text{ A}$ $I_C = 10 \text{ A} \quad I_B = 2 \text{ A} \quad T_c = 100^{\circ}\text{C}$		0.8 0.5	2.8 2	V V V V
$V_{BE(sat)}^*$	Base-Emitter Saturation Voltage	$I_C = 5 \text{ A} \quad I_B = 0.5 \text{ A}$ $I_C = 5 \text{ A} \quad I_B = 0.5 \text{ A} \quad T_c = 100^{\circ}\text{C}$ $I_C = 10 \text{ A} \quad I_B = 2 \text{ A}$ $I_C = 10 \text{ A} \quad I_B = 2 \text{ A} \quad T_c = 100^{\circ}\text{C}$		0.9 1.1	1.5 1.5	V V V V
di_c/dt	Rate of rise on-state Collector Current	$V_{CC} = 300 \text{ V} \quad R_C = 0 \quad t_p = 3 \mu\text{s}$ $I_{B1} = 0.75 \text{ A} \quad T_j = 25^{\circ}\text{C}$ $I_{B1} = 0.75 \text{ A} \quad T_j = 100^{\circ}\text{C}$ $I_{B1} = 3 \text{ A} \quad T_j = 100^{\circ}\text{C}$	45 100	60		$\text{A}/\mu\text{s}$ $\text{A}/\mu\text{s}$ $\text{A}/\mu\text{s}$
$V_{CE(3\mu\text{s})}$	Collector-Emitter Dynamic Voltage	$V_{CC} = 300 \text{ V} \quad R_C = 60 \Omega$ $I_{B1} = 0.75 \text{ A} \quad T_j = 25^{\circ}\text{C}$ $I_{B1} = 0.75 \text{ A} \quad T_j = 100^{\circ}\text{C}$		2.1	8	V V
$V_{CE(5\mu\text{s})}$	Collector-Emitter Dynamic Voltage	$V_{CC} = 300 \text{ V} \quad R_C = 60 \Omega$ $I_{B1} = 0.75 \text{ A} \quad T_j = 25^{\circ}\text{C}$ $I_{B1} = 0.75 \text{ A} \quad T_j = 100^{\circ}\text{C}$		1.1	4	V V
t_s t_f t_c	Storage Time Fall Time Cross Over Time	$I_C = 5 \text{ A} \quad V_{CC} = 50 \text{ V}$ $V_{BB} = -5 \text{ V} \quad R_{BB} = 1.2 \Omega$ $V_{clamp} = 400 \text{ V} \quad I_{B1} = 0.5 \text{ A}$ $L = 0.5 \text{ mH}$		0.8 0.05 0.08		μs μs μs
t_s t_f t_c	Storage Time Fall Time Cross Over Time	$I_C = 5 \text{ A} \quad V_{CC} = 50 \text{ V}$ $V_{BB} = -5 \text{ V} \quad R_{BB} = 1.2 \Omega$ $V_{clamp} = 400 \text{ V} \quad I_{B1} = 0.5 \text{ A}$ $L = 0.5 \text{ mH} \quad T_j = 100^{\circ}\text{C}$			1.8 0.1 0.18	μs μs μs
V_{CEW}	Maximum Collector Emitter Voltage without Snubber	$I_C = 5 \text{ A} \quad V_{CC} = 50 \text{ V}$ $V_{BB} = -5 \text{ V} \quad R_{BB} = 1.2 \Omega$ $V_{clamp} = 400 \text{ V} \quad I_{B1} = 0.5 \text{ A}$ $L = 0.5 \text{ mH} \quad T_j = 125^{\circ}\text{C}$	500			V
t_s t_f t_c	Storage Time Fall Time Cross Over Time	$I_C = 5 \text{ A} \quad V_{CC} = 50 \text{ V}$ $V_{BB} = 0 \quad R_{BB} = 0.3 \Omega$ $V_{clamp} = 400 \text{ V} \quad I_{B1} = 0.5 \text{ A}$ $L = 0.5 \text{ mH}$		1.5 0.04 0.07		μs μs μs

ELECTRICAL CHARACTERISTICS (continued)

Symbol	Parameter	Test Conditions		Min.	Typ.	Max.	Unit
t_s t_f t_c	Storage Time Fall Time Cross Over Time	$I_C = 5\text{ A}$ $V_{BB} = 0$ $V_{clamp} = 400\text{ V}$ $L = 0.5\text{ mH}$	$V_{CC} = 50\text{ V}$ $R_{BB} = 0.3\ \Omega$ $I_{B1} = 0.5\text{ A}$ $T_J = 100^\circ\text{C}$			3 0.15 0.25	μs μs μs
V_{CEW}	Maximum Collector Emitter Voltage without Snubber	$I_C = 5\text{ A}$ $V_{BB} = 0$ $V_{clamp} = 400\text{ V}$ $L = 0.5\text{ mH}$	$V_{CC} = 50\text{ V}$ $R_{BB} = 0.3\ \Omega$ $I_{B1} = 0.5\text{ A}$ $T_J = 125^\circ\text{C}$	500			V
t_s t_f t_c	Storage Time Fall Time Cross Over Time	$I_C = 10\text{ A}$ $V_{BB} = -5\text{ V}$ $V_{clamp} = 400\text{ V}$ $L = 0.25\text{ mH}$	$V_{CC} = 50\text{ V}$ $R_{BB} = 1.2\ \Omega$ $I_{B1} = 2\text{ A}$		1.9 0.06 0.12		μs μs μs
t_s t_f t_c	Storage Time Fall Time Cross Over Time	$I_C = 10\text{ A}$ $V_{BB} = -5\text{ V}$ $V_{clamp} = 400\text{ V}$ $L = 0.25\text{ mH}$	$V_{CC} = 50\text{ V}$ $R_{BB} = 1.2\ \Omega$ $I_{B1} = 2\text{ A}$ $T_J = 100^\circ\text{C}$			3.2 0.12 0.3	μs μs μs
V_{CEW}	Maximum Collector Emitter Voltage without Snubber	$I_{C\text{Woff}} = 15\text{ A}$ $V_{BB} = -5\text{ V}$ $L = 0.17\text{ mH}$ $T_J = 125^\circ\text{C}$	$V_{CC} = 50\text{ V}$ $R_{BB} = 1.2\ \Omega$ $I_{B1} = 3\text{ A}$	400			V

Turn-on Switching Test Circuit

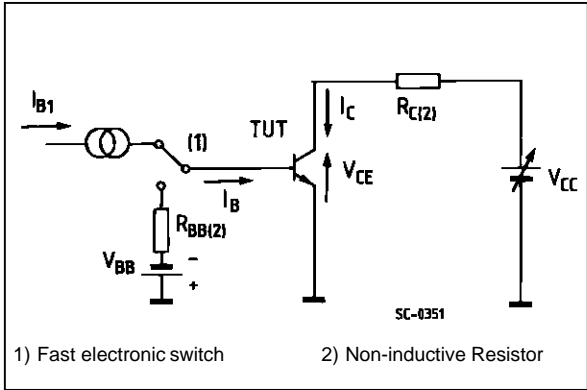

Turn-off Switching Test Circuit

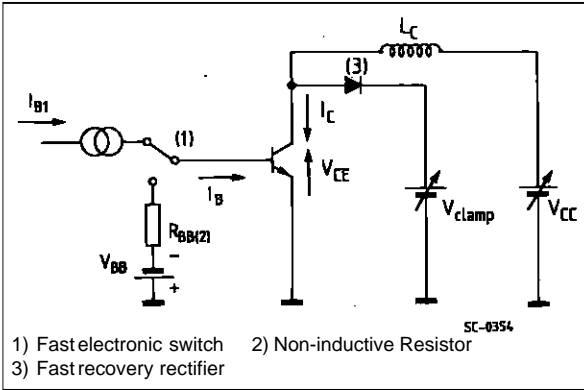

Turn-on Switching Test Waveforms.

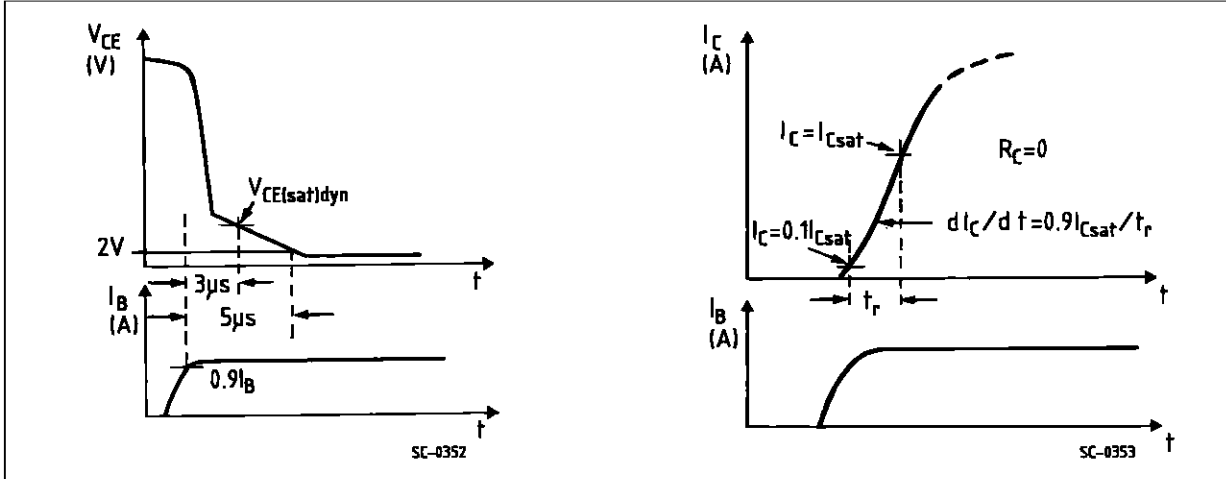

BUF410

Turn-off Switching Test Waveforms (inductive load). Forward Biased Safe Operating Areas.

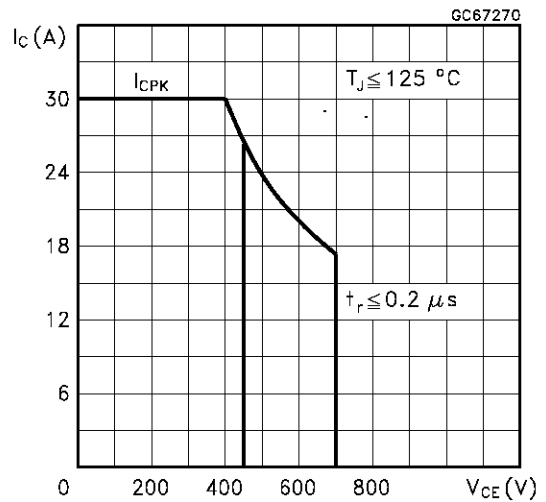
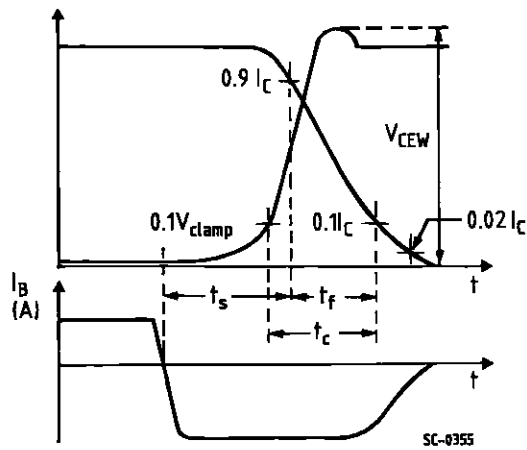

Reverse Biased Safe Operating Area

Storage Time Versus Pulse Time.

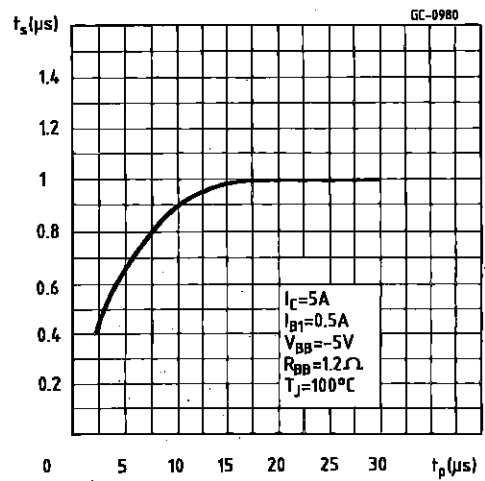
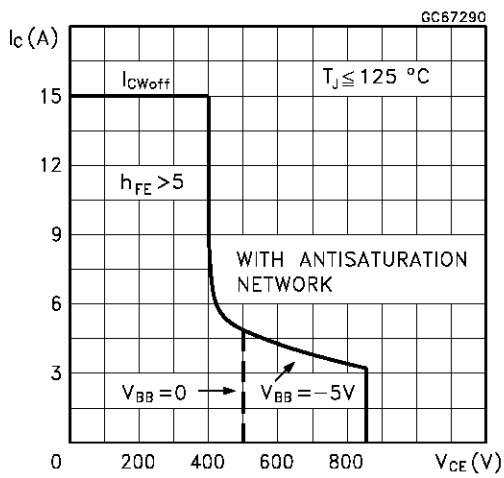

TO-218 (SOT-93) MECHANICAL DATA

DIM.	mm			inch		
	MIN.	TYP.	MAX.	MIN.	TYP.	MAX.
A	4.7		4.9	0.185		0.193
C	1.17		1.37	0.046		0.054
D		2.5			0.098	
E	0.5		0.78	0.019		0.030
F	1.1		1.3	0.043		0.051
G	10.8		11.1	0.425		0.437
H	14.7		15.2	0.578		0.598
L2	-		16.2	-		0.637
L3		18			0.708	
L5	3.95		4.15	0.155		0.163
L6		31			1.220	
R	-		12.2	-		0.480
Ø	4		4.1	0.157		0.161

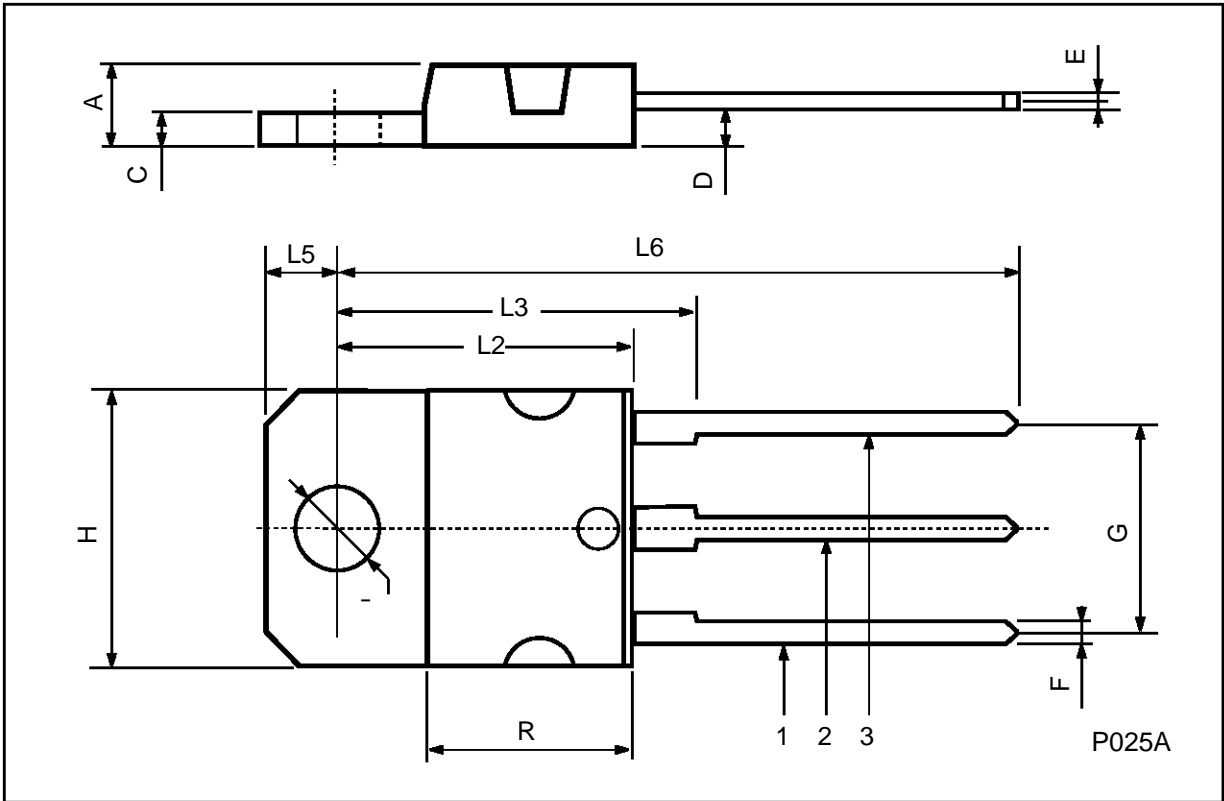

Information furnished is believed to be accurate and reliable. However, SGS-THOMSON Microelectronics assumes no responsibility for the consequences of use of such information nor for any infringement of patents or other rights of third parties which may result from its use. No license is granted by implication or otherwise under any patent or patent rights of SGS-THOMSON Microelectronics. Specifications mentioned in this publication are subject to change without notice. This publication supersedes and replaces all information previously supplied. SGS-THOMSON Microelectronics products are not authorized for use as critical components in life support devices or systems without express written approval of SGS-THOMSON Microelectronics.

© 1997 SGS-THOMSON Microelectronics - Printed in Italy - All Rights Reserved

SGS-THOMSON Microelectronics GROUP OF COMPANIES

Australia - Brazil - Canada - China - France - Germany - Hong Kong - Italy - Japan - Korea - Malaysia - Malta - Morocco - The Netherlands - Singapore - Spain - Sweden - Switzerland - Taiwan - Thailand - United Kingdom - U.S.A

...