



# BUF410A

## HIGH VOLTAGE FAST-SWITCHING NPN POWER TRANSISTOR

- SGS-THOMSON PREFERRED SALESTYPE
- HIGH VOLTAGE CAPABILITY
- VERY HIGH SWITCHING SPEED
- MINIMUM LOT-TO-LOT SPREAD FOR RELIABLE OPERATION
- LOW BASE-DRIVE REQUIREMENTS

**APPLICATIONS:**

- SWITCH MODE POWER SUPPLIES
- MOTOR CONTROL

**DESCRIPTION**

The BUF410A is manufactured using High Voltage Multi Epitaxial Planar technology for high switching speeds and high voltage capacity. They use a Cellular Emitter structure with planar edge termination to enhance switching speeds while maintaining a wide RBSOA.

The BUF series is designed for use in high-frequency power supplies and motor control applications.

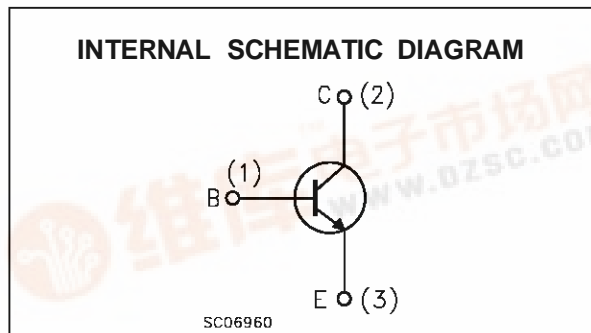
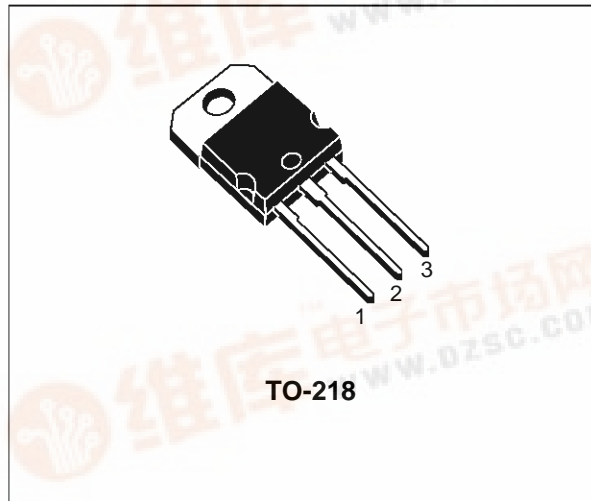

**ABSOLUTE MAXIMUM RATINGS**

Symbol	Parameter	Value	Unit
$V_{CEV}$	Collector-Emitter Voltage ( $V_{BE} = -1.5\text{ V}$ )	1000	V
$V_{CEO}$	Collector-Emitter Voltage ( $I_B = 0$ )	450	V
$V_{EBO}$	Emitter-Base Voltage ( $I_C = 0$ )	7	V
$I_C$	Collector Current	15	A
$I_{CM}$	Collector Peak Current ( $t_p < 5\text{ ms}$ )	30	A
$I_B$	Base Current	3	A
$I_{BM}$	Base Peak Current ( $t_p < 5\text{ ms}$ )	4.5	A
$P_{tot}$	Total Dissipation at $T_c = 25\text{ }^\circ\text{C}$	125	W
$T_{stg}$	Storage Temperature	-65 to 150	$^\circ\text{C}$
$T_j$	Max Operation Junction Temperature	150	$^\circ\text{C}$



## BUF410A

### THERMAL DATA

$R_{thj-case}$	Thermal Resistance Junction-Case	Max	1	°C/W
----------------	----------------------------------	-----	---	------

### ELECTRICAL CHARACTERISTICS ( $T_{case} = 25\text{ °C}$ unless otherwise specified)

Symbol	Parameter	Test Conditions	Min.	Typ.	Max.	Unit
$I_{CER}$	Collector Cut-off Current ( $R_{BE} = 100\ \Omega$ )	$V_{CE} = V_{CEV}$ $V_{CE} = V_{CEV}$ $T_c = 100\text{ °C}$			0.2 1	mA mA
$I_{CEV}$	Collector Cut-off Current ( $I_B = 0$ )	$V_{CE} = V_{CEV}$ $V_{BE} = -1.5\text{ V}$ $V_{CE} = V_{CEV}$ $V_{BE} = -1.5\text{ V}$ $T_c = 100\text{ °C}$			0.2 1	mA mA
$I_{EBO}$	Emitter Cut-off Current ( $I_C = 0$ )	$V_{BE} = 5\text{ V}$			1	mA
$V_{CEO(sus)*}$	Collector-Emitter Sustaining Voltage	$I_C = 200\text{ mA}$ $L = 25\text{ mH}$	450			V
$V_{EBO}$	Emitter Base Voltage ( $I_C = 0$ )	$I_E = 50\text{ mA}$	7			V
$V_{CE(sat)*}$	Collector-Emitter Saturation Voltage	$I_C = 5\text{ A}$ $I_B = 0.5\text{ A}$ $I_C = 5\text{ A}$ $I_B = 0.5\text{ A}$ $T_c = 100\text{ °C}$ $I_C = 10\text{ A}$ $I_B = 2\text{ A}$ $I_C = 10\text{ A}$ $I_B = 2\text{ A}$ $T_c = 100\text{ °C}$		0.8 0.5	2.8 2	V V V V
$V_{BE(sat)*}$	Base-Emitter Saturation Voltage	$I_C = 5\text{ A}$ $I_B = 0.5\text{ A}$ $I_C = 5\text{ A}$ $I_B = 0.5\text{ A}$ $T_c = 100\text{ °C}$ $I_C = 10\text{ A}$ $I_B = 2\text{ A}$ $I_C = 10\text{ A}$ $I_B = 2\text{ A}$ $T_c = 100\text{ °C}$		0.9 1.1	1.5 1.5	V V V V
$di_c/dt$	Rate of rise on-state Collector Current	$V_{CC} = 300\text{ V}$ $R_C = 0$ $t_p = 3\ \mu s$ $I_{B1} = 0.75\text{ A}$ $T_j = 25\text{ °C}$ $I_{B1} = 0.75\text{ A}$ $T_j = 100\text{ °C}$ $I_{B1} = 3\text{ A}$ $T_j = 100\text{ °C}$	45 100	60		A/ $\mu s$ A/ $\mu s$ A/ $\mu s$
$V_{CE(3\mu s)}$	Collector-Emitter Dynamic Voltage	$V_{CC} = 300\text{ V}$ $R_C = 60\ \Omega$ $I_{B1} = 0.75\text{ A}$ $T_j = 25\text{ °C}$ $I_{B1} = 0.75\text{ A}$ $T_j = 100\text{ °C}$		2.1	8	V V
$V_{CE(5\mu s)}$	Collector-Emitter Dynamic Voltage	$V_{CC} = 300\text{ V}$ $R_C = 60\ \Omega$ $I_{B1} = 0.75\text{ A}$ $T_j = 25\text{ °C}$ $I_{B1} = 0.75\text{ A}$ $T_j = 100\text{ °C}$		1.1	4	V V
$t_s$ $t_f$ $t_c$	Storage Time Fall Time Cross Over Time	$I_C = 5\text{ A}$ $V_{CC} = 50\text{ V}$ $V_{BB} = -5\text{ V}$ $R_{BB} = 1.2\ \Omega$ $V_{clamp} = 400\text{ V}$ $I_{B1} = 0.5\text{ A}$ $L = 0.5\text{ mH}$		0.8 0.05 0.08		$\mu s$ $\mu s$ $\mu s$
$t_s$ $t_f$ $t_c$	Storage Time Fall Time Cross Over Time	$I_C = 5\text{ A}$ $V_{CC} = 50\text{ V}$ $V_{BB} = -5\text{ V}$ $R_{BB} = 1.2\ \Omega$ $V_{clamp} = 400\text{ V}$ $I_{B1} = 0.5\text{ A}$ $L = 0.5\text{ mH}$ $T_j = 100\text{ °C}$			1.8 0.1 0.18	$\mu s$ $\mu s$ $\mu s$
$V_{CEW}$	Maximum Collector Emitter Voltage without Snubber	$I_C = 5\text{ A}$ $V_{CC} = 50\text{ V}$ $V_{BB} = -5\text{ V}$ $R_{BB} = 1.2\ \Omega$ $V_{clamp} = 400\text{ V}$ $I_{B1} = 0.5\text{ A}$ $L = 0.5\text{ mH}$ $T_j = 125\text{ °C}$	500			V
$t_s$ $t_f$ $t_c$	Storage Time Fall Time Cross Over Time	$I_C = 5\text{ A}$ $V_{CC} = 50\text{ V}$ $V_{BB} = 0$ $R_{BB} = 0.3\ \Omega$ $V_{clamp} = 400\text{ V}$ $I_{B1} = 0.5\text{ A}$ $L = 0.5\text{ mH}$		1.5 0.04 0.07		$\mu s$ $\mu s$ $\mu s$

ELECTRICAL CHARACTERISTICS (continued)

Symbol	Parameter	Test Conditions	Min.	Typ.	Max.	Unit
$t_s$ $t_f$ $t_c$	Storage Time Fall Time Cross Over Time	$I_C = 5\text{ A}$ $V_{BB} = 0$ $V_{clamp} = 400\text{ V}$ $L = 0.5\text{ mH}$	$V_{CC} = 50\text{ V}$ $R_{BB} = 0.3\ \Omega$ $I_{B1} = 0.5\text{ A}$ $T_j = 100^\circ\text{C}$		3 0.15 0.25	$\mu\text{s}$ $\mu\text{s}$ $\mu\text{s}$
$V_{CEW}$	Maximum Collector Emitter Voltage without Snubber	$I_C = 5\text{ A}$ $V_{BB} = 0$ $V_{clamp} = 400\text{ V}$ $L = 0.5\text{ mH}$	$V_{CC} = 50\text{ V}$ $R_{BB} = 0.3\ \Omega$ $I_{B1} = 0.5\text{ A}$ $T_j = 125^\circ\text{C}$	500		V
$t_s$ $t_f$ $t_c$	Storage Time Fall Time Cross Over Time	$I_C = 10\text{ A}$ $V_{BB} = -5\text{ V}$ $V_{clamp} = 400\text{ V}$ $L = 0.25\text{ mH}$	$V_{CC} = 50\text{ V}$ $R_{BB} = 1.2\ \Omega$ $I_{B1} = 2\text{ A}$		1.9 0.06 0.12	$\mu\text{s}$ $\mu\text{s}$ $\mu\text{s}$
$t_s$ $t_f$ $t_c$	Storage Time Fall Time Cross Over Time	$I_C = 10\text{ A}$ $V_{BB} = -5\text{ V}$ $V_{clamp} = 400\text{ V}$ $L = 0.25\text{ mH}$	$V_{CC} = 50\text{ V}$ $R_{BB} = 1.2\ \Omega$ $I_{B1} = 2\text{ A}$ $T_j = 100^\circ\text{C}$		3.2 0.12 0.3	$\mu\text{s}$ $\mu\text{s}$ $\mu\text{s}$
$V_{CEW}$	Maximum Collector Emitter Voltage without Snubber	$I_{C\text{Woff}} = 15\text{ A}$ $V_{BB} = -5\text{ V}$ $L = 0.17\text{ mH}$ $T_j = 125^\circ\text{C}$	$V_{CC} = 50\text{ V}$ $R_{BB} = 1.2\ \Omega$ $I_{B1} = 3\text{ A}$	400		V

Turn-on Switching Test Circuit

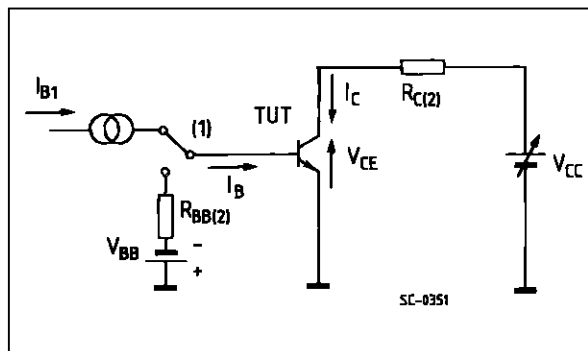

Turn-off Switching Test Circuit

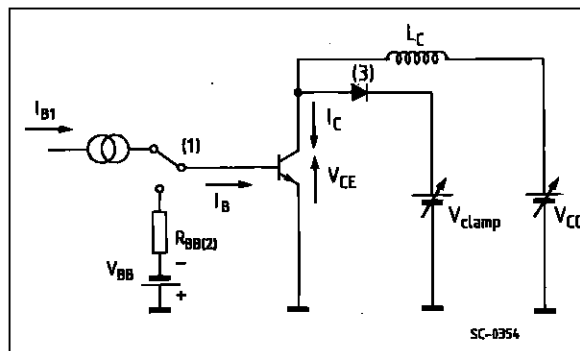

Turn-on Switching Test Waveforms.

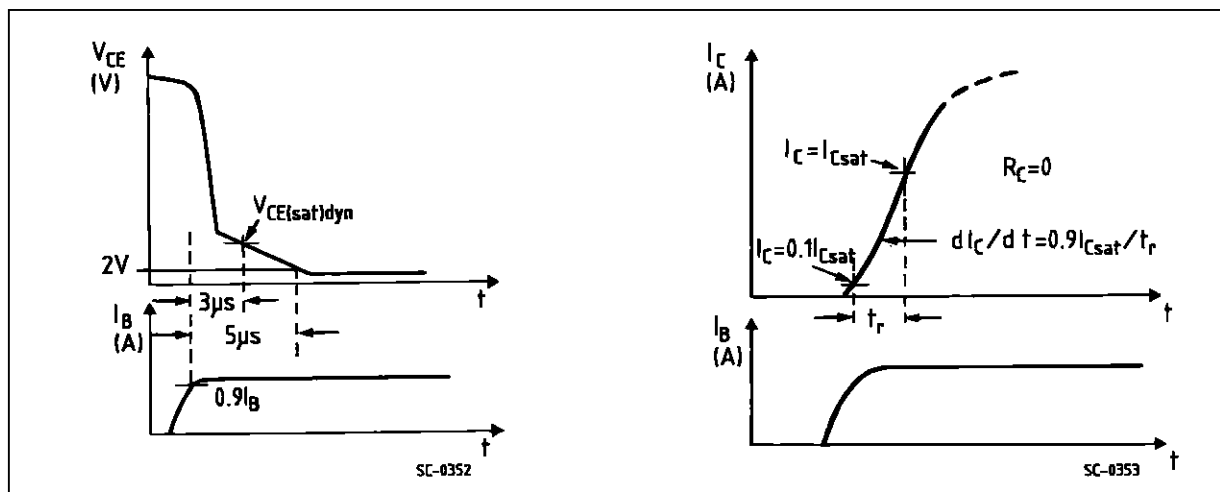

# BUF410A

Turn-off Switching Test Waveforms (inductive load). Forward Biased Safe Operating Areas.

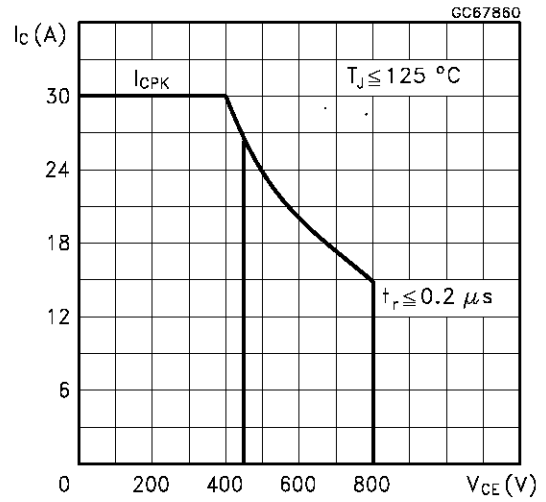
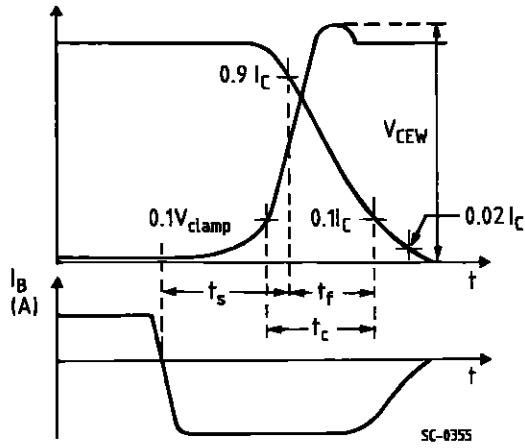

Reverse Biased Safe Operating Area

Storage Time Versus Pulse Time.

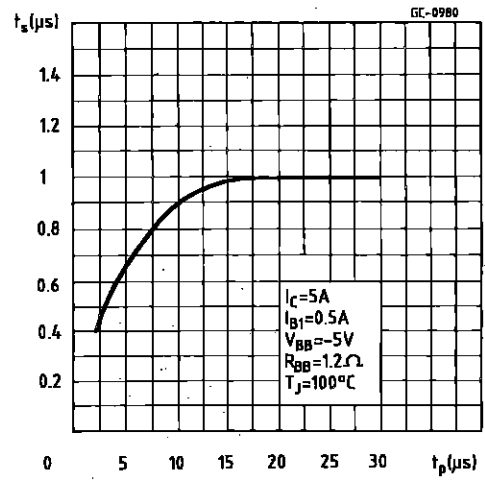
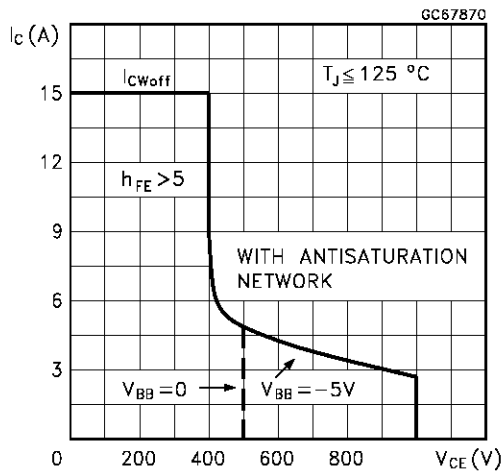

**TO-218 (SOT-93) MECHANICAL DATA**

DIM.	mm			inch		
	MIN.	TYP.	MAX.	MIN.	TYP.	MAX.
A	4.7		4.9	0.185		0.193
C	1.17		1.37	0.046		0.054
D		2.5			0.098	
E	0.5		0.78	0.019		0.030
F	1.1		1.3	0.043		0.051
G	10.8		11.1	0.425		0.437
H	14.7		15.2	0.578		0.598
L2	-		16.2	-		0.637
L3		18			0.708	
L5	3.95		4.15	0.155		0.163
L6		31			1.220	
R	-		12.2	-		0.480
Ø	4		4.1	0.157		0.161

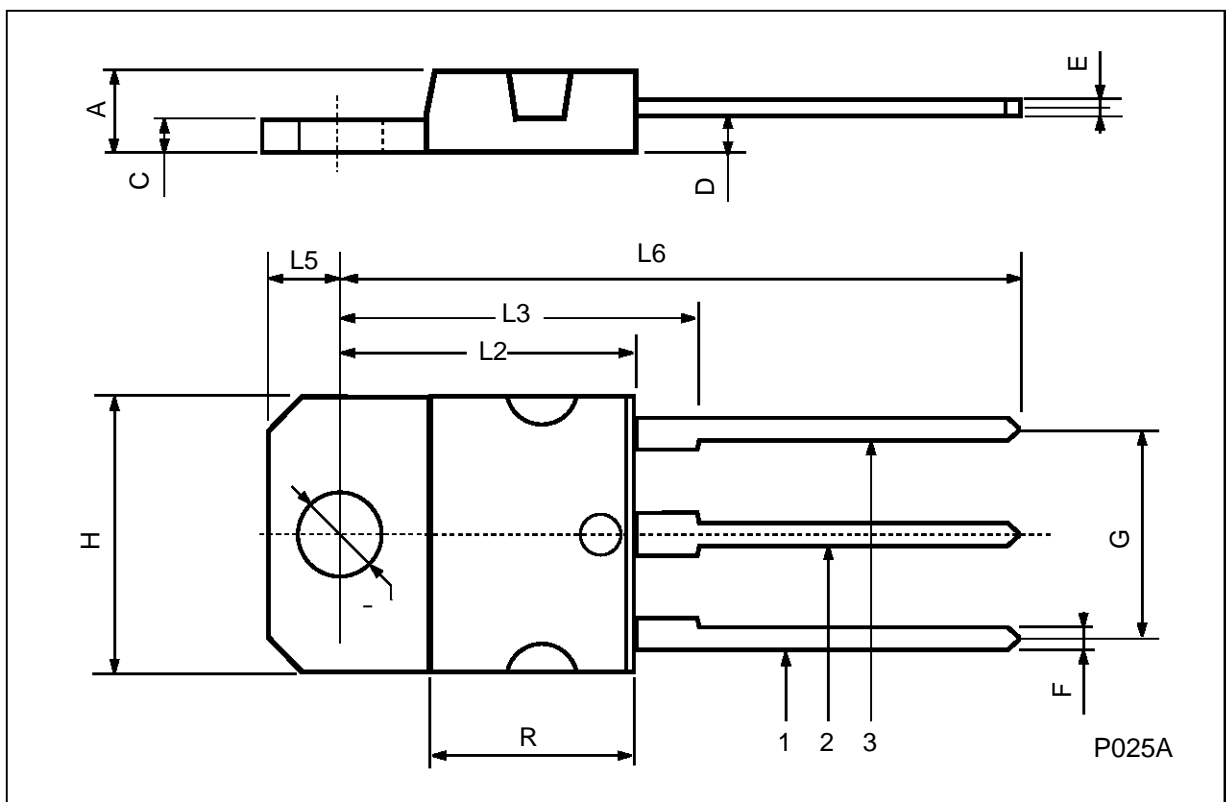

Information furnished is believed to be accurate and reliable. However, SGS-THOMSON Microelectronics assumes no responsibility for the consequences of use of such information nor for any infringement of patents or other rights of third parties which may result from its use. No license is granted by implication or otherwise under any patent or patent rights of SGS-THOMSON Microelectronics. Specifications mentioned in this publication are subject to change without notice. This publication supersedes and replaces all information previously supplied. SGS-THOMSON Microelectronics products are not authorized for use as critical components in life support devices or systems without express written approval of SGS-THOMSON Microelectronics.

© 1995 SGS-THOMSON Microelectronics - Printed in Italy - All Rights Reserved

SGS-THOMSON Microelectronics GROUP OF COMPANIES  
Australia - Brazil - Canada - China - France - Germany - Hong Kong - Italy - Japan - Korea - Malaysia - Malta - Morocco - The Netherlands -  
Singapore - Spain - Sweden - Switzerland - Taiwan - Thailand - United Kingdom - U.S.A