

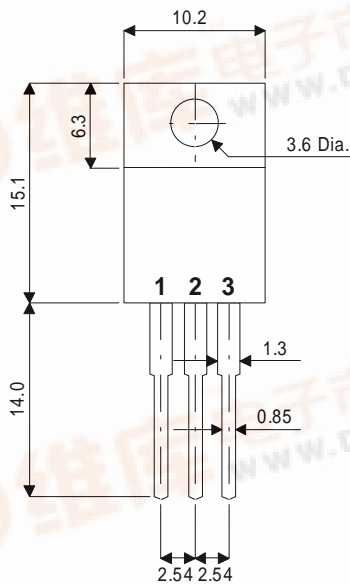

BUL52BFI

MECHANICAL DATA

Dimensions in mm



ISOLATED TO220

Pin 1 – Base Pin 2 – Collector Pin 3 – Emitter

**ADVANCED
DISTRIBUTED BASE DESIGN
HIGH VOLTAGE
HIGH SPEED NPN
SILICON POWER TRANSISTOR**

Designed for use in
electronic ballast applications

- SEMEFAB DESIGNED AND DIFFUSED DIE
- HIGH VOLTAGE
- FAST SWITCHING
- HIGH ENERGY RATING

FEATURES

- Multi-base for efficient energy distribution across the chip resulting in significantly improved switching and energy ratings across full temperature range.
- Ion implant and high accuracy masking for tight control of characteristics from batch to batch.
- Triple Guard Rings for improved control of high voltages.

ABSOLUTE MAXIMUM RATINGS ($T_{case} = 25^{\circ}C$ unless otherwise stated)

V_{CBO}	Collector – Base Voltage	800V
V_{CEO}	Collector – Emitter Voltage ($I_B = 0$)	400V
V_{EBO}	Emitter – Base Voltage ($I_C = 0$)	10V
I_C	Continuous Collector Current	8A
$I_{C(PK)}$	Peak Collector Current	12A
I_B	Base Current	4A
P_{tot}	Total Dissipation at $T_{case} = 25^{\circ}C$	45W
T_{stg}	Operating and Storage Temperature Range	-55 to +150°C



ELECTRICAL CHARACTERISTICS ($T_{case} = 25^{\circ}C$ unless otherwise stated)

Parameter	Test Conditions	Min.	Typ.	Max.	Unit	
ELECTRICAL CHARACTERISTICS						
$V_{CEO(sus)}$	Collector – Emitter Sustaining Voltage	$I_C = 10mA$	400			
$V_{(BR)CBO}$	Collector – Base Breakdown Voltage	$I_C = 1mA$	800		V	
$V_{(BR)EBO}$	Emitter – Base Breakdown Voltage	$I_E = 1mA$	10			
I_{CBO}	Collector – Base Cut-Off Current	$V_{CB} = 800V$			10	
			$T_C = 125^{\circ}C$		100	μA
I_{CEO}	Collector – Emitter Cut-Off Current	$I_B = 0$	$V_{CE} = 400V$		100	μA
I_{EBO}	Emitter Cut-Off Current	$V_{EB} = 9V$	$I_C = 0$		10	
				$T_C = 125^{\circ}C$		100
h_{FE}^*	DC Current Gain	$I_C = 100mA$	$V_{CE} = 5V$	20	30	
				$I_C = 1A$	$V_{CE} = 5V$	15
		$I_C = 3A$	$V_{CE} = 1V$	9	15	
				$T_C = 125^{\circ}C$	5	
$V_{CE(sat)}^*$	Collector – Emitter Saturation Voltage	$I_C = 100mA$	$I_B = 20mA$		0.05	0.1
				$I_C = 1A$	$I_B = 0.2A$	
		$I_C = 2A$	$I_B = 0.4A$		0.15	0.3
				$I_C = 3A$	$I_B = 0.6A$	
$V_{BE(sat)}^*$	Base – Emitter Saturation Voltage	$I_C = 1A$	$I_B = 0.2A$		0.8	1.0
				$I_C = 2A$	$I_B = 0.4A$	
		$I_C = 3A$	$I_B = 0.6A$		0.95	1.2
DYNAMIC CHARACTERISTICS						
f_t	Transition Frequency	$I_C = 0.2A$	$V_{CE} = 4V$		20	MHz
C_{ob}	Output Capacitance	$V_{CB} = 20V$	$f = 1MHz$		40	pF

* Pulse test $t_p = 300\mu s$, $\delta < 2\%$