



BUT100

HIGH POWER NPN SILICON TRANSISTOR

- SGS-THOMSON PREFERRED SALESTYPE
- NPN TRANSISTOR
- HIGH CURRENT CAPABILITY
- FAST SWITCHING SPEED
- HIGH RUGGEDNESS

APPLICATION

- MOTOR CONTROL
- UNINTERRUPTABLE POWER SUPPLY

DESCRIPTION

The BUT100 is a Multi-epitaxial Planar NPN Transistor in TO-3 package. It is intended for use in high frequency and efficiency converters, switching regulators and motor control.

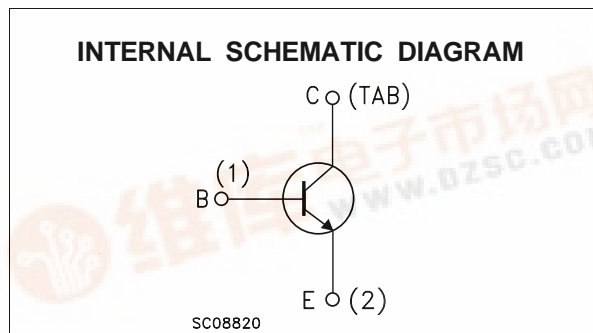
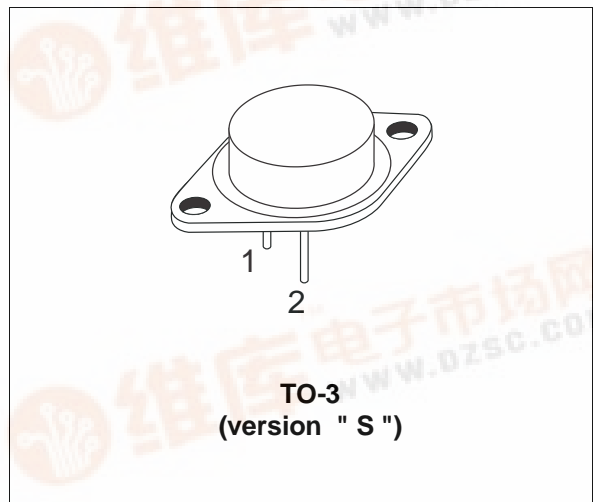

ABSOLUTE MAXIMUM RATINGS

Symbol	Parameter	Value	Unit
V_{CEV}	Collector-Emitter Voltage ($V_{BE} = -1.5V$)	200	V
V_{CEO}	Collector-Emitter Voltage ($I_B = 0$)	125	V
V_{EBO}	Emitter-Base Voltage ($I_C = 0$)	7	V
I_E	Emitter Current	50	A
I_{EM}	Emitter Peak Current	150	A
I_B	Base Current	10	A
I_{BM}	Base Peak Current	30	A
P_{tot}	Total Dissipation at $T_c < 25^\circ C$	300	W
T_{stg}	Storage Temperature	-65 to 200	$^\circ C$
T_j	Max. Operating Junction Temperature	200	$^\circ C$

BUT100

THERMAL DATA

$R_{thj-case}$	Thermal Resistance Junction-case	Max	0.58	°C/W
----------------	----------------------------------	-----	------	------

ELECTRICAL CHARACTERISTICS ($T_{case} = 25\text{ }^{\circ}\text{C}$ unless otherwise specified)

Symbol	Parameter	Test Conditions	Min.	Typ.	Max.	Unit
I_{CER}	Collector Cut-off Current ($R_{BE} = 5\Omega$)	$V_{CE} = V_{CEV}$ $V_{CE} = V_{CEV}$ $T_C = 100^{\circ}\text{C}$			1 5	mA mA
I_{CEV}	Collector Cut-off Current	$V_{CE} = V_{CEV}$ $V_{BE} = -1.5\text{V}$ $V_{CE} = V_{CEV}$ $V_{BE} = -1.5\text{V}$ $T_C = 100^{\circ}\text{C}$			1 4	mA mA
I_{EBO}	Emitter Cut-off Current ($I_C = 0$)	$V_{EB} = 5\text{V}$			1	mA
$V_{CEO(sus)}^*$	Collector-Emitter Sustaining Voltage	$I_C = 0.2\text{A}$ $L = 25\text{mH}$	125			V
V_{EBO}	Emitter-Base Voltage ($I_C = 0$)	$I_E = 50\text{mA}$	7			V
$V_{CE(sat)}^*$	Collector-Emitter Saturation Voltage	$I_C = 50\text{A}$ $I_B = 2.5\text{A}$ $I_C = 100\text{A}$ $I_B = 10\text{A}$ $I_C = 50\text{A}$ $I_B = 2.5\text{A}$ $T_j = 100^{\circ}\text{C}$ $I_C = 100\text{A}$ $I_B = 10\text{A}$ $T_j = 100^{\circ}\text{C}$			0.9 0.9 1.2 1.5	V V V V
$V_{BE(sat)}^*$	Base-Emitter Saturation Voltage	$I_C = 50\text{A}$ $I_B = 2.5\text{A}$ $I_C = 100\text{A}$ $I_B = 10\text{A}$ $I_C = 50\text{A}$ $I_B = 2.5\text{A}$ $T_j = 100^{\circ}\text{C}$ $I_C = 100\text{A}$ $I_B = 10\text{A}$ $T_j = 100^{\circ}\text{C}$			1.4 2 1.4 2.1	V V V V
di_C/dt	Rate of Rise of on-state Collector Current	$V_{CC} = 100\text{V}$ $R_C = 0$ $I_{B1} = 5\text{A}$ $T_p = 3\mu\text{s}$ $T_j = 100^{\circ}\text{C}$	180			A/ μs
t_s t_f t_c	INDUCTIVE LOAD Storage time Fall Time Crossover Time	$V_{CC} = 90\text{V}$ $V_{clamp} = 125\text{V}$ $I_C = 50\text{A}$ $I_{B1} = 2.5\text{A}$ $V_{BB} = -5\text{V}$ $L_C = 80\mu\text{H}$ $R_{B2} = 1\Omega$ $T_j = 100^{\circ}\text{C}$			2 0.2 0.35	μs μs μs
V_{CEW}	Maximum Collector Emitter Voltage without Snubber	$V_{CC} = 90\text{V}$ $I_{Cwoff} = 150\text{A}$ $V_{BB} = -5\text{V}$ $I_{B1} = 10\text{A}$ $L_C = 30\mu\text{H}$ $R_{B2} = 1\Omega$ $T_j = 125^{\circ}\text{C}$	125			V

* Pulsed: Pulse duration = 3 μs , duty cycle = 2%

TO-3 (version S) MECHANICAL DATA

DIM.	mm			inch		
	MIN.	TYP.	MAX.	MIN.	TYP.	MAX.
A	11.00		13.10	0.433		0.516
B	1.47		1.60	0.058		0.063
C	1.50		1.65	0.059		0.065
D	8.32		8.92	0.327		0.351
E	19.00		20.00	0.748		0.787
G	10.70		11.10	0.421		0.437
N	16.50		17.20	0.649		0.677
P	25.00		26.00	0.984		1.023
R	4.00		4.09	0.157		0.161
U	38.50		39.30	1.515		1.547
V	30.00		30.30	1.187		1.193

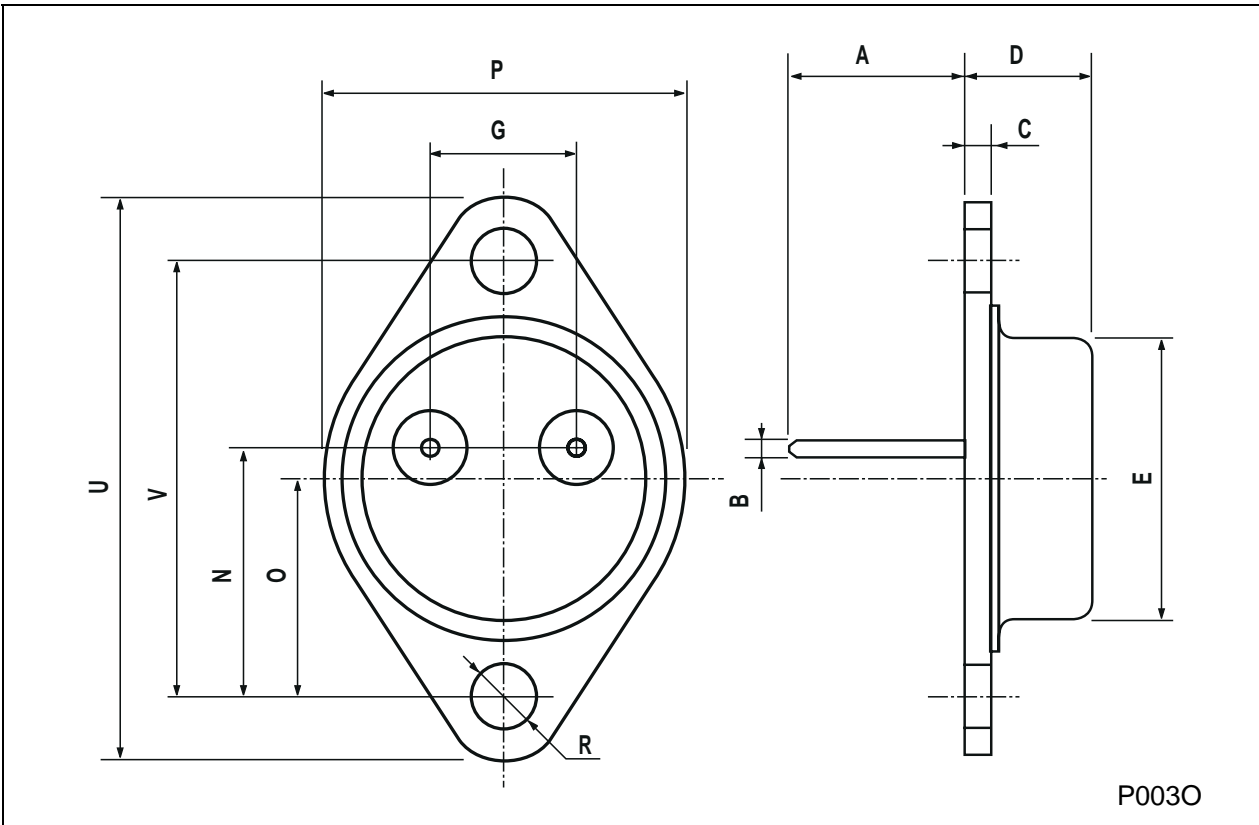

Information furnished is believed to be accurate and reliable. However, SGS-THOMSON Microelectronics assumes no responsibility for the consequences of use of such information nor for any infringement of patents or other rights of third parties which may result from its use. No license is granted by implication or otherwise under any patent or patent rights of SGS-THOMSON Microelectronics. Specifications mentioned in this publication are subject to change without notice. This publication supersedes and replaces all information previously supplied. SGS-THOMSON Microelectronics products are not authorized for use as critical components in life support devices or systems without express written approval of SGS-THOMSON Microelectronics.

© 1997 SGS-THOMSON Microelectronics - Printed in Italy - All Rights Reserved

SGS-THOMSON Microelectronics GROUP OF COMPANIES

Australia - Brazil - Canada - China - France - Germany - Hong Kong - Italy - Japan - Korea - Malaysia - Malta - Morocco - The Netherlands - Singapore - Spain - Sweden - Switzerland - Taiwan - Thailand - United Kingdom - U.S.A

...