

FRED Diode

- Fast recovery epitaxial diode
- Soft recovery characteristics

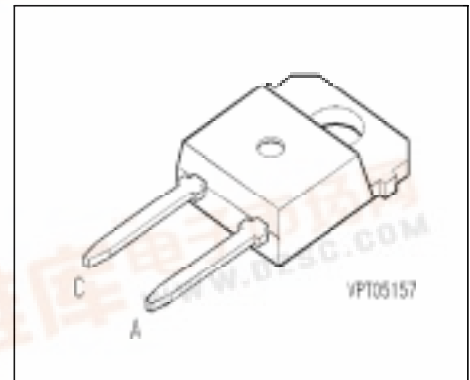

Type	V_{RRM}	I_{FRMS}	t_{rr}	Package	Ordering Code
BYP 301	1200V	20A	80ns	TO-218 AD	C67047-A2251-A2

Maximum Ratings

Parameter	Symbol	Values	Unit
Mean forward current $T_C = 90\text{ }^\circ\text{C}, D = 0.5$	I_{FAV}	12	A
RMS forward current	I_{FRMS}	20	
Surge forward current, sine halfwave, aperiodic $T_j = 100\text{ }^\circ\text{C}, f = 50\text{ Hz}$	I_{FSM}	50	
Repetitive peak forward current $T_j = 100\text{ }^\circ\text{C}, t_p \leq 10\text{ }\mu\text{s}$	I_{FRM}	110	
i^2t value $T_j = 100\text{ }^\circ\text{C}, t_p = 10\text{ ms}$	$\int I^2 dt$	13	A ² s
Repetitive peak reverse voltage	V_{RRM}	1200	V
Surge peak reverse voltage	V_{RSM}	1200	
Power dissipation $T_C = 90\text{ }^\circ\text{C}$	P_{tot}	40	W
Chip or operating temperature	T_j	-40 ... + 150	$^\circ\text{C}$
Storage temperature	T_{stg}	-40 ... + 150	
Thermal resistance, chip case	R_{thJC}	≤ 1.5	K/W
Thermal resistance, chip-ambient	R_{thJA}	≤ 46	
DIN humidity category, DIN 40 040	-	E	-
IEC climatic category, DIN IEC 68-1	-	40 / 150 / 56	

Electrical Characteristics, at $T_j = 25\text{ °C}$, unless otherwise specified

Parameter	Symbol	Values			Unit
		min.	typ.	max.	

Static Characteristics

Forward voltage drop $I_F = 12\text{ A}$, $T_j = 25\text{ °C}$ $I_F = 12\text{ A}$, $T_j = 100\text{ °C}$	V_F	-	2.2 1.8	2.75 -	V
Reverse current $V_R = 1200\text{ V}$, $T_j = 25\text{ °C}$ $V_R = 1200\text{ V}$, $T_j = 100\text{ °C}$ $V_R = 1200\text{ V}$, $T_j = 150\text{ °C}$	I_R	-	0.01 0.05 0.15	0.25 - -	mA

AC Characteristics

Reverse recovery charge $I_F = 12\text{ A}$, $V_{CC} = 500\text{ V}$, $di_F/dt = -1000\text{ A}/\mu\text{s}$ $T_j = 100\text{ °C}$	Q_{rr}	-	2.2	-	μC
Peak reverse recovery current $I_F = 12\text{ A}$, $V_{CC} = 500\text{ V}$, $di_F/dt = -1000\text{ A}/\mu\text{s}$ $T_j = 100\text{ °C}$	I_{RRM}	-	35	-	A
Reverse recovery time $I_F = 12\text{ A}$, $V_{CC} = 500\text{ V}$, $di_F/dt = -1000\text{ A}/\mu\text{s}$ $T_j = 100\text{ °C}$	t_{rr}	-	80	-	ns
Storage time $I_F = 12\text{ A}$, $V_{CC} = 500\text{ V}$, $di_F/dt = -1000\text{ A}/\mu\text{s}$ $T_j = 100\text{ °C}$	t_S	-	45	-	
Softfaktor $I_F = 12\text{ A}$, $V_{CC} = 500\text{ V}$, $di_F/dt = -1000\text{ A}/\mu\text{s}$ $T_j = 100\text{ °C}$	S	-	0.8	-	-

Typ. forward characteristics

$$I_F = f(V_F)$$

parameter: T_j

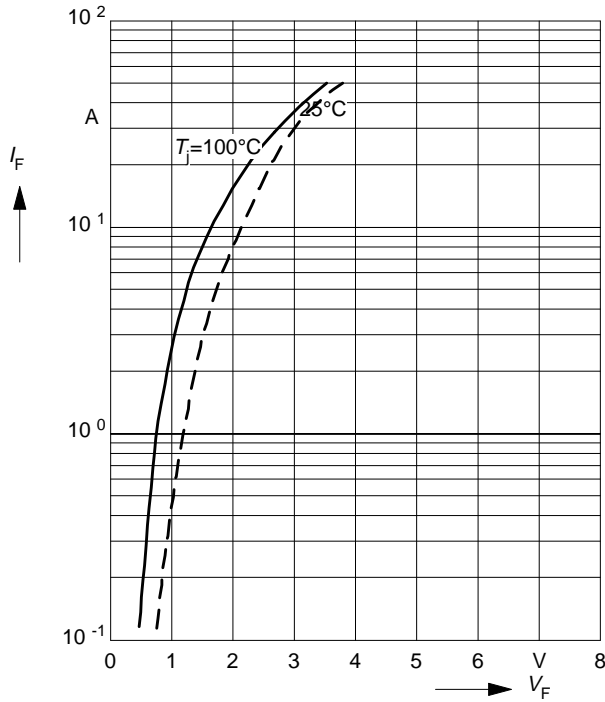

Typ. reverse current

$$I_{RRM} = f(dI_F / dt)$$

parameter: $V_{CC} = 500\text{ V}, I_F = 12\text{ A}, T_j = 100^\circ\text{ C}$

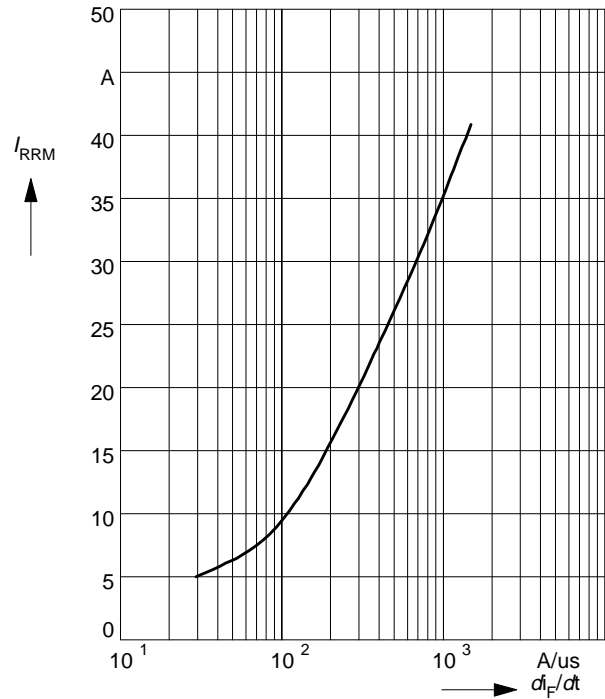

Typ. reverse recovery charge

$$Q_{rr} = f(dI_F / dt)$$

parameter: $V_{CC} = 500\text{ V}, I_F = 12\text{ A}, T_j = 100^\circ\text{ C}$

