

Silicon Press-Fit-Diodes
High-temperature diodes

Silizium-Einpreßdioden
Hochtemperaturdioden

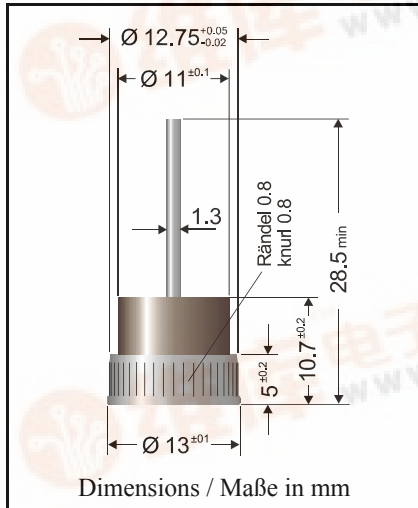

Nominal current – Nennstrom 35 A
 Repetitive peak reverse voltage 50...600 V
 Periodische Spitzensperrspannung
 Metal press-fit case with plastic cover
 Metall-Einpreßgehäuse mit Plastik-Abdeckung
 Weight approx. – Gewicht ca. 10 g
 Casting compound has UL classification 94V-0
 Vergußmasse UL94V-0 klassifiziert
 Standard packaging: bulk
 Standard Lieferform: lose im Karton

Maximum ratings

Grenzwerte

Type / Typ	Repetitive peak reverse voltage	Surge peak reverse voltage
Wire to / Draht an	Periodische Spitzensperrspannung.	Stoßspitzensperrspannung
Anode Cathode	V_{RRM} [V]	V_{RSM} [V]
BYP 35A05 BYP 35K05	50	60
BYP 35A1 BYP 35K1	100	120
BYP 35A2 BYP 35K2	200	240
BYP 35A3 BYP 35K3	300	360
BYP 35A4 BYP 35K4	400	480
BYP 35A6 BYP 35K6	600	700

Max. average forward rectified current, R-load Dauergrenzstrom in Einweschaltung mit R-Last	$T_C = 150^\circ\text{C}$	I_{FAV}	35 A
Repetitive peak forward current Periodischer Spitzenstrom	$f > 15\text{ Hz}$	I_{FRM}	110 A ¹⁾
Peak forward surge current, 50 / 60 Hz half sine-wave Stoßstrom für eine 50 / 60 Hz Sinus-Halbwellen	$T_A = 25^\circ\text{C}$	I_{FSM}	360 / 400 A
Rating for fusing – Grenzlastintegral, $t < 10\text{ ms}$	$T_A = 25^\circ\text{C}$	i^2t	660 A ² s
Operating junction temperature – Sperrschichttemperatur		T_j	- 50...+215 °C
Storage temperature – Lagerungstemperatur		T_s	- 50...+215 °C

Maximum pressure – Maximaler Einpreßdruck 7 kN

¹⁾ Max. case temperature $T_C = 150^\circ\text{C}$ – Max. Gehäusetemperatur $T_C = 150^\circ\text{C}$



Characteristics

Kennwerte

Forward voltage – Durchlaßspannung	$T_j = 25^\circ\text{C}$	$I_F = 35\text{ A}$	V_F	< 1.1 V
Leakage current – Sperrstrom	$T_j = 25^\circ\text{C}$	$V_R = V_{RRM}$	I_R	< 100 μA
Thermal resistance junction to case Wärmewiderstand Sperrschicht – Gehäuse			R_{thC}	< 0.8 K/W

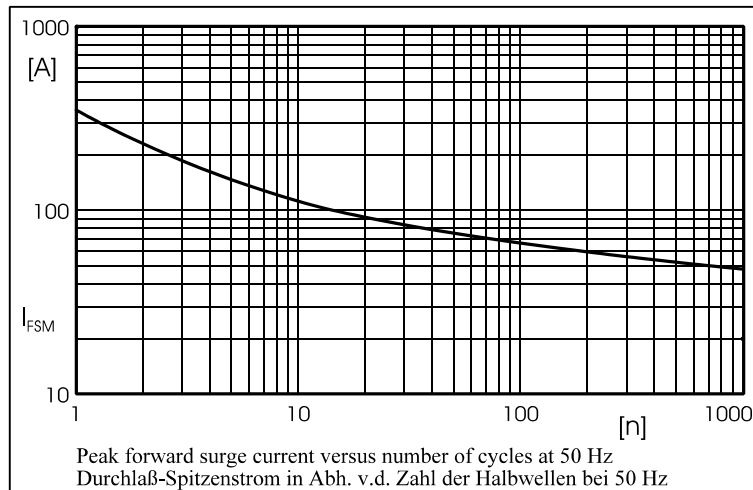
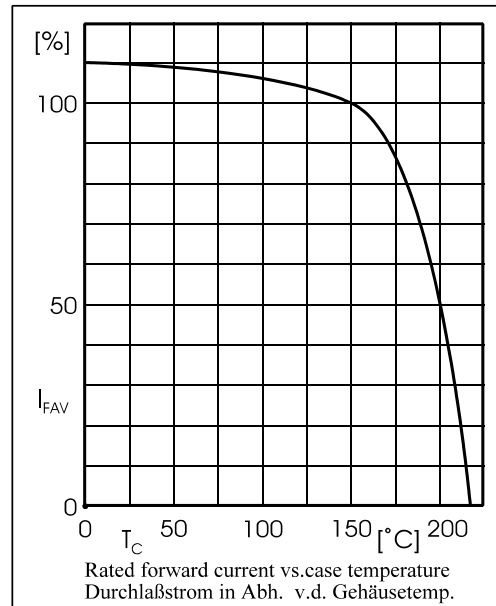
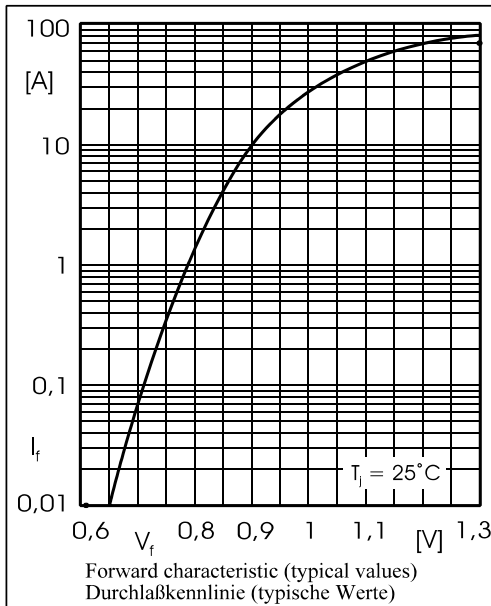

Replacements / Ersatztypen			
New - Neu	Old - Alt	New - Neu	Old - Alt
BYP 35K05	BYP70/35	BYP 35A05	BYP75/35
BYP 35K1	BYP71/35	BYP 35A1	BYP76/35
BYP 35K2	BYP72/35	BYP 35A2	BYP77/35
BYP 35K3	BYP73/35	BYP 35A3	BYP78/35
BYP 35K4	BYP74/35	BYP 35A4	BYP79/35