



BYV27/50 - BYV27/200

2.0A SUPER-FAST GLASS BODY RECTIFIER

Features

- Hermetically Sealed Glass Body Construction
- Controlled Avalanche Characteristics
- Super-Fast Switching for High Efficiency
- High Current Capability and Low Forward Voltage Drop
- Surge Overload Rating to 50A Peak
- Low Reverse Leakage Current

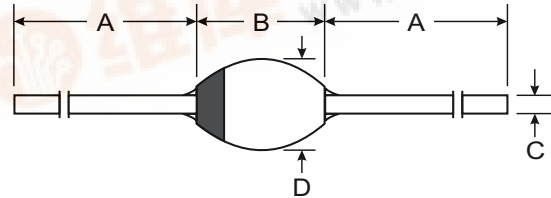

Mechanical Data

- Case: SOD-57, Glass
- Terminals: Plated Leads Solderable per MIL-STD-202, Method 208
- Polarity: Cathode Band
- Weight: 0.50 grams (approx.)
- Mounting Position: Any
- Marking: Type Number

SOD-57		
Dim	Min	Max
A	26.0	—
B	—	4.2
C	—	0.82
D	—	3.6
All Dimensions in mm		

Maximum Ratings and Electrical Characteristics @ T_j = 25°C unless otherwise specified

Characteristic	Symbol	BYV27/50	BYV27/100	BYV27/150	BYV27/200	Unit
Peak Repetitive Reverse Voltage Working Peak Reverse Voltage DC Blocking Voltage	V_{RRM} V_{RWM} V_R	50	100	150	200	V
RMS Reverse Voltage	$V_{R(RMS)}$	35	70	100	140	V
Non-Repetitive Peak Reverse Voltage	V_{RSM}	55	110	165	220	V
Average Rectified Output Current (Note 1)	I_O	2.0				A
Non-Repetitive Peak Forward Surge Current 8.3ms single half sine-wave superimposed on rated load (JEDEC Method)	I_{FSM}	50				A
Repetitive Forward Surge Current	I_{FRM}	15				A
Forward Voltage @ $I_F = 5.0A$	V_{FM}	1.1				V
Peak Reverse Current @ $T_j = 25^\circ C$ at Rated DC Blocking Voltage @ $T_j = 165^\circ C$	I_{RM}	1.0 150				μA
Non-Repetitive Reverse Avalanche Energy $I_R = 0.6A$ Inductive Load @ $T_j = 175^\circ C$	E_{RSM}	20				mJ
Reverse Recovery Time (Note 2)	t_{rr}	25				ns
Typical Thermal Resistance Junction to Ambient (Note 1)	$R_{\theta JA}$	45				K/W
Operating and Storage Temperature Range	T_j, T_{STG}	-65 to +175				$^\circ C$

- Notes: 1. Leads maintained at ambient temperature at a distance of 10mm from the case.
2. Measured with $I_F = 0.5A$, $I_R = 1.0A$, $I_{rr} = 0.25A$. See Figure 4.



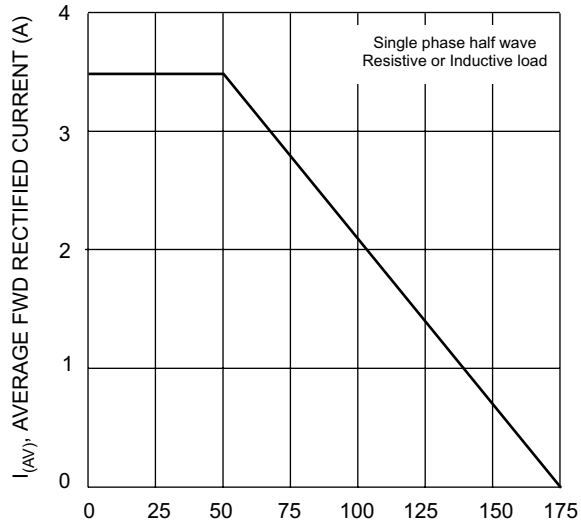

Fig. 1 Forward Current Derating Curve

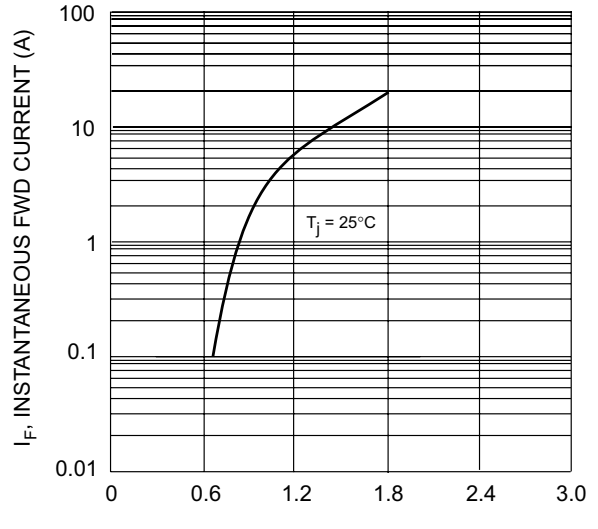

Fig. 2 Typical Forward Characteristics

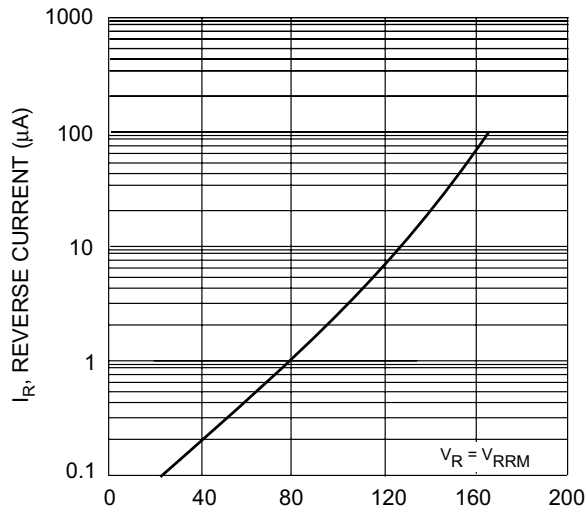
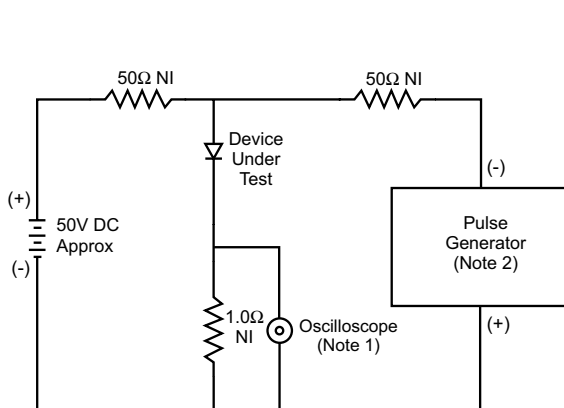
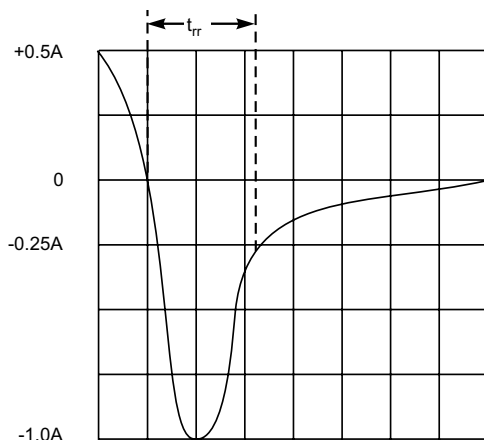

Fig. 3 Typical Reverse Characteristics



- Notes:
1. Rise Time = 7.0ns max. Input impedance = 1.0MΩ, 22pF.
 2. Rise Time = 10ns max. Input impedance = 50Ω.



Set time base for 50/100 ns/cm

Fig. 4 Reverse Recovery Time Characteristic and Test Circuit