



MOS INTEGRATED CIRCUIT  
**μPD72873**

**IEEE1394 OHCI 1.1 COMPLIANT 2PORT PHY-LINK 1-CHIP HOST CONTROLLER**

The μPD72873 is the LSI that integrated OHCI-Link and PHY function into a single chip. The μPD72873 complies with the 1394 OHCI Specification 1.1 and the IEEE Std 1394a-2000 specifications, and works up to 400 Mbps. It makes design so compact for PC and PC card application.

**FEATURES**

- Compliant with Link Layer Services as defined in 1394 Open Host Controller Interface specification release 1.1
- Compliant with Physical Layer Services as defined in IEEE Std 1394a-2000
- Provides two cable ports at 100/200/400 Mbps
- Super Low power consumption for Physical Layer
- Compliant with protocol enhancement as defined in IEEE Std1394a-2000
- Modular 32-bit host interface compliant to PCI Specification release 2.2
- Supports PCI-Bus Power Management Interface Specification release 1.1
- Modular 32-bit host interface compliant to Card Bus Specification
- Cycle Master and Isochronous Resource Manager capable
- Built-in FIFOs for isochronous transmit (2048 bytes), asynchronous transmit (2048 bytes), and receive (3072 bytes)
- Supports D0, D1, D2, D3hot
- Supports wake up function from D3cold
- 32-bit CRC generation and checking for receive/transmit packets
- 4 isochronous transmit DMAs and 4 isochronous receive DMAs supported
- 32-bit DMA channels for physical memory read/write
- Clock generation by 24.576 MHz X'tal
- 2-wire Serial EEPROM™ interface supported
- Separate power supply Link and PHY
- Programmable latency timer from serial EEPROM in Cardbus mode (CARD\_ON = 1)

**ORDERING INFORMATION**

Part number	Package
★ μPD72873GC-YEB	120-pin plastic TQFP (Fine pitch) (14 x 14)

The information in this document is subject to change without notice. Before using this document, please confirm that this is the latest version.  
Not all devices/types available in every country. Please check with local NEC representative for availability and additional information.

Firewarden™ ROADMAP

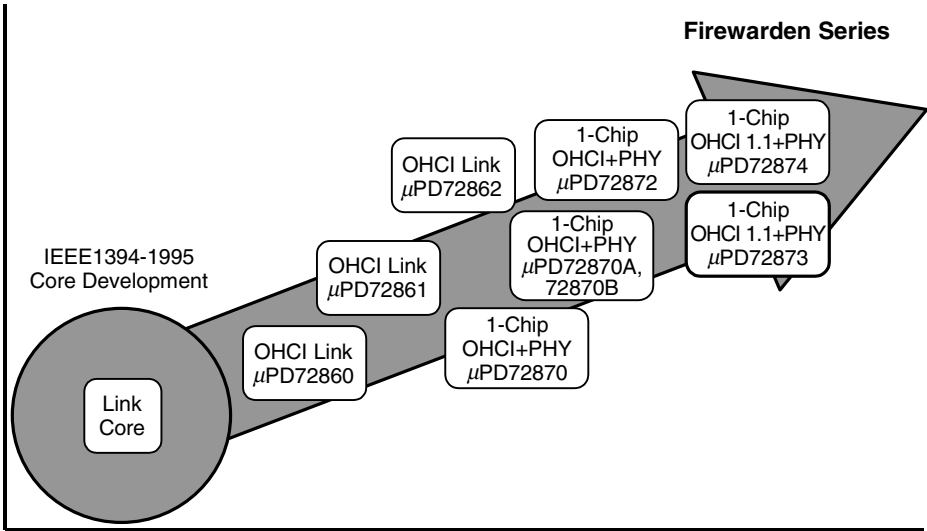

BLOCK DIAGRAMS

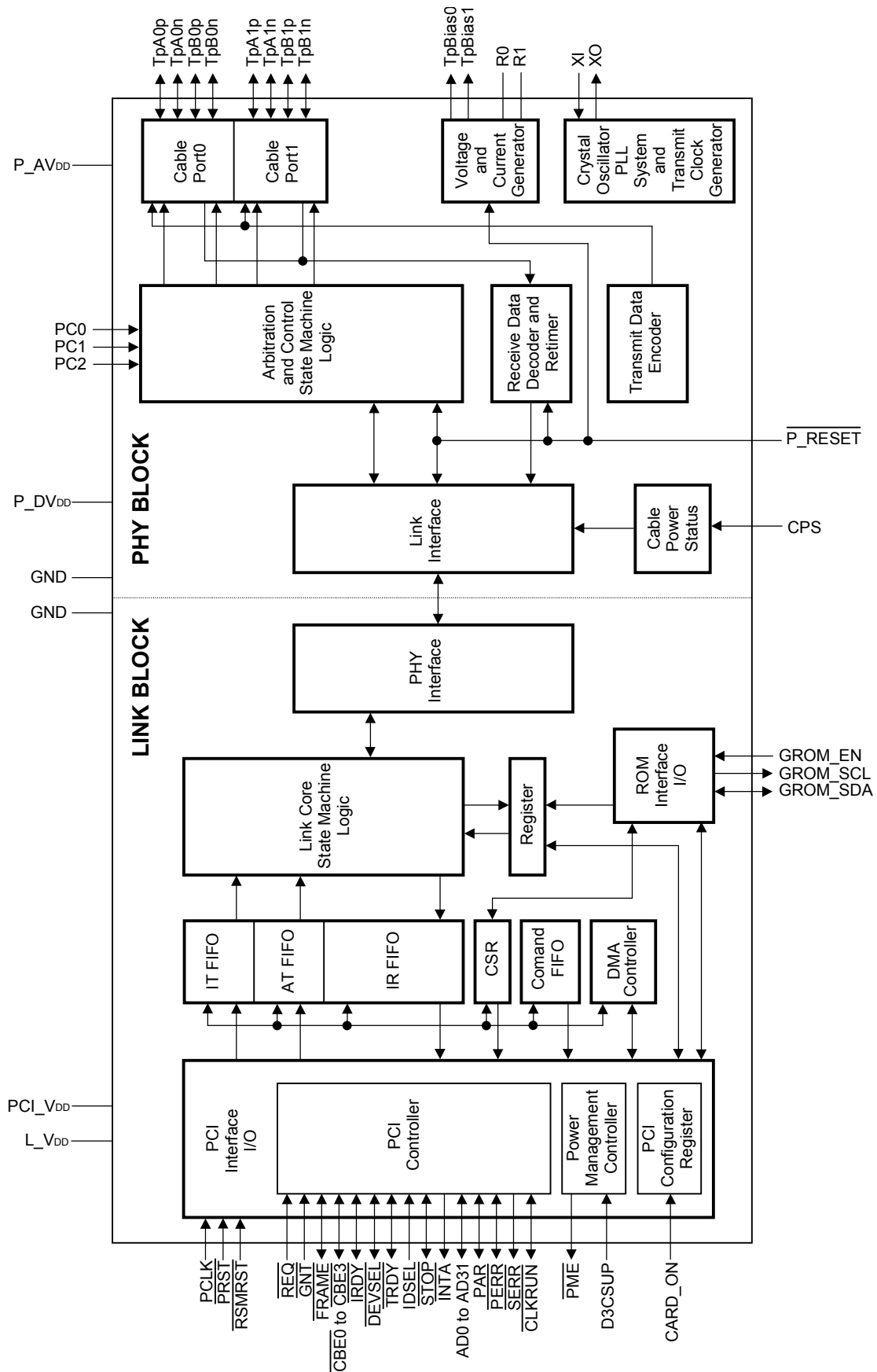

★ PIN CONFIGURATION (TOP VIEW)

• 120-pin plastic TQFP (Fine pitch) (14 x 14)

μPD72873GC-YEB

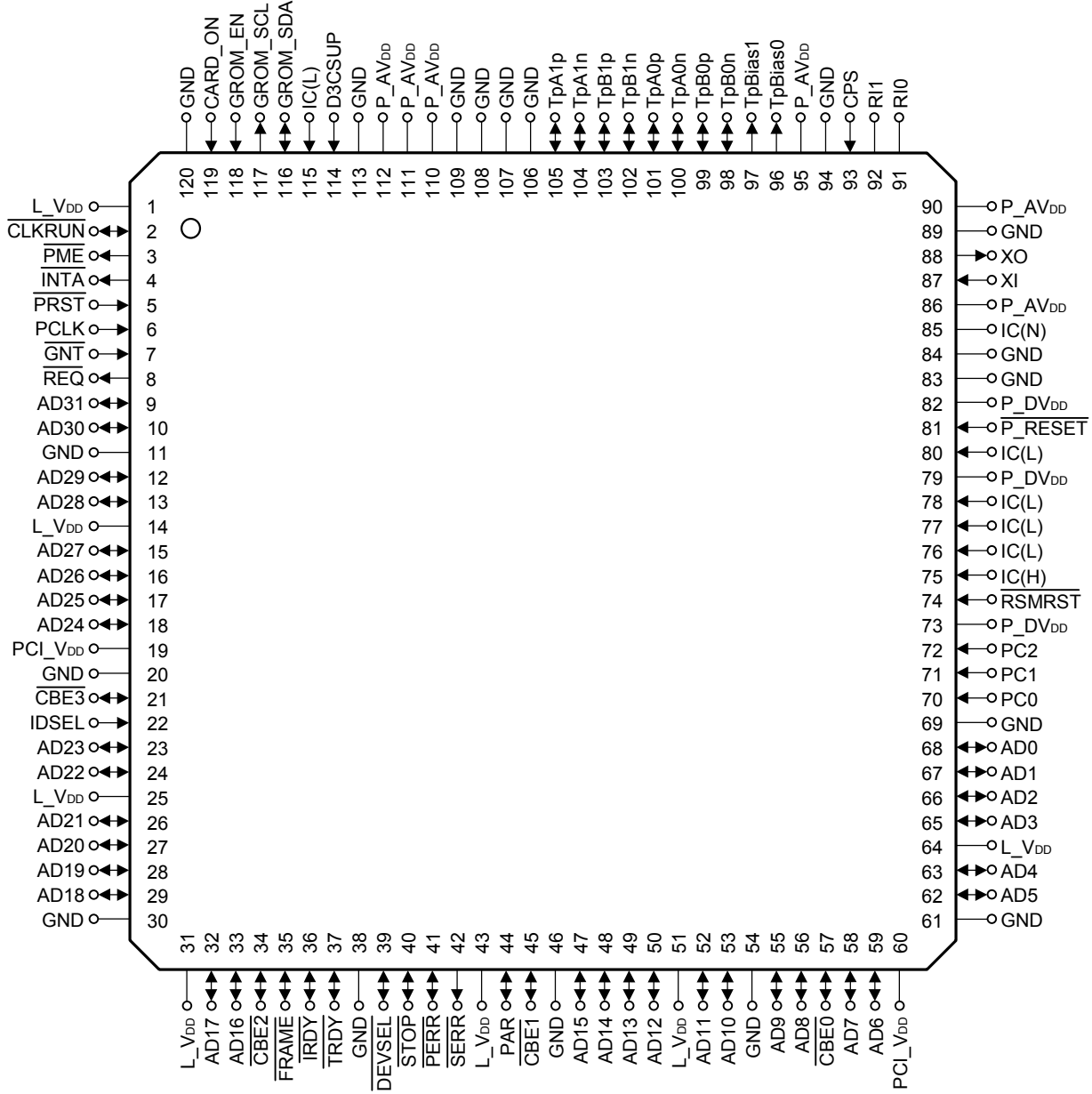

**PIN NAME**

AD0 to AD31	: PCI Multiplexed Address and Data	$\overline{\text{PERR}}$	: Parity Error
CARD_ON	: PCI/Card Select	$\overline{\text{PME}}$	: PME Output
$\overline{\text{CBE0}}$ to	: Command/Byte Enables	$\overline{\text{PRST}}$	: Reset
$\overline{\text{CBE3}}$		P_AVDD	: PHY Analog VDD
$\overline{\text{CLKRUN}}$	: PCICLK Running	P_DVDD	: PHY Digital VDD
CPS	: Cable Power Status Input	$\overline{\text{P\_RESET}}$	: PHY Power on Reset Input
D3CSUP	: D3cold Support	$\overline{\text{REQ}}$	: Bus_master Request
$\overline{\text{DEVSEL}}$	: Device Select	RI0	: Resistor0 for Reference Current Setting
$\overline{\text{FRAME}}$	: Cycle Frame	RI1	: Resistor1 for Reference Current Setting
GND	: GND	$\overline{\text{RSMRST}}$	: Resume Reset
$\overline{\text{GNT}}$	: Bus_master Grant	$\overline{\text{SERR}}$	: System Error
GROM_EN	: Serial EEPROM Enable	$\overline{\text{STOP}}$	: PCI Stop
GROM_SCL	: Serial EEPROM Clock Output	TpA0n	: Port-1 Twisted Pair A Negative Input/Output
GROM_SDA	: Serial EEPROM Data Input / Output	TpA0p	: Port-1 Twisted Pair A Positive Input/Output
IC(H)	: Internally Connected (High Clamped)	TpA1n	: Port-2 Twisted Pair A Negative Input/Output
IC(L)	: Internally Connected (Low Clamped)	TpA1p	: Port-2 Twisted Pair A Positive Input/Output
IC(N)	: Internally Connected (Open)	TpB0n	: Port-1 Twisted Pair B Negative Input/Output
IDSEL	: ID Select	TpB0p	: Port-1 Twisted Pair B Positive Input/Output
$\overline{\text{INTA}}$	: Interrupt	TpB1n	: Port-2 Twisted Pair B Negative Input/Output
$\overline{\text{IRDY}}$	: Initiator Ready	TpB1p	: Port-2 Twisted Pair B Positive Input/Output
L_VDD	: VDD for Link Digital Core and Link I/Os	TpBias0	: Port-1 Twisted Pair Bias Voltage Output
PAR	: Parity	TpBias1	: Port-2 Twisted Pair Bias Voltage Output
PC0 to PC2	: Power Class Input	$\overline{\text{TRDY}}$	: Target Ready
PCI_VDD	: VDD for PCI I/Os	XI	: X'tal XI
PCLK	: PCI Clock	XO	: X'tal XO

CONTENTS

- 1. PIN FUNCTIONS..... 8**
  - 1.1 PCI/Cardbus Interface Signals: (52 pins) ..... 8**
  - 1.2 PHY Signals: (15 pins) ..... 10**
  - 1.3 PHY Control Signals: (4 pins)..... 10**
  - 1.4 PCI/Cardbus Select Signal: (1 pin)..... 10**
  - 1.5 Serial ROM Interface Signals: (3 pins)..... 11**
  - 1.6 D3cold Wake Up Function Signals: (2 pins) ..... 11**
  - 1.7 IC: (7 pins)..... 11**
  - 1.8 V<sub>DD</sub>..... 12**
  - 1.9 GND..... 12**
  
- 2. PHY REGISTERS..... 13**
  - 2.1 Complete Structure for PHY Registers..... 13**
  - 2.2 Port Status Page (Page 000)..... 16**
  - 2.3 Vendor ID Page (Page 001)..... 17**
  - 2.4 Vendor Dependent Page (Page 111 : Port\_select 0001) ..... 17**
  
- 3. CONFIGURATION REGISTERS ..... 18**
  - 3.1 PCI Bus Mode Configuration Register (CARD\_ON = Low)..... 18**
    - 3.1.1 Offset\_00 Vendor ID Register ..... 19
    - 3.1.2 Offset\_02 Device ID Register..... 19
    - 3.1.3 Offset\_04 Command Register..... 19
    - 3.1.4 Offset\_06 Status Register..... 20
    - 3.1.5 Offset\_08 Revision ID Register..... 21
    - 3.1.6 Offset\_09 Class Code Register..... 21
    - 3.1.7 Offset\_0C Cache Line Size Register..... 21
    - 3.1.8 Offset\_0D Latency Timer Register..... 21
    - 3.1.9 Offset\_0E Header Type Register ..... 21
    - 3.1.10 Offset\_0F BIST Register ..... 21
    - 3.1.11 Offset\_10 Base Address 0 Register..... 22
    - 3.1.12 Offset\_2C Subsystem Vendor ID Register..... 22
    - 3.1.13 Offset\_2E Subsystem ID Register..... 22
    - 3.1.14 Offset\_34 Cap\_Ptr Register ..... 22
    - 3.1.15 Offset\_3C Interrupt Line Register..... 22
    - 3.1.16 Offset\_3D Interrupt Pin Register ..... 23
    - 3.1.17 Offset\_3E Min\_Gnt Register ..... 23
    - 3.1.18 Offset\_3F Max\_Lat Register ..... 23
    - 3.1.19 Offset\_40 PCI\_OHCI\_Control Register..... 23
    - 3.1.20 Offset\_60 Cap\_ID & Next\_Item\_Ptr Register..... 23
    - 3.1.21 Offset\_62 Power Management Capabilities Register..... 24
    - 3.1.22 Offset\_64 Power Management Control/Status Register..... 25
  - 3.2 CardBus Mode Configuration Register (CARD\_ON = High)..... 26**
    - 3.2.1 Offset\_14/18 Base Address 1/2 Register (Cardbus Status Registers)..... 27
    - 3.2.2 Offset\_28 Cardbus CIS Pointer..... 28
    - 3.2.3 Offset\_80 CIS Area ..... 28

- 4. PHY FUNCTION..... 29**
  - 4.1 Cable Interface..... 29**
    - 4.1.1 Connections ..... 29
    - 4.1.2 Cable Interface Circuit..... 30
    - 4.1.3 CPS ..... 30
    - 4.1.4 Unused Ports..... 30
  - 4.2 PLL and Crystal Oscillation Circuit ..... 30**
    - 4.2.1 Crystal Oscillation Circuit ..... 30
    - 4.2.2 PLL ..... 30
  - 4.3 PC0 to PC2 ..... 30**
  - 4.4 P\_RESET ..... 30**
  - 4.5 RI0, RI1 ..... 30**
  
- 5. ELECTRICAL SPECIFICATIONS..... 31**
  
- 6. PACKAGE DRAWING ..... 34**
  
- 7. RECOMMENDED SOLDERING CONDITIONS..... 35**

1. PIN FUNCTIONS

1.1 PCI/Cardbus Interface Signals: (52 pins)

(1/2)

Name	I/O	Pin No.	I <sub>OL</sub>	Volts(V)	Function	Block *
PAR	I/O	44	PCI/Cardbus	5/3.3	<b>Parity</b> is even parity across AD0 to AD31 and $\overline{CBE0}$ to $\overline{CBE3}$ . It is an input when AD0 to AD31 is an input; it is an output when AD0 to AD31 is an output.	Link
AD0 to AD31	I/O	9, 10, 12, 13, 15 to 18, 23, 24, 26 to 29. 32. 33. 47to 50, 52, 53, 55, 56, 58, 59, 62, 63, 65 to 68	PCI/Cardbus	5/3.3	<b>PCI Multiplexed Address and Data</b>	Link
$\overline{CBE0}$ to $\overline{CBE3}$	I/O	21, 34, 45, 57	-	5/3.3	<b>Command/Byte Enables</b> are multiplexed bus commands & byte enables.	Link
FRAME	I/O	35	PCI/Cardbus	5/3.3	<b>Frame</b> is asserted by the initiator to indicate the cycle beginning and is kept asserted during the burst cycle. If Cardbus mode (CARD_ON = 1), this pin should be pulled up to V <sub>DD</sub> .	Link
$\overline{TRDY}$	I/O	37	PCI/Cardbus	5/3.3	<b>Target Ready</b> indicates that the current data phase of the transaction is ready to be completed.	Link
$\overline{IRDY}$	I/O	36	PCI/Cardbus	5/3.3	<b>Initiator Ready</b> indicates that the current bus master is ready to complete the current data phase. During a write, its assertion indicates that the initiator is driving valid data onto the data bus. During a read, its assertion indicates that the initiator is ready to accept data from the currently-addressed target.	Link
$\overline{REQ}$	O	8	PCI/Cardbus	5/3.3	<b>Bus_master Request</b> indicates to the bus arbiter that this device wants to become a bus master.	Link
$\overline{GNT}$	I	7	-	5/3.3	<b>Bus_master Grant</b> indicates to this device that access to the bus has been granted.	Link
IDSEL	I	22	-	5/3.3	<b>Initialization Device Select</b> is used as chip select for configuration read/write transaction during the phase of device initialization. If Cardbus mode (CARD_ON = 1), this pin should be pulled up to V <sub>DD</sub> .	Link
$\overline{DEVSEL}$	I/O	39	PCI/Cardbus	5/3.3	<b>Device Select</b> when actively driven, indicates that the driving device has decoded its address as the target of the current access.	Link
$\overline{STOP}$	I/O	40	PCI/Cardbus	5/3.3	<b>PCI Stop</b> when actively driven, indicates that the target is requesting the current bus master to stop the transaction.	Link
$\overline{PME}$	O	3	PCI/Cardbus	5/3.3	<b>PME Output</b> for power management event.	Link

**Remark** \*: If the Link pin is pulled up, it should be connected to L\_V<sub>DD</sub>.

(2/2)

Name	I/O	Pin No.	I <sub>OL</sub>	Volts(V)	Function	Block *
CLKRUN	I/O	2	PCI/Cardbus	5/3.3	<b>PCICLK Running</b> as input, to determine the status of PCLK; as output, to request starting or speeding up clock.	Link
INTA	O	4	PCI/Cardbus	5/3.3	<b>Interrupt</b> the PCI interrupt request A.	Link
PERR	I/O	41	PCI/Cardbus	5/3.3	<b>Parity Error</b> is used for reporting data parity errors during all PCI transactions, except a special cycle. It is an output when AD0 to AD31 and PAR are both inputs. It is an input when AD0 to AD31 and PAR are both outputs.	Link
SERR	O	42	PCI/Cardbus	5/3.3	<b>System Error</b> is used for reporting address parity errors, data parity errors during the special cycle, or any other system error where the effect can be catastrophic. When reporting address parity errors, it is an output.	Link
PRST	I	5	-	5/3.3	<b>Reset</b> PCI reset	Link
PCLK	I	6	-	5/3.3	<b>PCI Clock</b> 33 MHz system bus clock.	Link

**Remark** \*: If the Link pin is pulled up, it should be connected to L\_VDD.

**1.2 PHY Signals: (15 pins)**

Name	I/O	Pin No.	IoL	Volts(V)	Function	Block *
TpA0p	I/O	101	-	-	Port-1 Twisted Pair A Positive Input/Output <sup>Note 1</sup>	PHY Analog
TpA0n	I/O	100	-	-	Port-1 Twisted Pair A Negative Input/Output <sup>Note 1</sup>	PHY Analog
TpB0p	I/O	99	-	-	Port-1 Twisted Pair B Positive Input/Output <sup>Note 1</sup>	PHY Analog
TpB0n	I/O	98	-	-	Port-1 Twisted Pair B Negative Input/Output <sup>Note 1</sup>	PHY Analog
TpA1p	I/O	105	-	-	Port-2 Twisted Pair A Positive Input/Output <sup>Note 1</sup>	PHY Analog
TpA1n	I/O	104	-	-	Port-2 Twisted Pair A Negative Input/Output <sup>Note 1</sup>	PHY Analog
TpB1p	I/O	103	-	-	Port-2 Twisted Pair B Positive Input/Output <sup>Note 1</sup>	PHY Analog
TpB1n	I/O	102	-	-	Port-2 Twisted Pair B Negative Input/Output <sup>Note 1</sup>	PHY Analog
CPS	I	93	-	-	Cable Power Status Input <sup>Note2</sup>	PHY Digital
TpBias0	O	96	-	-	Port-1 Twisted Pair Bias Voltage Output <sup>Note 1</sup>	PHY Analog
TpBias1	O	97	-	-	Port-2 Twisted Pair Bias Voltage Output <sup>Note 1</sup>	PHY Analog
RI0	-	91	-	-	Resistor0 for Reference Current Setting <sup>Note 3</sup>	PHY Analog
RI1	-	92	-	-	Resistor1 for Reference Current Setting <sup>Note 3</sup>	PHY Analog
XI	I	87	-	-	X'tal XI	PHY Analog
XO	O	88	-	-	X'tal XO	PHY Analog

**Notes 1.** If unused port, please refer to **4.1.4 Unused Ports**.

**2.** Please refer to **4.1.3 CPS**.

**3.** Please refer to **4.5 RI0, RI1**.

**Remark \*** If the PHY Digital pin is pulled up, it should be connected to P\_DVDD.

If the PHY Analog pin is pulled up, it should be connected to P\_AVDD.

**1.3 PHY Control Signals: (4 pins)**

Name	I/O	Pin No.	IoL	Volts(V)	Function	Block *
PC0 to PC2	I	70 to 72	-	3.3	Power Class Input <sup>Note 1</sup>	PHY Digital
$\overline{\text{P\_RESET}}$	I	81	-	-	PHY Power on Reset Input <sup>Note 2</sup>	PHY Digital

**Notes 1.** Please refer to **4.3 PC0 to PC2**.

**2.** Please refer to **4.4  $\overline{\text{P\_RESET}}$** .

**Remark \*** If the PHY Digital pin is pulled up, it should be connected to P\_DVDD.

**1.4 PCI/Cardbus Select Signal: (1 pin)**

Name	I/O	Pin No.	IoL	Volts(V)	Function	Block *
CARD_ON	I	119	-	3.3	PCI/CardBus Select 1:Cardbus mode 0:PCI bus mode	Link

**Remark \*** If the Link pin is pulled up, it should be connected to L\_VDD.

**1.5 Serial ROM Interface Signals: (3 pins)**

Name	I/O	Pin No.	I <sub>OL</sub>	Volts(V)	Function	Block *
GROM_SDA	I/O	116	6 mA	3.3	<b>Serial EEPROM Data Input / Output</b>	Link
GROM_SCL	O	117	6 mA	3.3	<b>Serial EEPROM Clock Output</b>	Link
GROM_EN	I	118	-	3.3	<b>Serial EEPROM Enable</b> 1: GUID Load enable 0: GUID Load disable	Link

**Remark** \*: If the Link pin is pulled up, it should be connected to L\_V<sub>DD</sub>.

★ **1.6 D3cold Wake Up Function Signals: (2 pins)**

Name	I/O	Pin No.	I <sub>OL</sub>	Volts(V)	Function	Block *
D3CSUP	I	114	-	5/3.3	<b>D3cold Support</b> 1: D3cold wake up enable 0: D3cold wake up disable	Link
$\overline{\text{RSMRST}}$	I	74	-	5/3.3	<b>Resume Reset</b> D3cold support (114 pin) = '1' As this mode supports D3cold wake up, $\overline{\text{RSMRST}}$ must connect system $\overline{\text{RSMRST}}$ signal.  D3cold support (114 pin) = '0' As this mode is the μPD72872 compatible, $\overline{\text{RSMRST}}$ clamp to '1'.	Link

**Remark** \*: If the Link pin is pulled up, it should be connected to L\_V<sub>DD</sub>.

**1.7 IC: (7 pins)**

Name	I/O	Pin No.	I <sub>OL</sub>	Volts(V)	Function	Block *
IC(H)	I	75	-	-	<b>Internally Connected</b> (High clamped)	Link
IC(L)	I	76 to 78, 80, 115	-	-	<b>Internally Connected</b> (Low clamped)	-
IC(N)	-	85	-	-	<b>Internally Connected</b> (Open)	-

**Remark** \*: If the Link pin is pulled up, it should be connected to L\_V<sub>DD</sub>.

1.8 V<sub>DD</sub>

Name	I/O	Pin No.	I <sub>OL</sub>	Volts(V)	Function	Block *
PCI_V <sub>DD</sub>	-	19, 60	-	5/3.3	<b>V<sub>DD</sub> for PCI I/Os</b>	Link
L_V <sub>DD</sub>	-	1, 14, 25, 31, 43, 51, 64	-	3.3	<b>V<sub>DD</sub> for Link digital Core and Link I/Os</b> To use D3cold wake up function, L_V <sub>DD</sub> must switch V <sub>DD</sub> to Vaux when the system suspend.	Link
P_DV <sub>DD</sub>	-	73, 79, 82	-	3.3	<b>PHY digital V<sub>DD</sub></b>	PHY Digital
P_AV <sub>DD</sub>	-	86, 90, 95, 110 to 112	-	3.3	<b>PHY Analog V<sub>DD</sub></b>	PHY Analog

**Remark** \*: If the Link pin is pulled up, it should be connected to L\_V<sub>DD</sub>.  
 If the PHY Digital pin is pulled up, it should be connected to P\_DV<sub>DD</sub>.  
 If the PHY Analog pin is pulled up, it should be connected to P\_AV<sub>DD</sub>.

1.9 GND

Name	I/O	Pin No.	I <sub>OL</sub>	Volts(V)	Function	Block
GND	-	11, 20, 30, 38, 46, 54, 61, 69, 83, 84, 89, 94, 106 to 109, 113, 120	-	-	<b>GND</b>	-

2. PHY REGISTERS

2.1 Complete Structure for PHY Registers

Figure 2-1. Complete Structure of PHY Registers

	0	1	2	3	4	5	6	7
0000	Physical_ID						R	PS
0001	RHB	IBR	Gap_count					
0010	Extended (7)			Reserved	Total_ports			
0011	Max_speed			Reserved	Delay			
0100	Link_active	Contender	Jitter			Pwr_class		
0101	Watchdog	ISBR	Loop	Pwr_fail	Timeout	Port_event	Enab_accel	Enab_multi
0110	Reserved							
0111	Page_select			Reserved	Port_select			
1000	Register0 (page_select)							
1001	Register1 (page_select)							
1010	Register2 (page_select)							
1011	Register3 (page_select)							
1100	Register4 (page_select)							
1101	Register5 (page_select)							
1110	Register6 (page_select)							
1111	Register7 (page_select)							

Table 2-1. Bit Field Description (1/3)

Field	Size	R/W	Reset value	Description
Physical_ID	6	R	000000	Physical_ID value selected from Self_ID period.
R	1	R	0	If this bit is 1, the node is root. 1: Root 0: Not root
PS	1	R		Cable power status. 1: Cable power on 0: Cable power off
RHB	1	R/W	0	Root Hold -off bit. If 1, becomes root at the bus reset.
IBR	1	R/W	0	Initiate bus reset. Setting to 1 begins a long bus reset. Long bus reset signal duration: 166 μsec. Returns to 0 at the beginning of bus reset.
Gap_count	6	R/W	111111	Gap count value. It is updated by the changes of transmitting and receiving the PHY configuration packet Tx/Rx. The value is maintained after first bus reset. After the second bus reset it returns to reset value.
Extended	3	R	111	Shows the extended register map.

Table 2-1. Bit Field Description (2/3)

Field	Size	R/W	Reset value	Description
Total_ports	4	R	0011	Supported port number. 0010: 2 ports
Max_speed	3	R	010	Indicate the maximum speed that this node supports. 010: 98.304, 196.608 and 393.216 Mbps
Delay	4	R	0000	Indicate worst case repeating delay time. $144 + (\text{Delay} \times 20) = 144 \text{ nsec}$
Link_active	1	R/W	1	Link active. 1: Enable 0: Disable  The logical AND status of this bit and LPS. State will be referred to "L bit" of Self-ID Packet#0. The LPS is a PHY/Link interface signal and is defined in P1394a-2000. It is an internal signal in the μPD72873.
Contender	1	R/W	0	Contender. "1" indicate this node support bus manager function. This bit will be referred to "C bit" of Self-ID Packet#0.
Jitter	3	R	010	The difference of repeating time (Max.-Min.). $(2+1) \times 20=60 \text{ nsec}$
Pwr_class	3	R/W	See Description	Power class. Please refer to IEEE1394a-2000 [4.3.4.1]. This bit will be referred to Pwr field of Self-ID Packet#0.
Watchdog	1	R/W	0	Watchdog Enable. This bit serves two purposes. When set to 1, if any one port does resume, the Port_event bit becomes 1. To determine whether or not an interrupt condition shall be indicated to the link. On condition of LPS = 0 and Watchdog = 0, LKON as interrupt of Loop, Pwr_fail, Timeout is not output.
ISBR	1	R/W	0	Initiate short (arbitrated) bus reset. Setting to 1 acquires the bus and begins short bus reset. Short bus reset signal output : 1.3 μsec Returns to 0 at the beginning of the bus reset.
Loop	1	R/W	0	Loop detection output. 1: Detection Writing 1 to this bit clears it to 0. Writing 0 has no effect.
Pwr_fail	1	R/W	1	Power cable disconnect detect. It becomes 1 when there is a change from 1 to 0 in the CPS bit. Writing 1 to this bit clears it to 0. Writing 0 has no effect.

Table 2-1. Bit Field Description (3/3)

Field	Size	R/W	Reset value	Description
Timeout	1	R/W	0	Arbitration state machine time-out. Writing 1 to this bit clears it to 0. Writing 0 has no effect.
Port_event	1	R/W	0	Set to 1 when the Int_enable bit in the register map of each port is 1 and there is a change in the ports connected, Bias, Disabled and Fault bits. Set to 1 when the Watchdog bit is 1 and any one port does resume. Writing 1 to this bit clears it to 0. Writing 0 has no effect.
Enab_accel	1	R/W	0	Enables arbitration acceleration. Ack-acceleration and Fly-by arbitration are enabled. 1: Enabled 0: Disabled If this bit changes while the bus request is pending, the operation is not guaranteed.
Enab_multi	1	R/W	0	Enable multi-speed packet concatenation. Setting this bit to 1 follows multi-speed transmission. When this bit is set to 0, the packet will be transmitted with the same speed as the first packet.
Page_select	3	R/W	000	Select page address between 1000 to 1111. 000: Port Status Page 001: Vendor ID Page 111: Vendor Dependent Page Others: Unused
Port_select	4	R/W	0000	Port Selection. Selecting 000 (Port Status Page) with the Page_select selects the port. Selecting 111 (Vendor Dependent Page) with the Page_select have to select the Port 1. 0000: Port 0 0001: Port 1 Others: Unused
Reserved	-	R	000...	Reserved. Read as 0.

2.2 Port Status Page (Page 000)

Figure 2-2. Port Status Page

	0	1	2	3	4	5	6	7
1000	AStat		BStat		Child	Connected	Bias	Disabled
1001	Negotiated_speed			Int_enable	Fault	Reserved		
1010	Reserved							
1011	Reserved							
1100	Reserved							
1101	Reserved							
1110	Reserved							
1111	Reserved							

Table 2-2. Bit Field Description

Field	Size	R/W	Reset value	Description
AStat	2	R	XX	A port status value. 00: invalid, 10: "0" 01: "1", 11: "Z"
BStat	2	R	XX	B port status value. 00: invalid, 10: "0" 01: "1", 11: "Z"
Child	1	R		Child node status value. 1: Connected to child node 0: Connected to parent node
Connected	1	R	0	Connection status value. 1: Connected 0: Disconnected
Bias	1	R		Bias voltage status value. 1: Bias voltage 0: No bias voltage
Disabled	1	R/W	See Description	The reset value is set to 0: Enabled.
Negotiated_Speed	3	R		Shows the maximum data transfer rate of the node connected to this port. 000: 100 Mbps 001: 200 Mbps 010: 400 Mbps
Int_enable	1	R/W	0	When set to 1, the Port_event is set to 1 if any of this port's Connected, Bias, Disabled or Fault bits change state.
Fault	1	R/W	0	Set to 1 if an error occurs during Suspend/Resume. Writing 1 to this bit clears it to 0. Writing 0 has no effect.
Reserved	-	R	000...	Reserved. Read as 0.

2.3 Vendor ID Page (Page 001)

Figure 2-3. Vendor ID Page

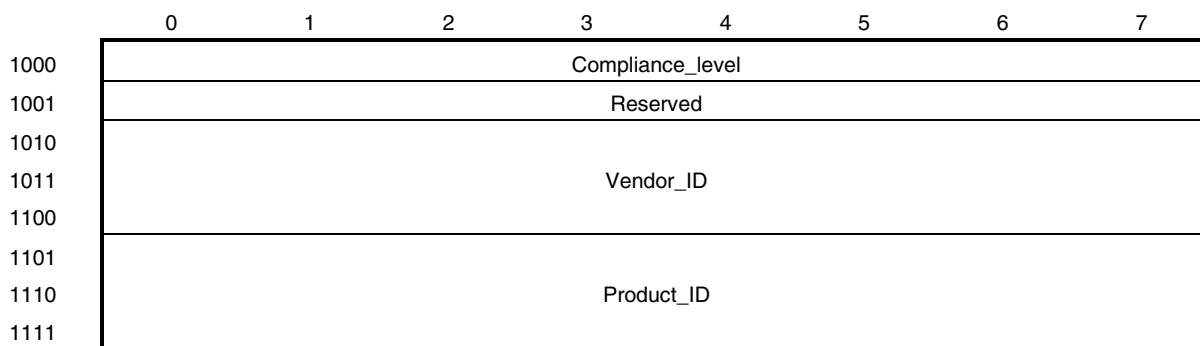

Table 2-3. Bit Field Description

Field	Size	R/W	Reset value	Description
Compliance_level	8	R	00000001	According to IEEE1394a-2000.
Vendor_ID	24	R	00004CH	Company ID Code value, NEC IEEE OUI.
Product_ID	24	R		Product code.
Reserved	-	R	000...	Reserved. Read as 0.

2.4 Vendor Dependent Page (Page 111 : Port\_select 0001)

Figure 2-4. Vendor Dependent Page

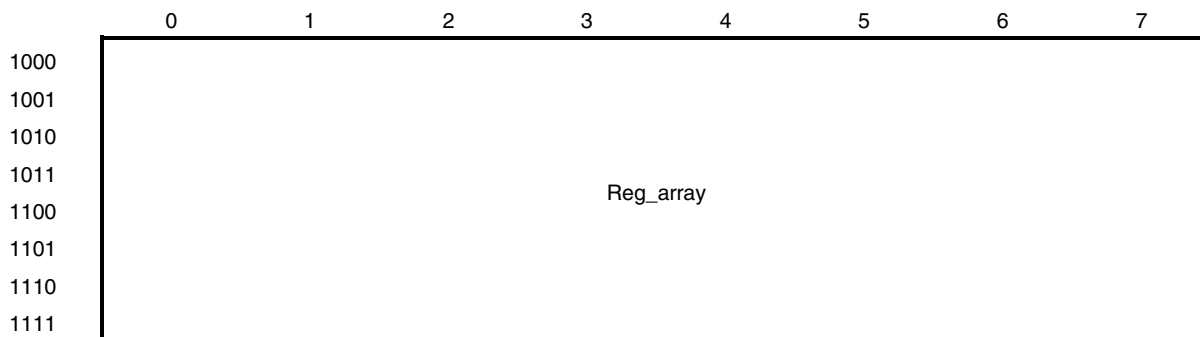

Table 2-4. Bit Field Description

Field	Size	R/W	Reset value	Description
Reg_array	64	R/W	0	This register array is possible R/W.

3. CONFIGURATION REGISTERS

3.1 PCI Bus Mode Configuration Register (CARD\_ON = Low)

31	24 23	16 15	08 07	00		
Device ID		Vendor ID				00H
Status		Command				04H
Class Code			Revision ID			08H
BIST	Header Type	Latency Timer	Cache Line Size			0CH
Base Address 0						10H
Reserved						14H
Reserved						18H
Reserved						1CH
Reserved						20H
Reserved						24H
Reserved						28H
Subsystem ID			Subsystem Vendor ID			2CH
Reserved						30H
Reserved				Cap_Ptr		34H
Reserved						38H
Max_Lat	Min_Gnt	Interrupt Pin	Interrupt Line			3CH
PCI_OHCI_Control						40H
Reserved						44H
Reserved						48H
Reserved						4CH
Reserved						50H
Reserved						54H
Reserved						58H
Reserved						5CH
Power Management Capabilities		Next_Item_Ptr	Cap_ID			60H
Reserved		Power Management Control/Status				64H
Reserved						68H FCH

**3.1.1 Offset\_00 Vendor ID Register**

This register identifies the manufacturer of the μPD72873. The ID is assigned by the PCI\_SIG committee.

Bits	R/W	Description
15-0	R	Constant value of 1033H.

**3.1.2 Offset\_02 Device ID Register**

This register identifies the type of the device for the μPD72873. The ID is assigned by NEC Corporation.

Bits	R/W	Description
15-0	R	Constant value of 00E7H.

**3.1.3 Offset\_04 Command Register**

The register provides control over the device’s ability to generate and respond to PCI cycles.

Bits	R/W	Description
0	R	<b>I/O enable</b> Constant value of 0. The μPD72873 does not respond to PCI I/O accesses.
1	R/W	<b>Memory enable</b> Default value of 1. It defines if the μPD72873 responds to PCI memory accesses. This bit should be set to one upon power-up reset. 0: The μPD72873 does not respond to PCI memory cycles 1: The μPD72873 responds to PCI memory cycles
2	R/W	<b>Master enable</b> Default value of 1. It enables the μPD72873 as bus-master on the PCI-bus. 0: The μPD72873 cannot generate PCI accesses by being a bus-master 1: The μPD72873 is capable of acting as a bus-master
3	R	<b>Special cycle monitor enable</b> Constant value of 0. The special cycle monitor is always disabled.
4	R/W	<b>Memory write and invalidate enable</b> Default value of 0. It enables Memory Write and Invalidate Command generation. 0: Memory write must be used 1: The μPD72873, when acts as PCI master, can generate the command
5	R	<b>VGA™ color palette invalidate enable</b> Constant value of 0. VGA color palette invalidate is always disabled.
6	R/W	<b>Parity error response</b> Default value of 0. It defines if the μPD72873 responds to $\overline{\text{PERR}}$ . 0: Ignore parity error 1: Respond to parity error
7	R	<b>Stepping enable</b> Constant value of 0. Stepping is always disabled.
8	R/W	<b>System error enable</b> Default value of 0. It defines if the μPD72873 responds to $\overline{\text{SERR}}$ . 0: Disable system error checking 1: Enable system error checking
9	R	<b>Fast back-to-back enable</b> Constant value of 0. Fast back-to-back transactions are only allowed to the same agent.
15-10	R	<b>Reserved</b> Constant value of 000000.

3.1.4 Offset\_06 Status Register

This register tracks the status information of PCI-bus related events which are relevant to the μPD72873. “Read” and “Write” are handled somewhat differently.

Bits	R/W	Description
3-0	R	<b>Reserved</b> Constant value of 0000.
4	R	<b>New capabilities</b> Constant value of 1. It indicates the existence of the Capabilities List.
6,5	R	<b>Reserved</b> Constant value of 00.
7	R	<b>Fast back-to-back capable</b> Constant value of 1. It indicates that the μPD72873, as a target, cannot accept fast back-to-back transactions when the transactions are not to the same agent.
8	R/W	<b>Signaled parity error</b> Default value of 0. It indicates the occurrence of any “Data Parity”. 0: No parity detected (default) 1: Parity detected
10,9	R	<b>DEVSEL timing</b> Constant value of 01. These bits define the decode timing for $\overline{\text{DEVSEL}}$ . 0: Fast (1 cycle) 1: Medium (2 cycles) 2: Slow (3 cycles) 3: undefined
11	R/W	<b>Signaled target abort</b> Default value of 0. This bit is set by a target device whenever it terminates a transaction with “Target Abort”. 0: The μPD72873 did not terminate a transaction with Target Abort 1: The μPD72873 has terminated a transaction with Target Abort
12	R/W	<b>Received target abort</b> Default value of 0. This bit is set by a master device whenever its transaction is terminated with a “Target Abort”. 0: The μPD72873 has not received a Target Abort 1: The μPD72873 has received a Target Abort from a bus-master
13	R/W	<b>Received master abort</b> Default value of 0. This bit is set by a master device whenever its transaction is terminated with “Master Abort”. The μPD72873 asserts “Master Abort” when a transaction response exceeds the time allocated in the latency timer field. 0: Transaction was not terminated with a Master Abort 1: Transaction has been terminated with a Master Abort
14	R/W	<b>Signaled system error</b> Default value of 0. It indicates that the assertion of $\overline{\text{SERR}}$ by the μPD72873. 0: System error was not signaled 1: System error was signaled
15	R/W	<b>Received parity error</b> Default value of 0. It indicates the occurrence of any $\overline{\text{PERR}}$ . 0: No parity error was detected 1: Parity error was detected

**3.1.5 Offset\_08 Revision ID Register**

This register specifies a revision number assigned by NEC Corporation for the μPD72873.

Bits	R/W	Description
7-0	R	Default value of 01H. It specifies the silicon revision. It will be incremented for subsequent silicon revisions.

**3.1.6 Offset\_09 Class Code Register**

This register identifies the class code, sub-class code, and programming interface of the μPD72873.

Bits	R/W	Description
7-0	R	Constant value of 10H. It specifies an IEEE1394 OHCI-compliant Host Controller.
15-8	R	Constant value of 00H. It specifies an “IEEE1394” type.
23-16	R	Constant value of 0CH. It specifies a “Serial Bus Controller”.

**3.1.7 Offset\_0C Cache Line Size Register**

This register specifies the system cache line size, which is PC-host system dependent, in units of 32-bit words. The following cache line sizes are supported: 2, 4, 8, 16, 32, 64, and 128. All other values will be recognized as 0, i.e. cache disabled.

Bits	R/W	Description
7-0	R/W	Default value of 00H.

**3.1.8 Offset\_0D Latency Timer Register**

This register defines the maximum amount of time that the μPD72873 is permitted to retain ownership of the bus after it has acquired bus ownership and initiated a subsequent transaction.

Bits	R/W	Description
7-0	R/W	Default value of 00H. It specifies the number of PCI-bus clocks that the μPD72873 may hold the PCI bus as a bus-master.

**3.1.9 Offset\_0E Header Type Register**

Bits	R/W	Description
7-0	R	Constant value of 00H. It specifies a single function device.

**3.1.10 Offset\_0F BIST Register**

Bits	R/W	Description
7-0	R	Constant value of 00H. It specifies whether the device is capable of Built-in Self Test.

**3.1.11 Offset\_10 Base Address 0 Register**

This register specifies the base memory address for accessing all the “Operation registers” (i.e. control, configuration, and status registers) of the μPD72873, while the BIOS is expected to set this value during power-up reset.

Bits	R/W	Description
11-0	R	Constant value of 000H. These bits are “read-only”.
31-12	R/W	-

**3.1.12 Offset\_2C Subsystem Vendor ID Register**

This register identifies the subsystem that contains the NEC’s μPD72873 function. While the ID is assigned by the PCI\_SIG committee, the value should be loaded into the register from the external serial ROM after power-up reset. Access to this register through PCI-bus is prohibited.

Bits	R/W	Description
15-0	R	Default value of 1033H.

**3.1.13 Offset\_2E Subsystem ID Register**

This register identifies the type of the subsystem that contains the NEC’s μPD72873 function. While the ID is assigned by the manufacturer, the value should be loaded into the register from the external serial EEPROM after power-up reset. Access to this register through PCI-bus is prohibited.

Bits	R/W	Description
15-0	R	Default value of 00E7H.

**3.1.14 Offset\_34 Cap\_Ptr Register**

This register points to a linked list of additional capabilities specific to the μPD72873, the NEC’s implementation of the 1394 OHCI specification.

Bits	R/W	Description
7-0	R	Constant value of 60H. The value represents an offset into the μPD72873’s PCI Configuration Space for the location of the first item in the New Capabilities Linked List.

**3.1.15 Offset\_3C Interrupt Line Register**

This register provides the interrupt line routing information specific to the μPD72873, the NEC’s implementation of the 1394 OHCI specification.

Bits	R/W	Description
7-0	R/W	Default value of 00H. It specifies which input of the host system interrupt controller the interrupt pin of the μPD72873 is connected to.

**3.1.16 Offset\_3D Interrupt Pin Register**

This register provides the interrupt line routing information specific to the μPD72873, the NEC's implementation of the 1394 OHCI specification.

Bits	R/W	Description
7-0	R	Constant value of 01H. It specifies PCI $\overline{INTA}$ is used for interrupting the host system.

**3.1.17 Offset\_3E Min\_Gnt Register**

This register specifies how long of a burst period the μPD72873 needs, assuming a clock rate of 33 MHz. Resolution is in units of ¼ μs. The value should be loaded into the register from the external serial EEPROM upon power-up reset, and access to this register through PCI-bus is prohibited.

Bits	R/W	Description
7-0	R	Default value of 00H. Its value contributes to the desired setting for Latency Timer value.

**3.1.18 Offset\_3F Max\_Lat Register**

This register specifies how often the μPD72873 needs to gain access to the PCI-bus, assuming a clock rate of 33 MHz. Resolution is in units of ¼ μs. The value should be loaded into the register from the external serial EEPROM after hardware reset, and access to this register through PCI-bus is prohibited.

Bits	R/W	Description
7-0	R	Default value of 00H. Its value contributes to the desired setting for Latency Timer value.

**3.1.19 Offset\_40 PCI\_OHCI\_Control Register**

This register specifies the control bits that are IEEE1394 OHCI specific. Vendor options are not allowed in this register. It is reserved for OHCI use only.

Bits	R/W	Description
0	R/W	<b>PCI global SWAP</b> Default value of 0. When this bit is 1, all quadrates read from and written to the PCI Interface are byte swapped, thus a "PCI Global Swap". PCI addresses for expansion ROM and PCI Configuration registers, are, however, unaffected by this bit. This bit is not required for motherboard implementations.
31-1	R	<b>Reserved</b> Constant value of all 0.

**3.1.20 Offset\_60 Cap\_ID & Next\_Item\_Ptr Register**

The Cap\_ID signals that this item in the Linked List is the registers defined for PCI Power Management, while the Next\_Item\_Ptr describes the location of the next item in the μPD72873's Capability List.

Bits	R/W	Description
7-0	R	<b>Cap_ID</b> Constant value of 01H. The default value identified the Link List item as being the PCI Power Management registers, while the ID value is assigned by the PCI SIG.
15-8	R	<b>Next_Item_Ptr</b> Constant value of 00H. It indicated that there are no more items in the Link List.

**3.1.21 Offset\_62 Power Management Capabilities Register**

This is a 16-bit read-only register that provides information on the power management capabilities of the μPD72873.

Bits	R/W	Description
2-0	R	<b>Version</b> Constant value of 010. The power management registers are implemented as defined in revision 1.1 of PCI Bus Power Management Interface Specification.
3	R	<b>PME clock</b> Constant value of 0.
4	R	<b>Reserved</b> Constant value of 0.
5	R	<b>DSI</b> Constant value of 0.
8-6	R	<b>Auxiliary Power</b> Default value of 000. This field reports the Vaux power requirements for the μPD72873. This data is programable from EEPROM. 111 – 375 mA maximum current required for a 3.3 Vaux, 110 – 320 mA maximum current required for a 3.3 Vaux, 101 – 270 mA maximum current required for a 3.3 Vaux, 100 – 220 mA maximum current required for a 3.3 Vaux, 011 – 160 mA maximum current required for a 3.3 Vaux, 010 – 100 mA maximum current required for a 3.3 Vaux, 001 – 55 mA maximum current required for a 3.3 Vaux, 000 – 0 (self powered)
9	R	<b>D1_support</b> Constant value of 1. The μPD72873 supports the D1 Power Management state.
10	R	<b>D2_support</b> Constant value of 1. The μPD72873 supports the D2 Power Management state.
15-11	R	<b>PME_support</b> D3SUP = 'High' : Constant value of 11111. D3SUP = 'Low' : Constant value of 01111. This field indicates the power states in which the μPD72873 may assert $\overline{\text{PME}}$ . A value of "0" for any bit indicates that the function is not capable of asserting the $\overline{\text{PME}}$ signal while in that power state. bit (11) – PME_D0. $\overline{\text{PME}}$ can be asserted from D0. bit (12) – PME_D1. $\overline{\text{PME}}$ can be asserted from D1. bit (13) – PME_D2. $\overline{\text{PME}}$ can be asserted from D2. bit (14) – PME_D3hot. $\overline{\text{PME}}$ can be asserted from D3hot. bit (15) – PME_D3cold. $\overline{\text{PME}}$ can be asserted from D3cold.

**3.1.22 Offset\_64 Power Management Control/Status Register**

This is a 16-bit register that provides control status information of the μPD72873.

Bits	R/W	Description
1,0	R/W	<p><b>PowerState</b> Default value is undefined. This field is used both to determine the current power state of the μPD72873 and to set the μPD72873 into a new power state.</p> <p>00: D0 (DMA contexts: ON, Link Layer: ON, PME will be asserted upon INTA being active)</p> <p>01: D1 (DMA contexts: OFF, Link Layer: ON, PME will be asserted upon INTA being active)</p> <p>10: D2 (DMA contexts: OFF, Link Layer: OFF, LPS: OFF, PME will be asserted upon LinkON being active)</p> <p>11: D3 (DMA contexts: OFF, Link Layer: OFF, LPS: OFF, PME will be asserted upon LinkON being active)</p> <p>The LPS is a PHY/Link interface signal and is defined in P1394a-2000. It is an internal signal in the μPD72873.</p>
7-2	R	<b>Reserved</b> Constant value of 000000.
8	R/W	<b>PME_En</b> Default value of 0. This field is used to enable the specific power management features of the μPD72873.
12-9	R	<b>Data_Select</b> Constant value of 0000.
14,13	R	<b>Data_Scale</b> Constant value of 00.
15	R/W	<b>PME_Status</b> Default value is undefined. A write of '1' clears this bit, while a write of '0' is ignored.

3.2 CardBus Mode Configuration Register (CARD\_ON = High)

31	24 23	16 15	08 07	00	
Device ID		Vendor ID			00H
Status		Command			04H
Class Code			Revision ID		08H
BIST	Header Type	Latency Timer	Cache Line Size		0CH
Base Address 0					10H
Base Address 1 (Cardbus Status Reg) <i>Note</i>					14H
Base Address 2 (Cardbus Status Reg) <i>Note</i>					18H
Reserved					1CH
Reserved					20H
Reserved					24H
Cardbus CIS Pointer <i>Note</i>					28H
Subsystem ID		Subsystem Vendor ID			2CH
Reserved					30H
Reserved			Cap_Ptr		34H
Reserved					38H
Max_Lat	Min_Gnt	Interrupt Pin	Interrupt Line		3CH
PCI_OHCI_Control					40H
Reserved					44H
Reserved					48H
Reserved					4CH
Reserved					50H
Reserved					54H
Reserved					58H
Reserved					5CH
Power Management Capabilities		Next_Item_Ptr	Cap_ID		60H
Reserved		Power Management Control/Status			64H
Reserved					68H
Reserved					6CH
Reserved					70H
Reserved					74H
Reserved					78H
Reserved					7CH
CIS Area <i>Note</i>					80H FCH

**Note** Different from PCI Bus Mode Configuration Register.

**3.2.1 Offset\_14/18 Base Address 1/2 Register (Cardbus Status Registers)**

Bits	R/W	Description
7-0	R	Constant value of 00.
31-8	R/W	-

**(1) Function Event Register (FER) (Base Address 1 (2) + 0H)**

Bits	R/W	Description
0	R	Write Protect (No Use). Read only as '0'
1	R	Ready Status (No Use). Read only as '0'
2	R	Battery Voltage Detect 2 (No Use). Read only as '0'
3	R	Battery Voltage Detect 1 (No Use). Read only as '0'
4	R/W	General Wake Up
14-5	R	Reserved. Read only as '0'
15	R/W	Interrupt
31-16	R	Reserved. Read only as '0'

**(2) Function Event Mask Register (FEMR) (Base Address 1 (2) + 4H)**

Bits	R/W	Description
0	R	Write Protect (No Use). Read only as '0'
1	R	Ready Status (No Use). Read only as '0'
2	R	Battery Voltage Detect 2 (No Use). Read only as '0'
3	R	Battery Voltage Detect 1 (No Use). Read only as '0'
4	R/W	General Wake Up Mask
5	R	BAM. Read only as '0'
6	R	PWM. Read only as '0'
13-7	R	Reserved. Read only as '0'
14	R/W	Wake Up Mask
15	R/W	Interrupt
31-16	R	Reserved. Read only as '0'

**(3) Function Reset Status Register (FRSR) (Base Address 1 (2) + 8H)**

Bits	R/W	Description
0	R	Write Protect (No Use). Read only as '0'
1	R	Ready Status (No Use). Read only as '0'
2	R	Battery Voltage Detect 2 (No Use). Read only as '0'
3	R	Battery Voltage Detect 1 (No Use). Read only as '0'
4	R/W	General Wake Up Mask
14-5	R	Reserved. Read only as '0'
15	R/W	Interrupt
31-16	R	Reserved. Read only as '0'

**(4) Function Force Event Register (FFER) (Base Address 1 (2) + CH)**

Bits	R/W	Description
0	R	Write Protect (No Use). Read only as '0'
1	R	Ready Status (No Use). Read only as '0'
2	R	Battery Voltage Detect 2 (No Use). Read only as '0'
3	R	Battery Voltage Detect 1 (No Use). Read only as '0'
4	R/W	General Wake Up Mask
14-5	-	No Use
15	R/W	Interrupt
31-16	R	Reserved. Read only as '0'

**3.2.2 Offset\_28 Cardbus CIS Pointer**

This register specifies start memory address of the Cardbus CIS Area.

Bits	R/W	Description
31-0	R	Starting Pointer of CIS Area. Constant value of 00000080H.

**3.2.3 Offset\_80 CIS Area**

The μPD72873 supports external Serial ROM (AT24C02 compatible) interface.

CIS Area Register can be loaded from external Serial ROM in the CIS area when CARD\_ON is 1.

4. PHY FUNCTION

4.1 Cable Interface

4.1.1 Connections

Figure 4-1. Cable Interface

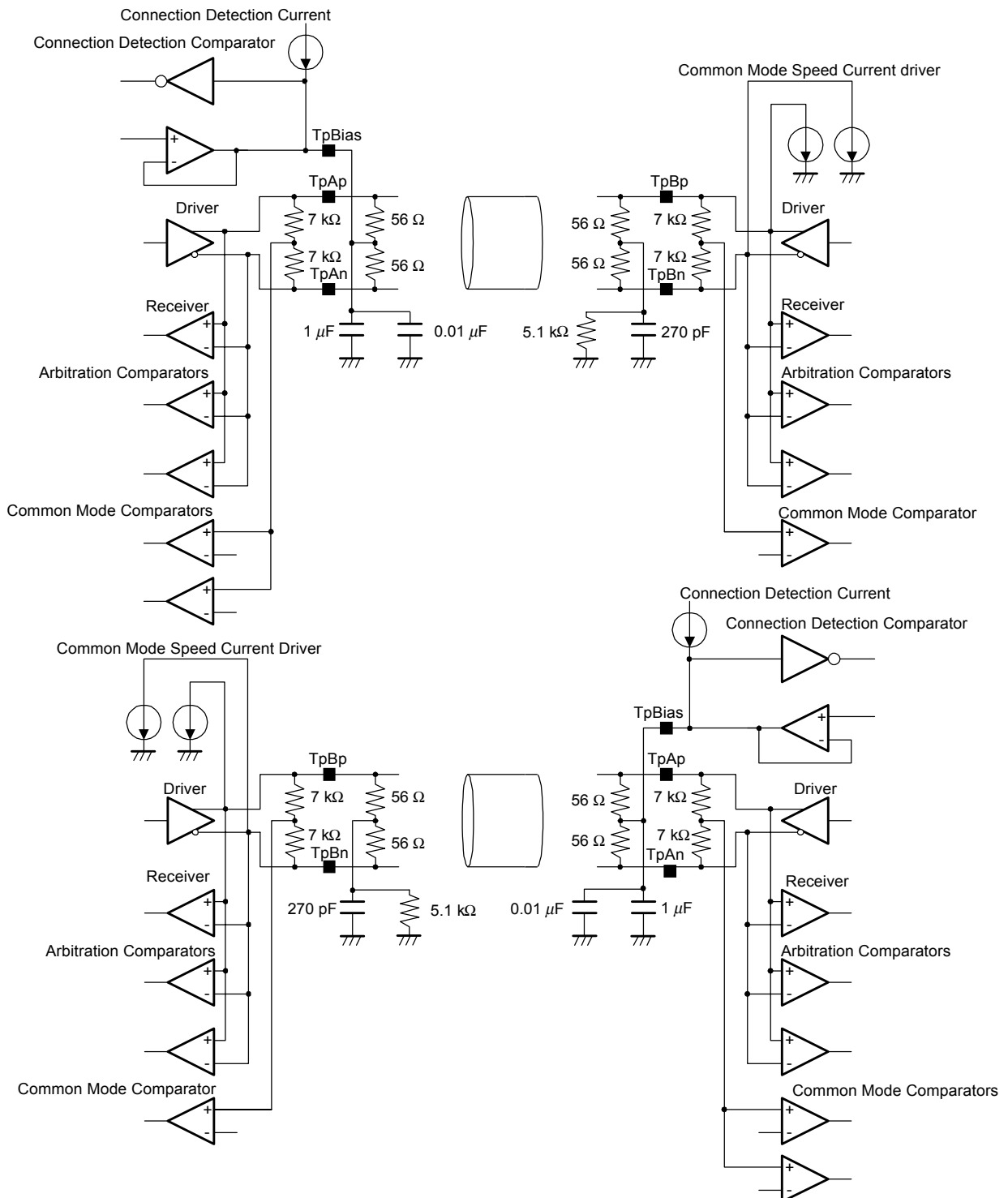

#### 4.1.2 Cable Interface Circuit

Each port is configured with two twisted-pairs of TpA and TpB.

TpA and TpB are used to monitor the state of the Transmit/Receive line, control signals, data and cables.

During transmission to the IEEE1394 bus, the Data/Strobe signal received from the Link layer controller is encoded, converted from parallel to serial and transmitted.

While receiving from the IEEE1394 bus, the Data/Strobe signal from TpA, TpB is converted from serial to parallel after synchronization by SCLK <sup>Note</sup>, then transmitted to the Link layer controller in 2/4/8 bits according to the data rate of 100/200/400 Mbps.

The bus arbitration for TpA and TpB and the state of the line are monitored by the built-in comparator. The state of the 1394 bus is transmitted to the state machine in the LSI.

**Note** The SCLK is a PHY/Link interface signal and is defined in P1394a-2000. It is an internal signal in the  $\mu$ PD72873.

#### 4.1.3 CPS

Connect an external resistor of 390 k $\Omega$  between the CPS pin and the power cable, and an external resistor of 100 k $\Omega$  between the CPS pin and the GND to monitor the power of the power cable.

If the cable power falls under 7.5 V there is an indication to the Link layer that the power has failed.

#### 4.1.4 Unused Ports

TpAp, TpAn : Not connected

TpBp, TpBn : AGND

TpBias : Not connected

### 4.2 PLL and Crystal Oscillation Circuit

#### 4.2.1 Crystal Oscillation Circuit

To supply the clock of 24.576 MHz  $\pm$  100 ppm, use an external capacitor of 10 pF and a crystal of 50 ppm.

#### 4.2.2 PLL

The crystal oscillator multiplies the 24.576 MHz frequency by 16 (393.216 MHz).

### 4.3 PC0 to PC2

The PC0 to PC2 pin corresponds to the power field of the Self\_ID packet and Pwr\_class in the PHY register. Refer to Section 4.3.4.1 of the IEEE1394-1995 specification for information regarding the Pwr\_class. The value of Pwr can be changed with software through the Link layer; this pin sets the initial value during Power-on Reset. Use a pull-up or pull-down resistor of 1 k $\Omega$  based on the application.

### 4.4 $\overline{\text{P\_RESET}}$

Connect an external capacitor of 0.1  $\mu$ F between the pins  $\overline{\text{P\_RESET}}$  and GND. If the voltage drops below 0 V, a reset pulse is generated. All of the circuits are initialized, including the contents of the PHY register.

### 4.5 RI0, RI1

Connect an external resistor of 9.1 k $\Omega$   $\pm$  0.5 % to limit the LSI's current.

5. ELECTRICAL SPECIFICATIONS

Absolute Maximum Ratings

Parameter	Symbol	Condition	Rating	Unit
Power supply voltage	$V_{DD}$		-0.5 to +4.6	V
Input voltage	$V_i$	LVTTL @ ( $V_i < 0.5 V + V_{DD}$ )	-0.5 to +4.6	V
		PCI @ ( $V_i < 3.0 V + V_{DD}$ )	-0.5 to +6.6	V
Output voltage	$V_o$	LVTTL @ ( $V_o < 0.5 V + V_{DD}$ )	-0.5 to +4.6	V
		PCI @ ( $V_o < 3.0 V + V_{DD}$ )	-0.5 to +6.6	V
Operating ambient temperature	$T_A$		0 to +70	°C
Storage temperature	$T_{stg}$		-65 to +150	°C

**Caution** Product quality may suffer if the absolute maximum rating is exceeded even momentarily for any parameter. That is, the absolute maximum ratings are rated values at which the product is on the verge of suffering physical damage, and therefore the product must be used under conditions that ensure that the absolute maximum ratings are not exceeded.

Recommended Operating Ranges

Parameter	Symbol	Condition	Rating	Unit
Power supply voltage	$V_{DD}$	Used to clamp reflection on PCI bus.	4.5 to 5.5	V
			3.0 to 3.6	V
Operating ambient temperature	$T_A$		0 to +70	°C

**DC Characteristics ( $V_{DD} = 3.3\text{ V} \pm 10\%$ ,  $V_{SS} = 0\text{ V}$ ,  $T_A = 0\text{ to }+70^\circ\text{C}$ )**

Parameter	Symbol	Condition	MIN.	TYP.	MAX.	Unit
High-level input voltage	$V_{IH}$		2.0		$V_{DD}+0.5$	V
Low-level input voltage	$V_{IL}$		-0.5		+0.8	V
High-level output current	$I_{OH}$	$V_{OH} = 2.4\text{ V}$ , GROM_SDA, GROM_SCL	-6			mA
Low-level output current	$I_{OL}$	$V_{OL} = 0.4\text{ V}$ , GROM_SDA, GROM_SCL	6			mA
Input leakage current	$I_L$	$V_{IN} = V_{DD}$ or GND			$\pm 10.0$	μA
<b>PCI interface</b>						
High-level input voltage	$V_{IH}$		2.0		5.5	V
Low-level input voltage	$V_{IL}$		-0.5		+0.8	V
High-level output current	$I_{OH}$	$V_{OH} = 2.4\text{ V}$	-2			mA
Low-level output current	$I_{OL}$	$V_{OL} = 0.4\text{ V}$	9			mA
Input leakage current	$I_L$	$V_{IN} = V_{DD}$ or GND			$\pm 10.0$	μA
<b>Cable interface</b>						
Differential input voltage	$V_{ID}$	Cable input, 100 Mbps operation	142		260	mV
		Cable input, 200 Mbps operation	132		260	mV
		Cable input, 400 Mbps operation	118		260	mV
TpB common mode input voltage	$V_{ICM}$	100 Mbps speed signaling off	1.165		2.515	V
		200 Mbps speed signaling	0.935		2.515	V
		400 Mbps speed signaling	0.523		2.515	V
Differential output voltage	$V_{OD}$	Cable output (Test load 55 Ω)	172.0		265.0	mV
TpA common mode output voltage	$V_{OCM}$	100 Mbps speed signaling off	1.665		2.015	V
		200 Mbps speed signaling	1.438		2.015	V
		400 Mbps speed signaling	1.030		2.015	V
TpA common mode output current	$I_{CM}$	100 Mbps speed signaling off	-0.81		+0.44	mA
		200 Mbps speed signaling	-4.84		-2.53	mA
		400 Mbps speed signaling	-12.40		-8.10	mA
Power status threshold voltage	$V_{TH}$	CPS			7.5	V
TpBias output voltage	$V_{TPBIAS}$		1.665		2.015	V

**Remarks 1.** Digital core runs at 3.3 V.

2. PCI Interface can run at 5 or 3.3 V, depending on the choice of 5 V-PCI or 3.3 V-PCI.
3. All other I/Os are 3.3 V driving, and 5 V tolerant.
4. 5 V are used only for 5 V-PCI clamping diode.

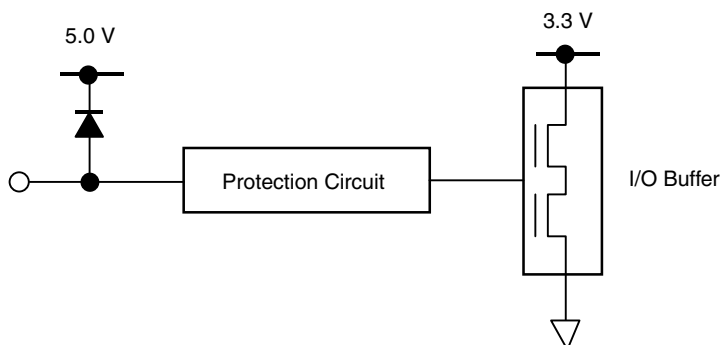

**AC Characteristics****PCI Interface**

See PCI local bus specification Revision 2.2.

**Serial ROM Interface**

See AT24C01A/02/04/08/16 Spec. Sheet.

★ 6. PACKAGE DRAWING

120-PIN PLASTIC TQFP (FINE PITCH) (14x14)

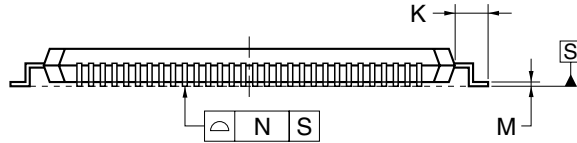
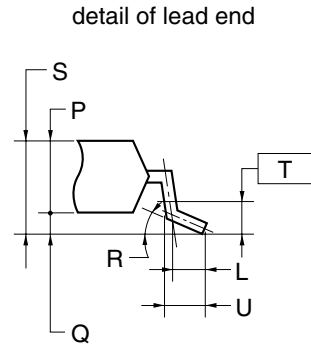
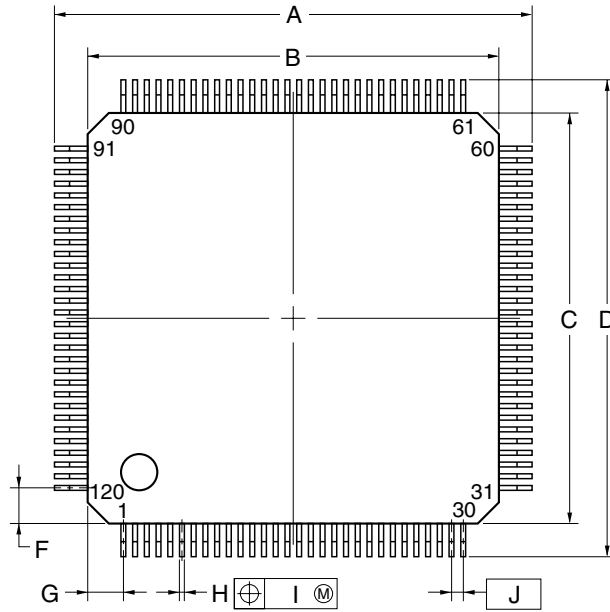

NOTE

Each lead centerline is located within 0.07 mm of its true position (T.P.) at maximum material condition.

ITEM	MILLIMETERS
A	16.00±0.20
B	14.00±0.20
C	14.00±0.20
D	16.00±0.20
F	1.20
G	1.20
H	0.18±0.05
I	0.07
J	0.40 (T.P.)
K	1.00±0.20
L	0.50
M	0.17 <sup>+0.03</sup> <sub>-0.07</sub>
N	0.08
P	1.00±0.05
Q	0.10±0.05
R	3° <sup>+4</sup> <sub>-3</sub>
S	1.20MAX.
T	0.25

P120GC-40-YEB

**7. RECOMMENDED SOLDERING CONDITIONS**

The μPD72873 should be soldered and mounted under the following recommended conditions.

For the details of the recommended soldering conditions, refer to the document **Semiconductor Device Mounting Technology Manual (C10535E)**.

For soldering methods and conditions other than those recommended below, contact your NEC sales representative.

**Table 7-1. Surface Mounting Type Soldering Conditions**

**μPD72873GC-YEB: 120-pin plastic TQFP (Fine pitch) (14 x 14)**

Soldering Method	Soldering Conditions	Recommended Condition Symbol
Infrared reflow	Package peak temperature: 235°C, Time: 30 sec. Max. (at 210°C or higher). Count: three times or less Exposure limit: 3 days <sup>Note</sup> (after that prebake at 125°C for 10 hours)	IR35-103-3
Partial heating	Pin temperature: 300°C Max., Time: 3 sec. Max. (per pin row)	—

**Note** After opening the dry pack, store it at 25°C or less and 65% RH or less for the allowable storage period.

[MEMO]

[MEMO]

[MEMO]

## NOTES FOR CMOS DEVICES

**① PRECAUTION AGAINST ESD FOR SEMICONDUCTORS**

Note:

Strong electric field, when exposed to a MOS device, can cause destruction of the gate oxide and ultimately degrade the device operation. Steps must be taken to stop generation of static electricity as much as possible, and quickly dissipate it once, when it has occurred. Environmental control must be adequate. When it is dry, humidifier should be used. It is recommended to avoid using insulators that easily build static electricity. Semiconductor devices must be stored and transported in an anti-static container, static shielding bag or conductive material. All test and measurement tools including work bench and floor should be grounded. The operator should be grounded using wrist strap. Semiconductor devices must not be touched with bare hands. Similar precautions need to be taken for PW boards with semiconductor devices on it.

**② HANDLING OF UNUSED INPUT PINS FOR CMOS**

Note:

No connection for CMOS device inputs can be cause of malfunction. If no connection is provided to the input pins, it is possible that an internal input level may be generated due to noise, etc., hence causing malfunction. CMOS devices behave differently than Bipolar or NMOS devices. Input levels of CMOS devices must be fixed high or low by using a pull-up or pull-down circuitry. Each unused pin should be connected to  $V_{DD}$  or GND with a resistor, if it is considered to have a possibility of being an output pin. All handling related to the unused pins must be judged device by device and related specifications governing the devices.

**③ STATUS BEFORE INITIALIZATION OF MOS DEVICES**

Note:

Power-on does not necessarily define initial status of MOS device. Production process of MOS does not define the initial operation status of the device. Immediately after the power source is turned ON, the devices with reset function have not yet been initialized. Hence, power-on does not guarantee out-pin levels, I/O settings or contents of registers. Device is not initialized until the reset signal is received. Reset operation must be executed immediately after power-on for devices having reset function.

**EEPROM and Firewarden are trademarks of NEC Corporation.**

**VGA is a trademark of IBM Corporation.**

- **The information in this document is current as of April, 2002. The information is subject to change without notice. For actual design-in, refer to the latest publications of NEC's data sheets or data books, etc., for the most up-to-date specifications of NEC semiconductor products. Not all products and/or types are available in every country. Please check with an NEC sales representative for availability and additional information.**
  - No part of this document may be copied or reproduced in any form or by any means without prior written consent of NEC. NEC assumes no responsibility for any errors that may appear in this document.
  - NEC does not assume any liability for infringement of patents, copyrights or other intellectual property rights of third parties by or arising from the use of NEC semiconductor products listed in this document or any other liability arising from the use of such products. No license, express, implied or otherwise, is granted under any patents, copyrights or other intellectual property rights of NEC or others.
  - Descriptions of circuits, software and other related information in this document are provided for illustrative purposes in semiconductor product operation and application examples. The incorporation of these circuits, software and information in the design of customer's equipment shall be done under the full responsibility of customer. NEC assumes no responsibility for any losses incurred by customers or third parties arising from the use of these circuits, software and information.
  - While NEC endeavours to enhance the quality, reliability and safety of NEC semiconductor products, customers agree and acknowledge that the possibility of defects thereof cannot be eliminated entirely. To minimize risks of damage to property or injury (including death) to persons arising from defects in NEC semiconductor products, customers must incorporate sufficient safety measures in their design, such as redundancy, fire-containment, and anti-failure features.
  - NEC semiconductor products are classified into the following three quality grades:  
"Standard", "Special" and "Specific". The "Specific" quality grade applies only to semiconductor products developed based on a customer-designated "quality assurance program" for a specific application. The recommended applications of a semiconductor product depend on its quality grade, as indicated below. Customers must check the quality grade of each semiconductor product before using it in a particular application.
    - "Standard": Computers, office equipment, communications equipment, test and measurement equipment, audio and visual equipment, home electronic appliances, machine tools, personal electronic equipment and industrial robots
    - "Special": Transportation equipment (automobiles, trains, ships, etc.), traffic control systems, anti-disaster systems, anti-crime systems, safety equipment and medical equipment (not specifically designed for life support)
    - "Specific": Aircraft, aerospace equipment, submersible repeaters, nuclear reactor control systems, life support systems and medical equipment for life support, etc.
- The quality grade of NEC semiconductor products is "Standard" unless otherwise expressly specified in NEC's data sheets or data books, etc. If customers wish to use NEC semiconductor products in applications not intended by NEC, they must contact an NEC sales representative in advance to determine NEC's willingness to support a given application.

(Note)

- (1) "NEC" as used in this statement means NEC Corporation and also includes its majority-owned subsidiaries.
- (2) "NEC semiconductor products" means any semiconductor product developed or manufactured by or for NEC (as defined above).