



Pacific Wireless

2844 Mar Vista Dr. Suite 101
Aptos, CA 95003
TEL (831) 684-2474
FAX (831) 684-2494
www.pacwireless.com

C2304

DATA SHEET

MMDS / ISM / S-Band Downconverter

1800 to 4800 MHz Operation

Features

- 1800 to 4800 MHz RF
- 10 to 900 MHz IF
- 26 dB Gain, 4dB Noise Figure
- Single 5V Supply
- 27 dBm Output IP3
- Separate RF AMP, MIXER/LO AMP and IF AMP cells.
- 75 ohm IF output impedance

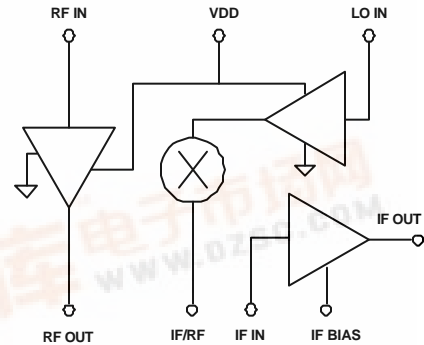

Applications

- 2.4 GHz ISM Band Applications
- MMDS Downconverters
- Wireless Bridges
- Wireless Local Loop Systems
- S Band Receivers
- Wireless LANS and WANS
- Point to Multipoint Receivers
- 2.4GHz Consumer Applications
- Bluetooth Applications
- Upconverters

Description

The C2304 is a flexible high intercept and high gain down conversion GaAs MMIC packaged in a compact 14 pin SOIC package. Each sub-circuit is brought out on separate pins to allow for custom filtering on the IF/Rf mixer interstage or custom matching for specific bands. Broadband parallel feedback networks are used on the gain and LO driver stages and the mixer is a singly balanced, two diode type mixer. The FET source of the IF amplifier stage (IF BIAS) is accessible for AC bypassing which allows for current reduction with DC source degeneration. The gain and DC current is broken up as follows: RF AMP gain = 14dB, current = 22 mA; LO AMP gain = 11dB, current = 28ma; IF AMP gain = 18dB, current = 60 mA, MIXER conversion loss = -6dB. Simple external matching circuits can be implemented for all ports to achieve VSWR's <2:1 over moderate bandwidths of less than 400MHz.

Electrical Characteristics

Typical Specifications for $V_{DD}=5.0V$ $T_A=+25^{\circ}C$

Minimum and Maximum specifications are guaranteed over RF range 2.5GHz – 2.68GHz

Tested in 50Ω input / 75Ω output system, LO=2.278GHz at 5dBm, using matching circuit shown on page 3.

Parameter	Symbol	Conditions	Min	Typ	Max	Units
Conversion Gain	G	LO=5dBm	24.7	26	27.3	dB
Single Sideband Noise Figure	NF	LO=2.278GHz		4		dB
Output IP3	IP3	LO=5dBm		27		dBm
RF Input Return Loss	S_{11}	50Ω input ref.		-12		dB
IF Output Return Loss	S_{22}	75Ω output ref.		-11		dB

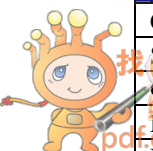

LO Input Return Loss	S_{11}	50 Ω input ref.		-2		dBm
Output Power at 1dB Comp.	P_{1dB}	LO=5dBm		17		dBm
Operating Drain Current	I_{DD}			110		mA
RF OUT to IF/RF Isolation	ISO_{r-i}	LO=5dBm		32		dB
LO IN to IF OUT Isolation	ISO_{l-i}	LO=5dBm		13		dB
LO IN to RF IN Isolation	ISO_{l-r}	LO=5dBm		24		DB
Load VSWR for Input/Output Stability ¹	VSWR	With network on page 3		10:1		
Thermal Resistance	θ_{JC}	Junction to GND lead		75		$^{\circ}\text{C}/\text{W}$

¹ As a separate circuit the IF AMP is conditionally stable for VSWR < 5:1 over 1.5-3.6GHz

Typical Performance Characteristics

(Obtained using external circuit shown on p. 3)

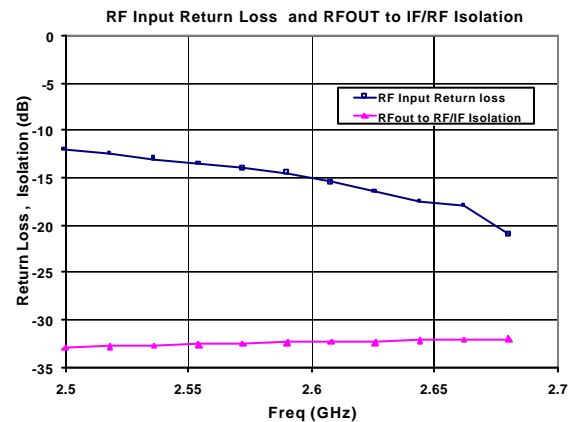
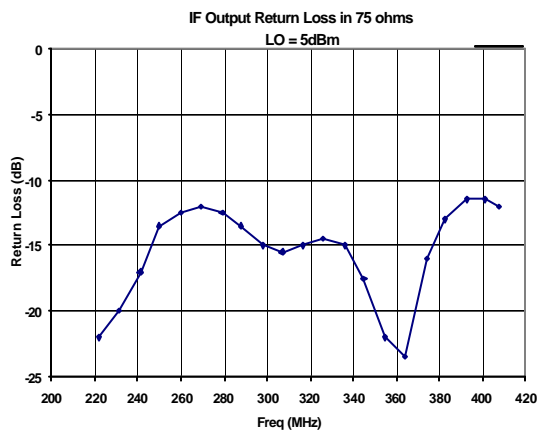
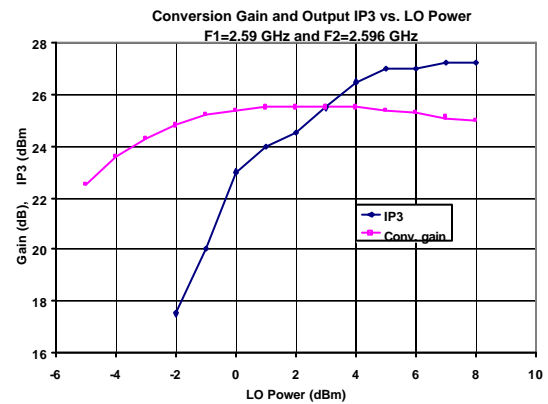
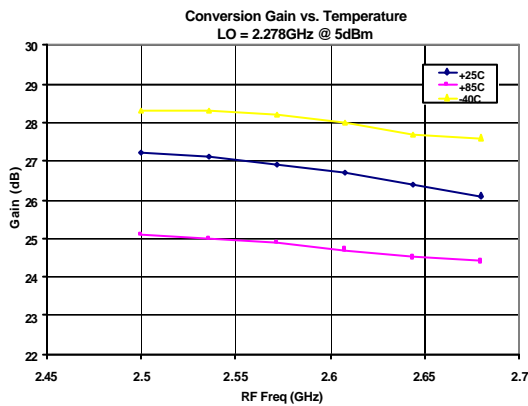

Absolute Maximum Ratings

Characteristic	Symbol	Value	Units
Drain Voltage	$V_{DD1,2}$	+8	V
Bias Current	I_{DS}	200	mA
RF Input Power	P_{IN}	+18	dBm
Power Dissipation	P_{DISS}	1.0	W
Load VSWR	VSWR	10:1	
Operating Temperature	T_{OP}	-40 to +85	$^{\circ}\text{C}$
Junction Temperature	T_J	150	$^{\circ}\text{C}$
Storage Temperature Range	T_{STG}	-65 to +150	$^{\circ}\text{C}$

Caution: Operating beyond specified rating for any of these parameters may cause permanent damage to the device.

Application Information

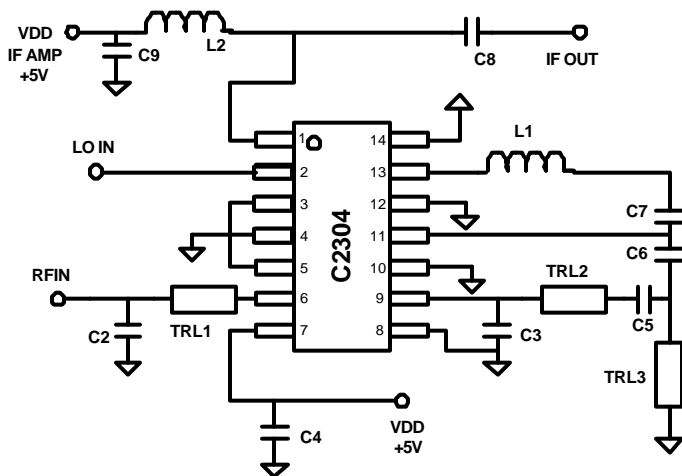

Matching/Diplexing Circuit for 2.5 to 2.68 GHz Operation.

Part	Value/Type	Size
C5	33pF NPO	0603
C2	1pF NPO	0603
C3	0.5pF NPO	0603
C4,C9	0.1uF X7R	0603
C6	1.8pF NPO	0603
C7	270 pF NPO	0603
C8	1000pF X7R	0603
L1	39 nH	0805
L2	560 nH	1008
TRL1	$\theta = 30^\circ, Z_0=110\Omega$	@2.5GHz
TRL2	$\theta = 23^\circ, Z_0=110\Omega$	@2.5GHz
TRL3	$\theta = 28^\circ, Z_0=110\Omega$	@2.5GHz

Recommended LO IN Port Matching

The LO IN port of the C2304 can be matched into 50 ohms with a lossy network. At 3dBm drive, the unmatched port is at $Z = 5 - 15j$ ohms at 2.278 GHz. Also of note is that this impedance varies somewhat with the LO drive level. Therefore a narrow band high Q network is not recommended due to inherent manufacturing variation in LO drive available. The simple network below matches this port over an ~ 10% bandwidth.

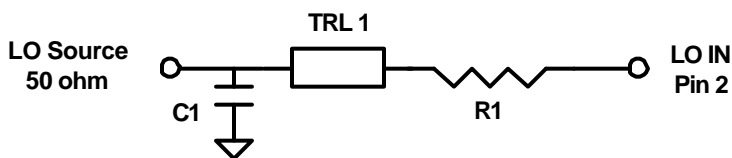

Part	Value/Type	Size
C1	1.8pF NPO	0603
R1	4.3 Ω	0603
TRL1	$\theta = 21^\circ, Z_0=110\Omega$	@2.5GHz

Test Board Layout

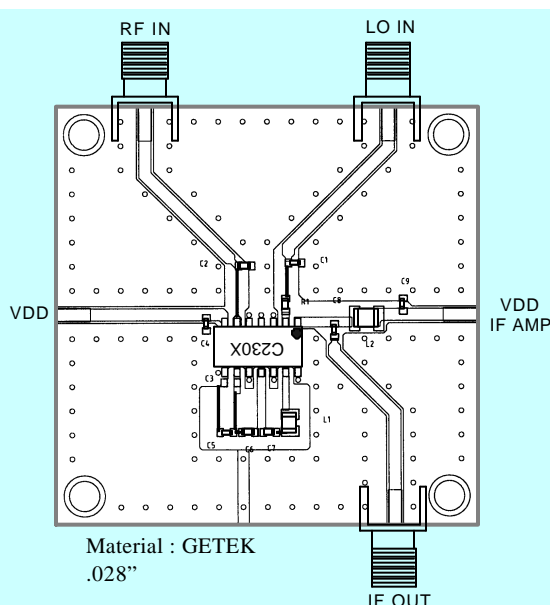

Biasing and Electrical Ground/ Thermal Considerations

Pins 3,4,5,10 and 12 should have ground vias straddling both sides of the pin solder contact. This insures good electrical and thermal grounding. If the IF AMP is run at I_{dss} (DC Grounded IF BIAS pin 14), this pin should be grounded as described above. It is recommended that a continuous ground plane be present under the package to lower pin impedance and maintain similarity with the matching environment used in the schematic in the Application Information section. Bias for the IF amplifier is supplied thru IF OUT pin 14. All ports are DC coupled to the IC. Pins 2,6 and 13 should be kept at 0V DC to maintain proper gate voltages. Pin 9 is internally biased at 5V under normal operation and requires an external DC block.

Package Specifications

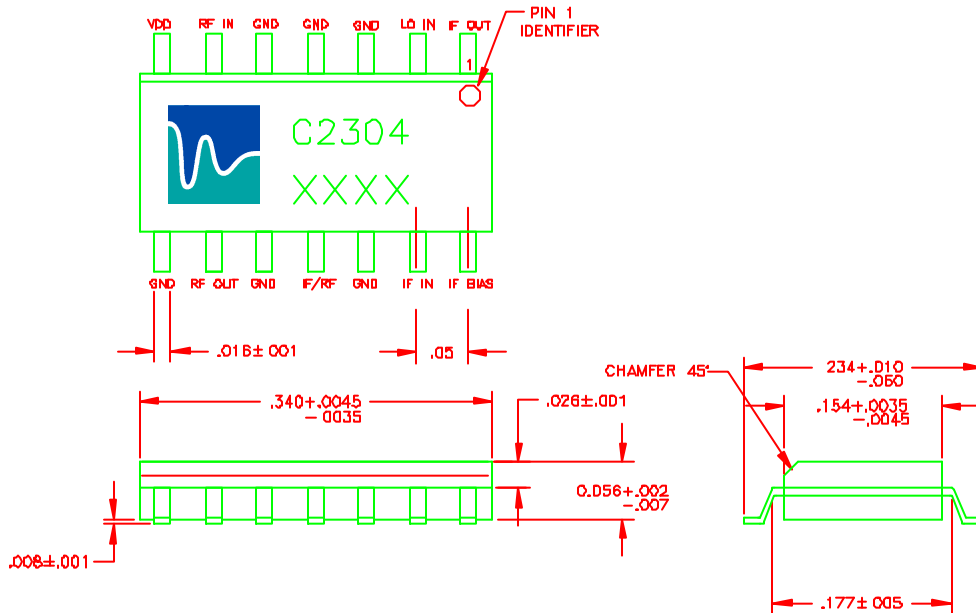

Pin Number	Function
1	IF OUT
2	LO IN
3	GND
4	GND
5	GND
6	RF IN
7	VDD
8	GND
9	RFOUT
10	GND
11	IF/RF
12	GND
13	IF IN
14	IF BIAS

Notes:

- Standard packaging is 14L SOIC tube. Tape and Reel available upon request.
- All shipments F.O.B. Pacific Wireless Aptos, CA 95003

ADVANTAGES OF GAAS MMIC

RF INTEGRATION – LESS COMPONENTS/BOARD SPACE
 GOOD DEVICE MATCHING – NO TWEAKS – LESS TUNING
 GREAT POWER EFFICIENCY AT LOW VOLTAGE
 BETTER LINEARITY AND DISTORTION PERFORMANCE
 SUPERB RADIATION IMMUNITY
 NO LATENT OR CUMMULATIVE ESD EFFECTS
 NO INFANT MORTALITY; NO “WALKING WOUNDED”
 NO BURN-IN NECESSARY

Part Numbers:

Part Number	Description
C2304	1800 to 4800 Downconverter – Tube
C2304TR	1800 to 4800 Downconverter – Tape and Reel

For further information contact:



Pacific Wireless
 2844 Mar Vista Dr. Suite 101
 Aptos, CA 95003
 TEL (831) 684-2474
 FAX (831) 684-2494
www.pacwireless.com