



# MX27C4000

## 4M-BIT [512K x8] CMOS EPROM

### FEATURES

- 512K x 8 organization
- Single +5V power supply
- +12.5V programming voltage
- Fast access time: 90/100/120/150 ns
- Totally static operation
- Completely TTL compatible
- Operating current: 40mA
- Standby current: 100uA
- Package type:
  - 32 pin plastic DIP
  - 32 pin PLCC/SOP
  - 32 pin TSOP

### GENERAL DESCRIPTION

The MX27C4000 is a 5V only, 4M-bit, One Time Programmable Read Only Memory. It is organized as 512K words by 8 bits per word, operates from a single +5 volt supply, has a static standby mode, and features fast single address location programming. All programming signals are TTL levels, requiring a single pulse. For programming outside from the system, existing EPROM

programmers may be used. The MX27C4000 supports a intelligent fast programming algorithm which can result in programming time of less than two minutes.

This EPROM is packaged in industry standard 32 pin dual-in-line packages, 32 lead PLCC, 32 lead SOP, and 32 lead TSOP packages.

### PIN CONFIGURATIONS

#### 32 PDIP/SOP

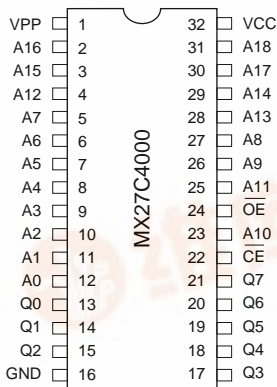

#### 32 PLCC

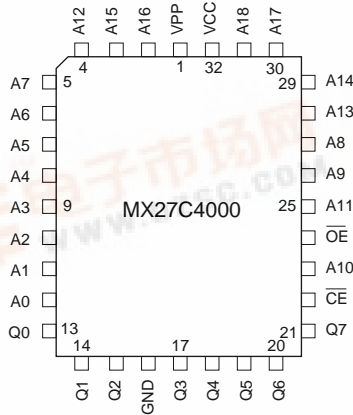

#### 32 TSOP



### BLOCK DIAGRAM

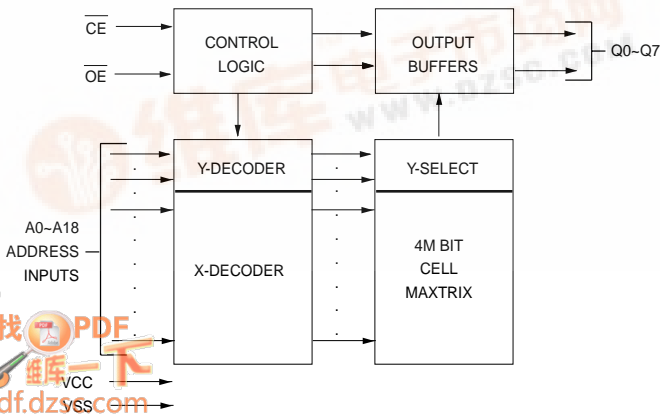

### PIN DESCRIPTION

SYMBOL	PIN NAME
A0~A18	Address Input
Q0~Q7	Data Input/Output
$\overline{CE}$	Chip Enable Input
$\overline{OE}$	Output Enable Input
VPP	Program Supply Voltage
VCC	Power Supply Pin (+5V)
GND	Ground Pin





## FUNCTIONAL DESCRIPTION

### THE PROGRAMMING OF THE MX27C4000

When the MX27C4000 is delivered, or it is erased, the chip has all 4M bits in the "ONE" or HIGH state. "ZEROS" are loaded into the MX27C4000 through the procedure of programming.

For programming, the data to be programmed is applied with 8 bits in parallel to the data pins.

Vcc must be applied simultaneously or before Vpp, and removed simultaneously or after Vpp. When programming an MXIC EPROM, a 01uF capacitor is required across Vpp and ground to suppress spurious voltage transients which may damage the device.

### FAST PROGRAMMING

The device is set up in the fast programming mode when the programming voltage  $V_{PP} = 12.75V$  is applied, with  $V_{CC} = 6.25V$  and  $\overline{OE} = V_{IH}$  (Algorithm is shown in Figure 1). The programming is achieved by applying a single TTL low level 100us pulse to the CE input after addresses and data line are stable. If the data is not verified, an additional pulse is applied for a maximum of 25 pulses. This process is repeated while sequencing through each address of the device. When the programming mode is completed, the data in all address is verified at  $V_{CC} = V_{PP} = 5V \pm 10\%$ .

### PROGRAM INHIBIT MODE

Programming of multiple MX27C4000s in parallel with different data is also easily accomplished by using the Program Inhibit Mode. Except for CE and OE, all like inputs of the parallel MX27C4000 may be common. A TTL low-level program pulse applied to an MX27C4000 CE input with  $V_{PP} = 12.5 \pm 0.5V$  and CE LOW will program that MX27C4000. A high-level CE input inhibits the other MX27C4000s from being programmed.

### PROGRAM VERIFY MODE

Verification should be performed on the programmed bits to determine that they were correctly programmed. The verification should be performed with OE and CE at VIL, and VPP at its programming voltage.

## AUTO IDENTIFY MODE

The auto identify mode allows the reading out of a binary code from an EPROM that will identify its manufacturer and device type. This mode is intended for use by programming equipment for the purpose of automatically matching the device to be programmed with its corresponding programming algorithm. This mode is functional in the  $25^{\circ}C \pm 5^{\circ}C$  ambient temperature range that is required when programming the MX27C4000.

To activate this mode, the programming equipment must force  $12.0 \pm 0.5V$  on address line A9 of the device. Two identifier bytes may then be sequenced from the device outputs by toggling address line A0 from VIL to VIH. All other address lines must be held at VIL during auto identify mode.

Byte 0 (A0 = VIL) represents the manufacturer code, and byte 1 (A0 = VIH), the device identifier code. For the MX27C4000, these two identifier bytes are given in the Mode Select Table. All identifiers for manufacturer and device codes will possess odd parity, with the MSB (Q7) defined as the parity bit.

## READ MODE

The MX27C4000 has two control functions, both of which must be logically satisfied in order to obtain data at the outputs. Chip Enable ( $\overline{CE}$ ) is the power control and should be used for device selection. Output Enable ( $\overline{OE}$ ) is the output control and should be used to gate data to the output pins, independent of device selection. Assuming that addresses are stable, address access time ( $t_{ACC}$ ) is equal to the delay from  $\overline{CE}$  to output ( $t_{CE}$ ). Data is available at the outputs  $t_{OE}$  after the falling edge of  $\overline{OE}$ 's, assuming that  $\overline{CE}$  has been LOW and addresses have been stable for at least  $t_{ACC} - t_{OE}$ .

## STANDBY MODE

The MX27C4000 has a CMOS standby mode which reduces the maximum VCC current to 100 uA. It is placed in CMOS standby when  $\overline{CE}$  is at  $V_{CC} \pm 0.3V$ . The MX27C4000 also has a TTL-standby mode which reduces the maximum VCC current to 1.5 mA. It is placed in TTL-standby when  $\overline{CE}$  is at VIH. When in standby mode, the outputs are in a high-impedance state, independent of the OE input.



## TWO-LINE OUTPUT CONTROL FUNCTION

To accommodate multiple memory connections, a two-line control function is provided to allow for:

1. Low memory power dissipation,
2. Assurance that output bus contention will not occur.

It is recommended that  $\overline{CE}$  be decoded and used as the primary device-selecting function, while  $\overline{OE}$  be made a common connection to all devices in the array and connected to the READ line from the system control bus. This assures that all deselected memory devices are in their low-power standby mode and that the output pins are only active when data is desired from a particular memory device.

## SYSTEM CONSIDERATIONS

During the switch between active and standby conditions, transient current peaks are produced on the rising and falling edges of Chip Enable. The magnitude of these transient current peaks is dependent on the output capacitance loading of the device. At a minimum, a 0.1 uF ceramic capacitor (high frequency, low inherent inductance) should be used on each device between VCC and GND to minimize transient effects. In addition, to overcome the voltage drop caused by the inductive effects of the printed circuit board traces on EPROM arrays, a 4.7 uF bulk electrolytic capacitor should be used between VCC and GND for each eight devices. The location of the capacitor should be close to where the power supply is connected to the array.

## MODE SELECT TABLE

MODE	PINS					
	$\overline{CE}$	$\overline{OE}$	A0	A9	VPP	OUTPUTS
Read	VIL	VIL	X	X	VCC	DOUT
Output Disable	VIL	VIH	X	X	VCC	High Z
Standby (TTL)	VIH	X	X	X	VCC	High Z
Standby (CMOS)	VCC±0.3V	X	X	X	VCC	High Z
Program	VIL	VIH	X	X	VPP	DIN
Program Verify	VIH	VIL	X	X	VPP	DOUT
Program Inhibit	VIH	VIH	X	X	VPP	High Z
Manufacturer Code(3)	VIL	VIL	VIL	VH	VCC	C2H
Device Code(3)	VIL	VIL	VIH	VH	VCC	40H

- NOTES:**
1. VH = 12.0 V ± 0.5 V
  2. X = Either VIH or VIL

3. A1 - A8 = A10 - A18 = VIL(For auto select)
4. See DC Programming Characteristics for VPP voltage during programming.

FIGURE 1. FAST PROGRAMMING FLOW CHART

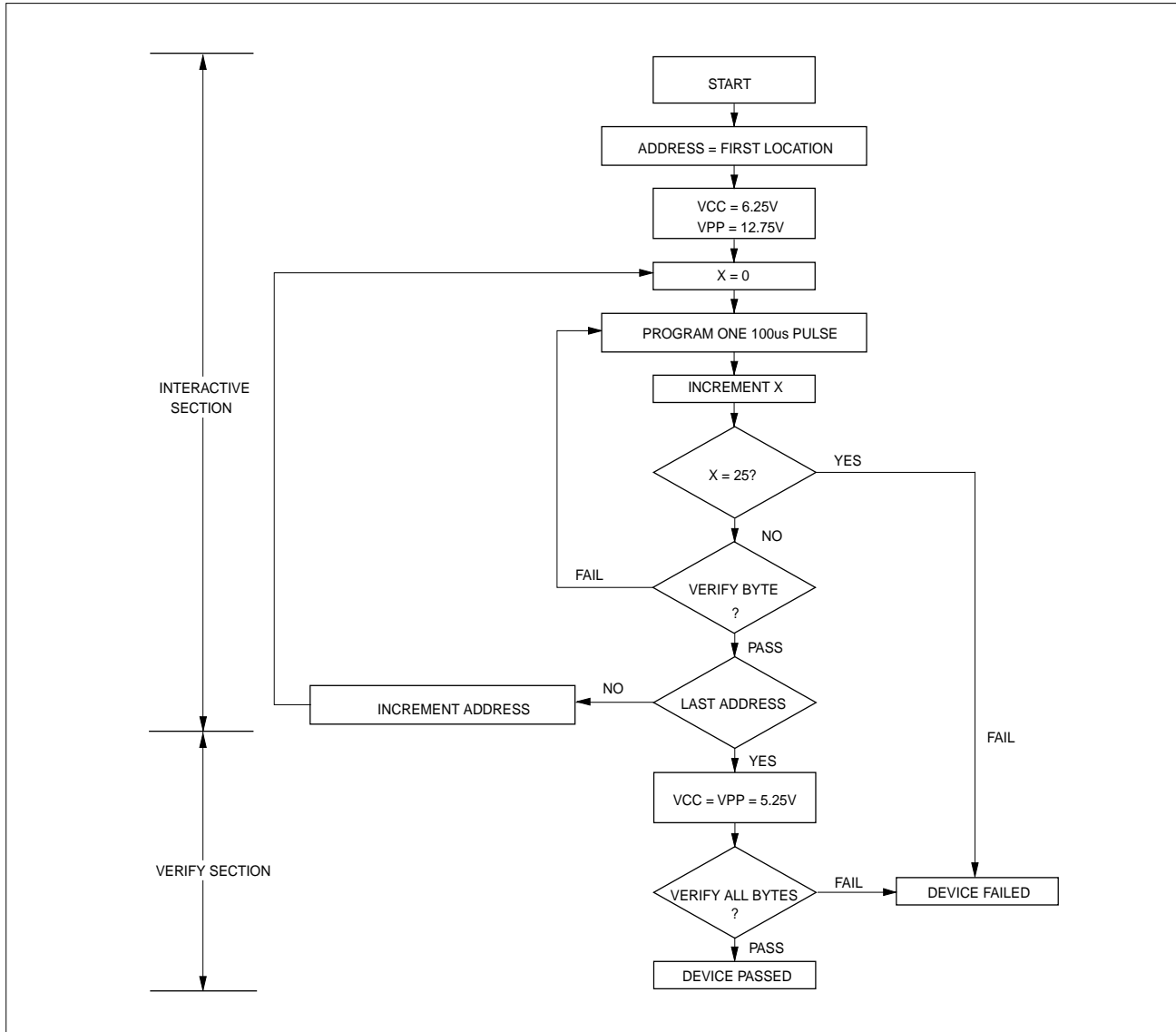

## SWITCHING TEST CIRCUITS

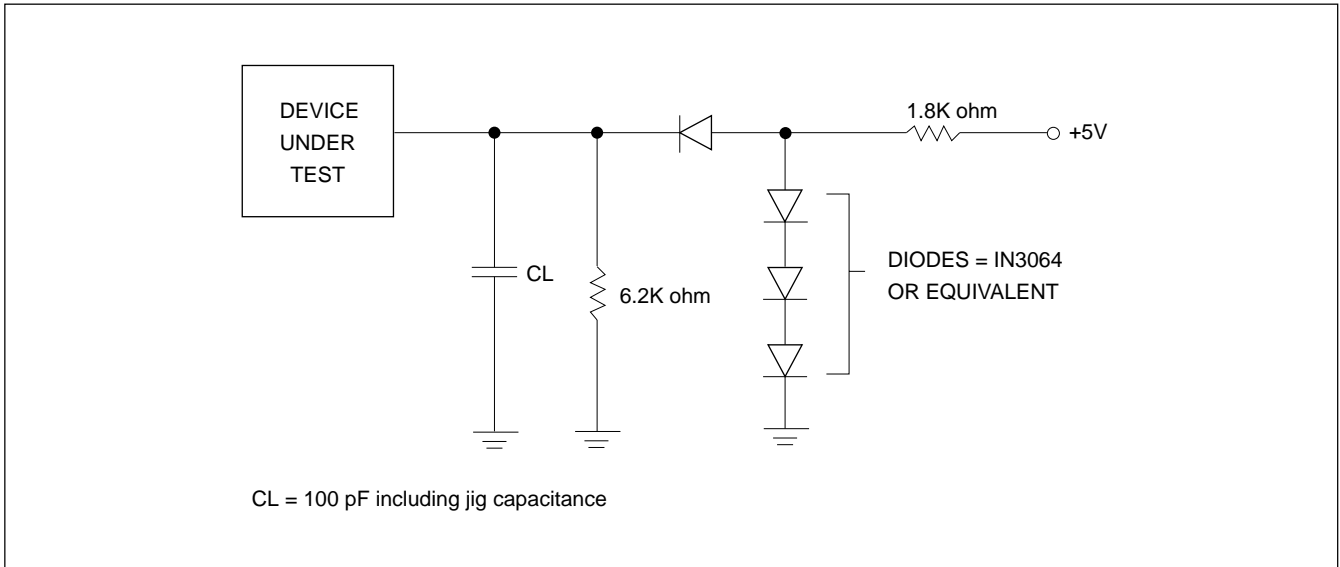

## SWITCHING TEST WAVEFORMS

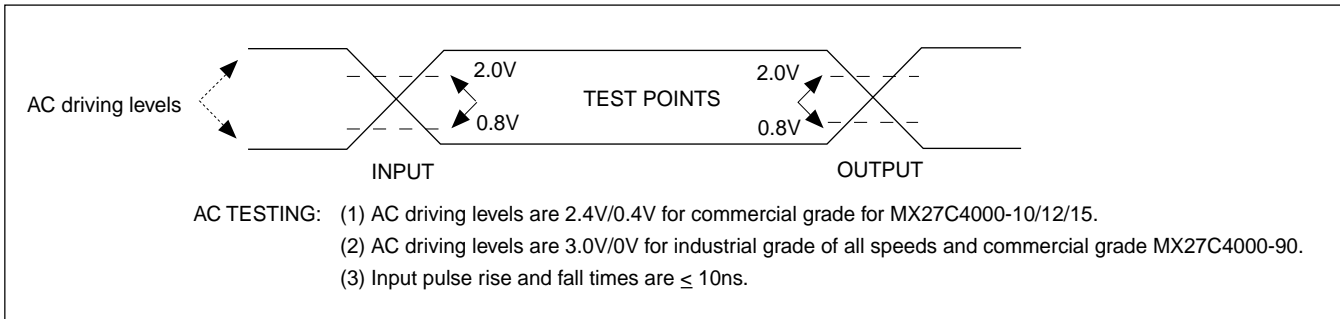



# MX27C4000

## ABSOLUTE MAXIMUM RATINGS

RATING	VALUE
Ambient Operating Temperature	-40°C to 85°C
Storage Temperature	-65°C to 125°C
Applied Input Voltage	-0.5V to 7.0V
Applied Output Voltage	-0.5V to VCC + 0.5V
VCC to Ground Potential	-0.5V to 7.0V
V9 & VPP	-0.5V to 13.5V

### NOTICE:

Stresses greater than those listed under ABSOLUTE MAXIMUM RATINGS may cause permanent damage to the device. This is a stress rating only and functional operation of the device at these or any other conditions above those indicated in the operational sections of this specification is not implied. Exposure to absolute maximum rating conditions for extended period may affect reliability.

### NOTICE:

Specifications contained within the following tables are subject to change.

## DC/AC Operating Conditions for Read Operation

		MX27C4000			
		-90	-10	-12	-15
Operating Temperature	Commercial	0°C to 70°C	0°C to 70°C	0°C to 70°C	0°C to 70°C
	Industrial			-40°C to 85°C	-40°C to 85°C
Vcc Power Supply		5V ± 10%	5V ± 10%	5V ± 10%	5V ± 10%

## DC CHARACTERISTICS

SYMBOL	PARAMETER	MIN.	MAX.	UNIT	CONDITIONS
VOH	Output High Voltage	2.4		V	IOH = -0.4mA
VOL	Output Low Voltage		0.4	V	IOL = 2.1mA
VIH	Input High Voltage	2.0	VCC + 0.5	V	
VIL	Input Low Voltage	-0.3	0.8	V	
ILI	Input Leakage Current	-10	10	uA	VIN = 0 to 5.5V
ILO	Output Leakage Current	-10	10	uA	VOUT = 0 to 5.5V
ICC3	VCC Power-Down Current		100	uA	$\overline{CE} = VCC \pm 0.3V$
ICC2	VCC Standby Current		1.5	mA	$\overline{CE} = VIH$
ICC1	VCC Active Current		40	mA	$\overline{CE} = VIL, f=5MHz, Iout = 0mA$
IPP	VPP Supply Current Read		10	uA	$\overline{CE} = \overline{OE} = VIL, VPP = 5.5V$

## CAPACITANCE

SYMBOL	PARAMETER	TYP.	MAX.	UNIT	CONDITIONS
CIN	Input Capacitance	8	12	pF	VIN = 0V
COUT	Output Capacitance	8	12	pF	VOUT = 0V
CVPP	VPP Capacitance	18	25	pF	VPP = 0V



## AC CHARACTERISTICS

SYMBOL	PARAMETER	27C4000-90		27C4000-10		27C4000-12		27C4000-15		UNIT	CONDITIONS
		MIN.	MAX.	MIN.	MAX.	MIN.	MAX.	MIN.	MAX.		
tACC	Address to Output Delay		90		100		120		150	ns	$\overline{CE} = \overline{OE} = VIL$
tCE	Chip Enable to Output Delay		90		100		120		150	ns	$\overline{OE} = VIL$
tOE	Output Enable to Output Delay		40		45		50		65	ns	$\overline{CE} = VIL$
tDF	$\overline{OE}$ High to Output Float, or $\overline{CE}$ High to Output Float	0	25	0	30	0	35	0	50	ns	
tOH	Output Hold from Address, $\overline{CE}$ or $\overline{OE}$ which ever occurred first	0		0		0		0		ns	

## DC PROGRAMMING CHARACTERISTICS TA = 25°C ± 5°C

SYMBOL	PARAMETER	MIN.	MAX.	UNIT	CONDITIONS
VOH	Output High Voltage	2.4		V	IOH = -0.40mA
VOL	Output Low Voltage		0.4	V	IOL = 2.1mA
VIH	Input High Voltage	2.0	VCC + 0.5	V	
VIL	Input Low Voltage	-0.3	0.8	V	
ILI	Input Leakage Current	-10	10	uA	VIN = 0 to 5.5V
VH	A9 Auto Select Voltage	11.5	12.5	V	
ICC3	VCC Supply Current (Program & Verify)		50	mA	
IPP2	VPP Supply Current(Program)		30	mA	$\overline{CE} = VIL, \overline{OE} = VIH$
VCC1	Fast Programming Supply Voltage	6.00	6.50	V	
VPP1	Fast Programming Voltage	12.5	13.0	V	

## AC PROGRAMMING CHARACTERISTICS TA = 25°C ± 5°C

SYMBOL	PARAMETER	MIN.	MAX.	UNIT	CONDITIONS
tAS	Address Setup Time	2.0		us	
tOES	$\overline{OE}$ Setup Time	2.0		us	
tDS	Data Setup Time	2.0		us	
tAH	Address Hold Time	0		us	
tDH	Data Hold Time	2.0		us	
tDFP	Out put Enable to Output Float Delay	0	130	ns	
tVPS	VPP Setup Time	2.0		us	
tPW	$\overline{PGM}$ Program Pulse Width	95	105	us	
tVCS	VCC Setup Time	2.0		us	
tOE	Data valid from $\overline{OE}$		150	ns	

## WAVEFORMS READ CYCLE

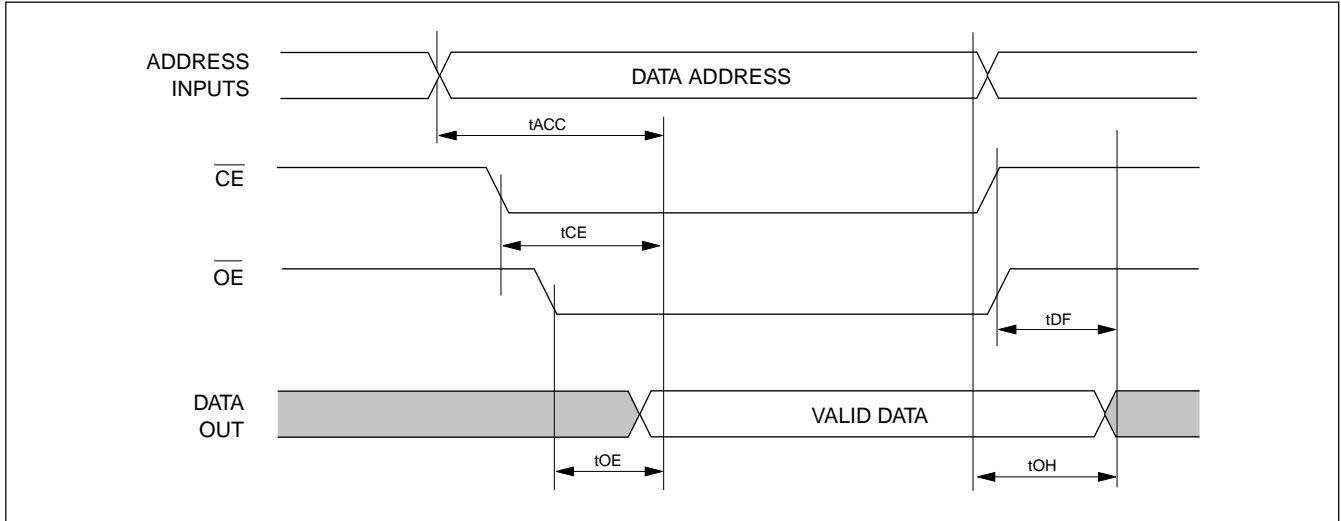

## FAST PROGRAMMING ALGORITHM WAVEFORM

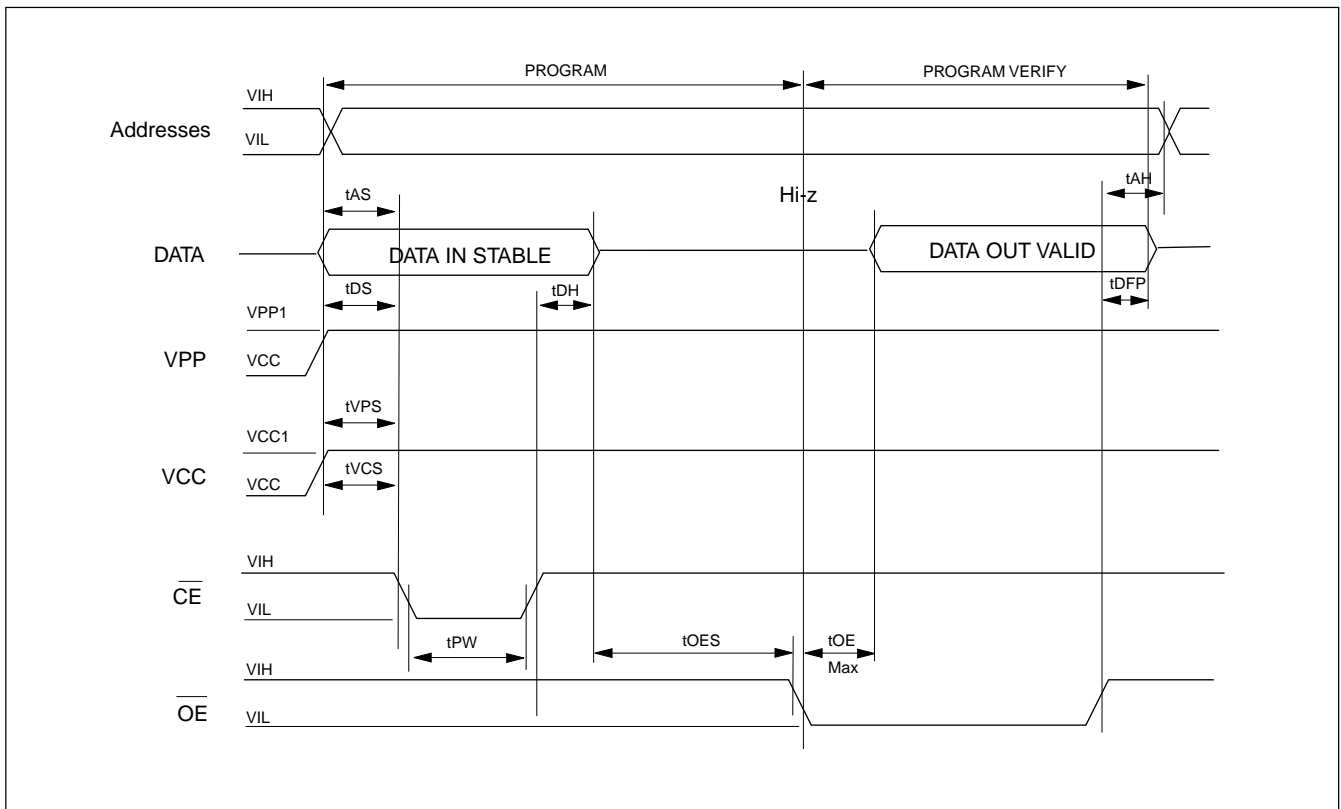





# MX27C4000

## ORDERING INFORMATION

### PLASTIC PACKAGE

PART NO.	ACCESS TIME(ns)	OPERATING CURRENT MAX.(mA)	STANDBY CURRENT MAX.(uA)	OPERATING TEMPERATURE	PACKAGE
MX27C4000PC-90	90	40	100	0°C to 70°C	32 Pin DIP
MX27C4000QC-90	90	40	100	0°C to 70°C	32 Pin PLCC
MX27C4000MC-90	90	40	100	0°C to 70°C	32 Pin SOP
MX27C4000PC-100	100	40	100	0°C to 70°C	32 Pin DIP
MX27C4000QC-100	100	40	100	0°C to 70°C	32 Pin PLCC
MX27C4000MC-100	100	40	100	0°C to 70°C	32 Pin SOP
MX27C4000PC-120	120	40	100	0°C to 70°C	32 Pin DIP
MX27C4000QC-120	120	40	100	0°C to 70°C	32 Pin PLCC
MX27C4000MC-120	120	40	100	0°C to 70°C	32 Pin SOP
MX27C4000TC-120	120	40	100	0°C to 70°C	32 Pin TSOP
MX27C4000PC-150	150	40	100	0°C to 70°C	32 Pin DIP
MX27C4000QC-150	150	40	100	0°C to 70°C	32 Pin PLCC
MX27C4000MC-150	150	40	100	0°C to 70°C	32 Pin SOP
MX27C4000TC-150	150	40	100	0°C to 70°C	32 Pin TSOP
MX27C4000PI-120	120	40	100	-40°C to 85°C	32 Pin DIP
MX27C4000QI-120	120	40	100	-40°C to 85°C	32 Pin PLCC
MX27C4000MI-120	120	40	100	-40°C to 85°C	32 Pin SOP
MX27C4000TI-120	120	40	100	-40°C to 85°C	32 Pin TSOP
MX27C4000PI-150	150	40	100	-40°C to 85°C	32 Pin DIP
MX27C4000QI-150	150	40	100	-40°C to 85°C	32 Pin PLCC
MX27C4000MI-150	150	40	100	-40°C to 85°C	32 Pin SOP
MX27C4000TI-150	150	40	100	-40°C to 85°C	32 Pin TSOP



# MX27C4000

## PACKAGE INFORMATION

32-PIN PLASTIC DIP(600 mil)

UNIT SYMBOL	INCH(BASE)	MM(REF.)
A	0.155±0.008	3.937±0.203
A1	0.025±0.005	0.635±0.127
B	0.018 (REF.)	0.457 (REF.)
B1	0.050 (REF.)	1.270 (REF.)
C	0.010 (REF.)	0.254 (REF.)
D	1.65±0.005	41.91±0.127
E	0.600±0.005	15.240±0.127
E1	0.550±0.005	13.970±0.127
e1	0.100(REF.)	2.540 (REF.)
eA	0.650±0.030	16.510±0.762
L	0.13	3.30
Q1	0.0725±0.005	1.8415±0.127
S	0.075±0.005	1.905±0.127

<b>Mxic</b> 旺宏電子股份有限公司 Macronix International Co., Ltd.		DWG. NO. 6110-0202.2	
TITLE PACKAGE OUTLINE FOR PDP 32L (600 MIL)		TOLERANCE X ±. XX ±.01 XXX±.002	
DRAWN C.L.Chiang	APPROVED Leo Lee	DATE 05-02-01	REVISION 4

## 32-PIN PLASTIC SOP (450 mil)

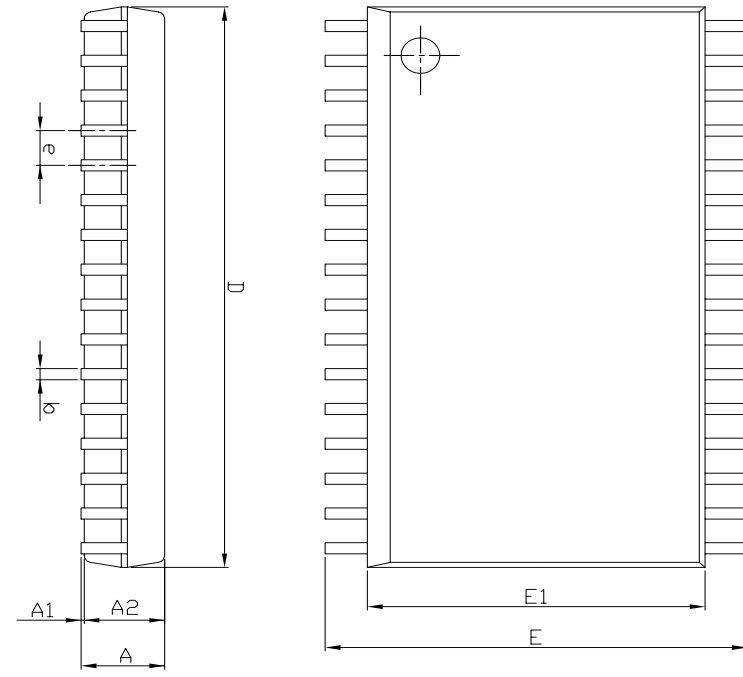

Symbol	Dimension in mm (Base)			Dimension in inch (Ref.)		
	Min	Nom	Max	Min	Nom	Max
A	—	—	3.00	—	—	0.118
A1	0.10	—	—	0.004	—	—
A2	2.57	2.69	2.82	0.101	0.106	0.111
b	0.41 REF			0.016 REF		
c	0.20 REF			0.008 REF		
D	20.32	20.45	20.57	0.800	0.805	0.810
E	13.87	14.12	14.38	0.546	0.556	0.566
E1	11.18	11.30	11.43	0.440	0.445	0.450
e	1.27 REF			0.050 REF		
L	0.58	0.79	0.99	0.023	0.031	0.039
phi	—	5°	—	—	5°	—

JEDEC

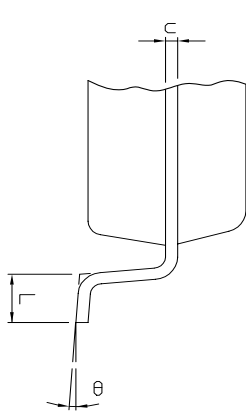

<b>Mxic</b> 旺宏電子股份有限公司 Macronix International Co., Ltd.		DWG. NO. 61110-0206	
TITLE PACKAGE OUTLINE FOR SOP 32L (450 MIL)		TOLERANCE X ±. XX ±.01 .XXX±.002	
DRAWN C.L.Chiang	APPROVED Dennis Chang	DATE 05-03-01	UNIT INCH
REVISION 2		ROUGHNESS	

## 32-PIN PLASTIC LEADED CHIP CARRIER (PLCC)

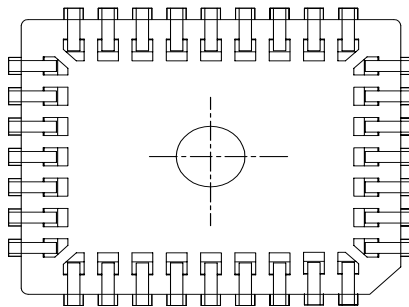
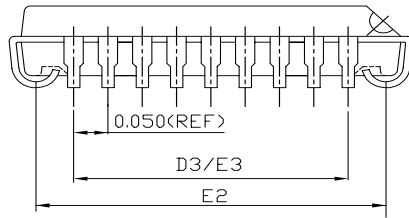
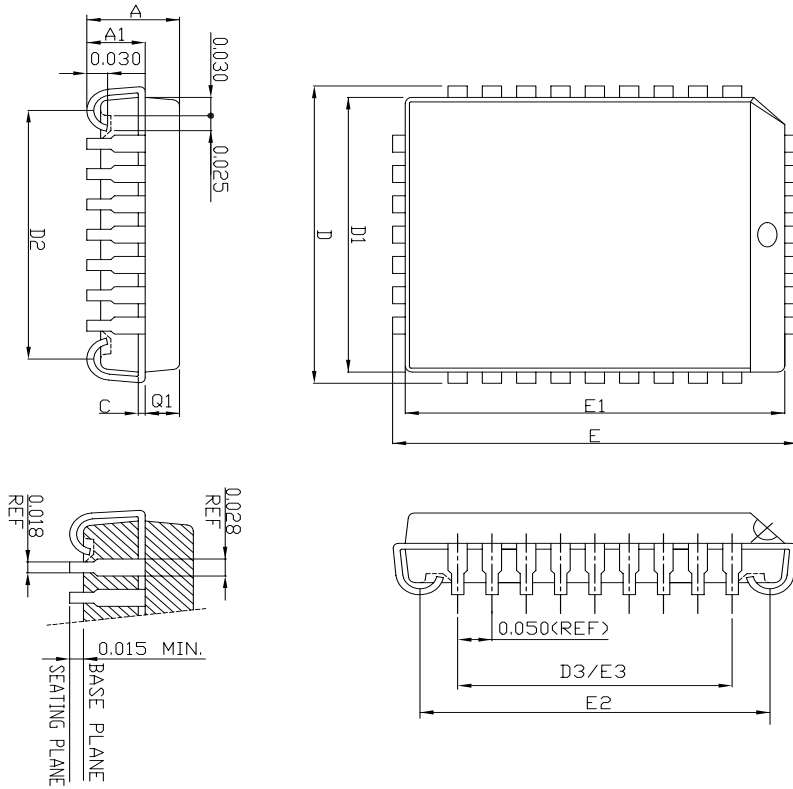

Symbol	Dimension in inch (Ref.)			Dimension in mm (Base)		
	Min	Nom	Max	Min	Nom	Max
A			0.140			3.56
A1	0.080	0.085	0.090	2.03	2.16	2.29
Q1	0.048	0.050	0.052	1.22	1.27	1.32
C	0.010(REF)			0.25(REF)		
D	0.485	0.490	0.495	12.32	12.45	12.57
D1	0.450	0.453	0.456	11.43	11.51	11.58
D2	0.400	0.410	0.420	10.16	10.41	10.67
D3	0.300(REF)			7.62(REF)		
E	0.585	0.590	0.595	14.86	14.99	15.11
E1	0.550	0.553	0.556	13.97	14.05	14.12
E2	0.500	0.510	0.520	12.70	12.95	13.21
E3	0.400(REF)			10.16(REF)		

REFERENCE DOCUMENT : JEDEC SPEC - MS-016a

<b>MXIC</b> 旺宏電子股份有限公司		DWG. NO.	
Macronix International Co., Ltd.		6110-0209.1	
TITLE			
PACKAGE OUTLINE FOR		TOLERANCE	
PLCC 32L		.X ±	
		.XX ±01	
		.XXX±.002	
		ANGLE ±2°	
DRAWN		APPROVED	DATE
C.L. Chiang	Dennis Chang	05-03-01	inch
UNIT		REVISION	
2		2	

## 32-PIN PLASTIC TSOP

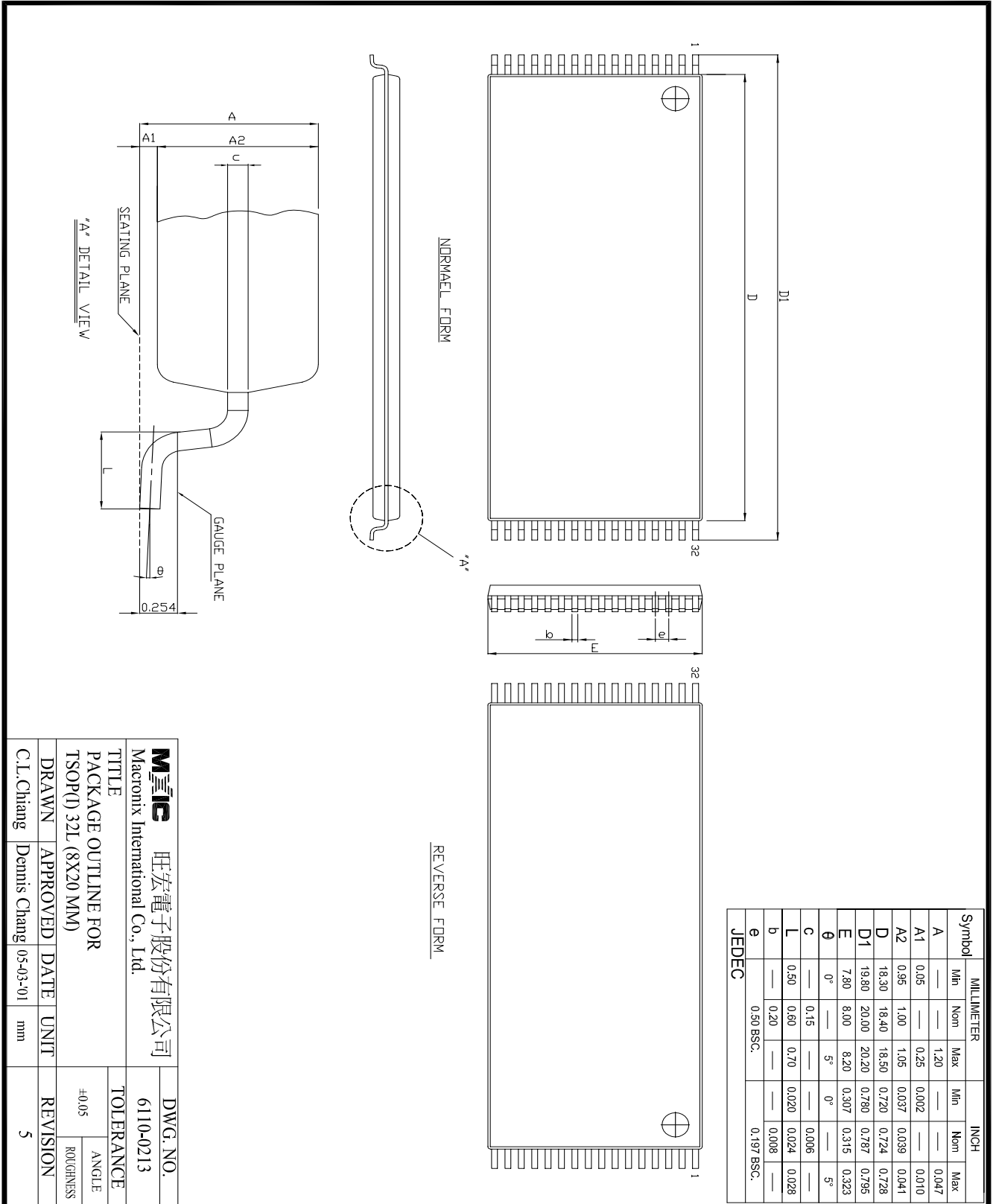

<b>Mxic</b> 旺宏電子股份有限公司 Macronix International Co., Ltd.		DWG. NO. 6110-0213	
TITLE PACKAGE OUTLINE FOR TSOP(I) 32L (8X20 MM)		TOLERANCE ±0.05	
DRAWN	APPROVED	DATE	UNIT
C.L.Chiang	Dennis Chang	05-03-01	mm
REVISION		5	



**REVISION HISTORY**

<b>Revision No.</b>	<b>Description</b>	<b>Page</b>	<b>Date</b>
3.0	1) Eliminate Interactive Programming Mode. 2) MX27C4000-90 AC driving levels changed from 2.4V/0.4V to 3.0V/0V.		5/29/1997
3.1	IPP1 100uA -----> 10uA		7/17/1997
3.2	Change TSOP Orientation.		4/09/1998
3.3	Cancel ceramic DIP package type	P1,2,9,10	MAR/01/2000
3.4	Cancel "Ultraviolet Erasable" wording in General Description To modify Package Information	P1 P10~13	AUG/20/2001



**MX27C4000**

---

---

**MACRONIX INTERNATIONAL Co., LTD.**

**HEADQUARTERS:**

TEL:+886-3-578-6688

FAX:+886-3-563-2888

**EUROPE OFFICE:**

TEL:+32-2-456-8020

FAX:+32-2-456-8021

**JAPAN OFFICE:**

TEL:+81-44-246-9100

FAX:+81-44-246-9105

**SINGAPORE OFFICE:**

TEL:+65-348-8385

FAX:+65-348-8096

**TAIPEI OFFICE:**

TEL:+886-2-2509-3300

FAX:+886-2-2509-2200

**MACRONIX AMERICA, INC.**

TEL:+1-408-453-8088

FAX:+1-408-453-8488

**CHICAGO OFFICE:**

TEL:+1-847-963-1900

FAX:+1-847-963-1909

**[http : //www.macronix.com](http://www.macronix.com)**

---