

TOSHIBA CMOS DIGITAL INTEGRATED CIRCUIT SILICON MONOLITHIC

# TC7S32F, TC7S32FU

## 2-INPUT OR GATE

The TC7S32 is a high speed C<sup>2</sup>MOS 2-INPUT OR GATE fabricated with silicon gate C<sup>2</sup>MOS technology. It achieves high speed operation similar to equivalent LSTTL while maintaining the C<sup>2</sup>MOS low power dissipation.

The internal circuit is composed of 2 stages including buffer output, which enables high noise immunity and stable output.

All inputs are equipped with protection circuits against static discharge or transient excess voltage.

Output currents are 1/2 compared to TC74HC series models.

### FEATURES

- High Speed .....  $t_{pd} = 7ns$  (Typ.) at  $V_{CC} = 5V$
- Low Power Dissipation .....  $I_{CC} = 1\mu A$  (Max.) at  $T_a = 25^\circ C$
- High Noise Immunity .....  $V_{NIH} = V_{NIL} = 28\% V_{CC}$  (Min.)
- Output Drive Capability ..... 5 LSTTL Loads
- Symmetrical Output Impedance ...  $|I_{OH}| = I_{OL} = 2mA$  (Min.)
- Balanced Propagation Delays .....  $t_{pLH} \cong t_{pHL}$
- Wide Operating Voltage Range ...  $V_{CC} (opr) = 2\sim 6V$

### MAXIMUM RATINGS

CHARACTERISTIC	SYMBOL	RATING	UNIT
Supply Voltage Range	$V_{CC}$	-0.5~7	V
DC Input Voltage	$V_{IN}$	-0.5~ $V_{CC} + 0.5$	V
DC Output Voltage	$V_{OUT}$	-0.5~ $V_{CC} + 0.5$	V
Input Diode Current	$I_{IK}$	$\pm 20$	mA
Output Diode Current	$I_{OK}$	$\pm 20$	mA
DC Output Current	$I_{OUT}$	$\pm 12.5$	mA
DC $V_{CC}$ / Ground Current	$I_{CC}$	$\pm 25$	mA
Power Dissipation	$P_D$	200	mW
Storage Temperature	$T_{stg}$	-65~150	°C
Lead Temperature (10s)	$T_L$	260	°C

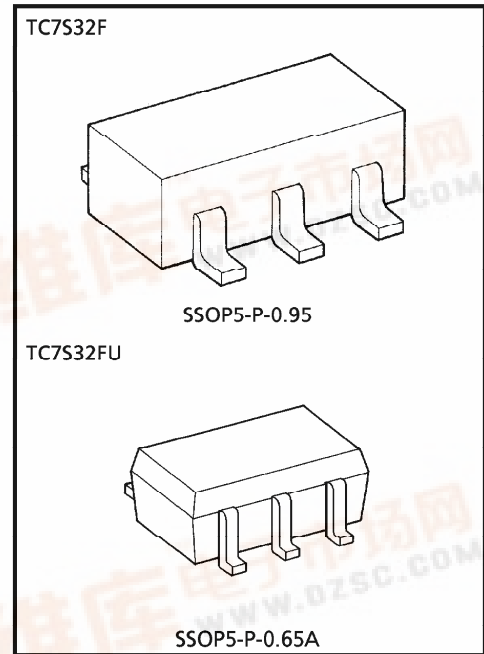

Weight SSOP5-P-0.95 : 0.016g (Typ.)  
SSOP5-P-0.65A : 0.006g (Typ.)

### MARKING

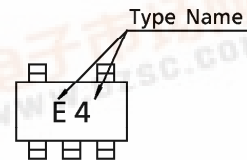

### PIN ASSIGNMENT (TOP VIEW)

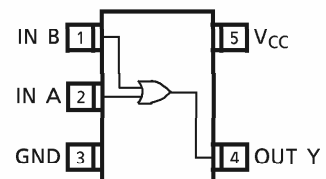

961001EBA2

● TOSHIBA is continually working to improve the quality and the reliability of its products. Nevertheless, semiconductor devices in general can malfunction or fail due to their inherent electrical sensitivity and vulnerability to physical stress. It is the responsibility of the buyer, when utilizing TOSHIBA products, to observe standards of safety, and to avoid situations in which a malfunction or failure of a TOSHIBA product could cause loss of human life, bodily injury or damage to property. In developing your designs, please ensure that TOSHIBA products are used within specified operating ranges as set forth in the most recent products specifications. Also, please keep in mind the precautions and conditions set forth in the TOSHIBA Semiconductor Reliability Handbook.

### LOGIC DIAGRAM

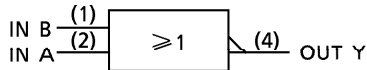

### RECOMMENDED OPERATING CONDITIONS

CHARACTERISTIC	SYMBOL	RATING	UNIT
Supply Voltage	V <sub>CC</sub>	2~6	V
Input Voltage	V <sub>IN</sub>	0~V <sub>CC</sub>	V
Output Voltage	V <sub>OUT</sub>	0~V <sub>CC</sub>	V
Operating Temperature	T <sub>opr</sub>	-40~85	°C
Input Rise and Fall Time	t <sub>r</sub> , t <sub>f</sub>	0~1000 (V <sub>CC</sub> = 2.0V) 0~500 (V <sub>CC</sub> = 4.5V) 0~400 (V <sub>CC</sub> = 6.0V)	ns

### DC ELECTRICAL CHARACTERISTICS

CHARACTERISTIC	SYMBOL	TEST CONDITION	Ta = 25°C				Ta = -40~85°C		UNIT	
			V <sub>CC</sub>	MIN.	TYP.	MAX.	MIN.	MAX.		
High-Level Input Voltage	V <sub>IH</sub>	—	2.0	1.5	—	—	1.5	—	V	
			4.5	3.15	—	—	3.15	—		
			6.0	4.2	—	—	4.2	—		
Low-Level Input Voltage	V <sub>IL</sub>	—	2.0	—	—	0.5	—	0.5	V	
			4.5	—	—	1.35	—	1.35		
			6.0	—	—	1.8	—	1.8		
High-Level Output Voltage	V <sub>OH</sub>	V <sub>IN</sub> = V <sub>IH</sub> or V <sub>IL</sub>	I <sub>OH</sub> = -20μA	2.0	1.9	2.0	—	1.9	—	V
				4.5	4.4	4.5	—	4.4	—	
				6.0	5.9	6.0	—	5.9	—	
Low-Level Output Voltage	V <sub>OL</sub>	V <sub>IN</sub> = V <sub>IL</sub>	I <sub>OL</sub> = 20μA	2.0	—	0.0	0.1	—	0.1	V
				4.5	—	0.0	0.1	—	0.1	
				6.0	—	0.0	0.1	—	0.1	
Input Leakage Current	I <sub>IN</sub>	V <sub>IN</sub> = V <sub>CC</sub> or GND	I <sub>OL</sub> = 2mA I <sub>OL</sub> = 2.6mA	4.5	4.18	4.31	—	4.13	—	μA
				6.0	5.68	5.80	—	5.63	—	
				6.0	—	0.17	0.26	—	0.33	
Quiescent Supply Current	I <sub>CC</sub>	V <sub>IN</sub> = V <sub>CC</sub> or GND	I <sub>OL</sub> = 2.6mA	6.0	—	0.18	0.26	—	0.33	μA
				6.0	—	—	±0.1	—	±1.0	
				6.0	—	—	1.0	—	10.0	

Output currents are 1/2 compared to TC74HC series models.

**AC ELECTRICAL CHARACTERISTICS** ( $C_L = 15\text{pF}$ , Input  $t_r = t_f = 6\text{ns}$ ,  $V_{CC} = 5\text{V}$ )

CHARACTERISTIC	SYMBOL	TEST CONDITION	Ta = 25°C			UNIT
			MIN.	TYP.	MAX.	
Output Transition Time	$t_{TLH}$	—	—	5	10	ns
	$t_{THL}$					
Propagation Delay Time	$t_{pLH}$	—	—	7	15	ns
	$t_{pHL}$					

**AC ELECTRICAL CHARACTERISTICS** ( $C_L = 50\text{pF}$ , Input  $t_r = t_f = 6\text{ns}$ )

CHARACTERISTIC	SYMBOL	TEST CONDITION	$V_{CC}$	Ta = 25°C			Ta = -40~85°C		UNIT
				MIN.	TYP.	MAX.	MIN.	MAX.	
Output Transition Time	$t_{TLH}$	—	2.0	—	50	125	—	155	ns
	$t_{THL}$		4.5	—	14	25	—	31	
			6.0	—	12	21	—	26	
Propagation Delay Time	$t_{pLH}$	—	2.0	—	48	100	—	125	ns
	$t_{pHL}$		4.5	—	12	20	—	25	
			6.0	—	9	17	—	21	
Input Capacitance	$C_{IN}$	—	—	5	10	—	10	pF	
Power Dissipation Capacitance	$C_{pD}$	(Note 1)	—	10	—	—	—		

Note 1 :  $C_{pD}$  defined as the value of internal equivalent capacitance of IC which is calculated from the operating current consumption without load (refer to Test Circuit).

Average operating current can be obtained by the equation hereunder.

$$I_{CC(opr)} = C_{pD} \cdot V_{CC} \cdot f_{IN} + I_{CC}$$

**SWITCHING CHARACTERISTICS TEST CIRCUIT**

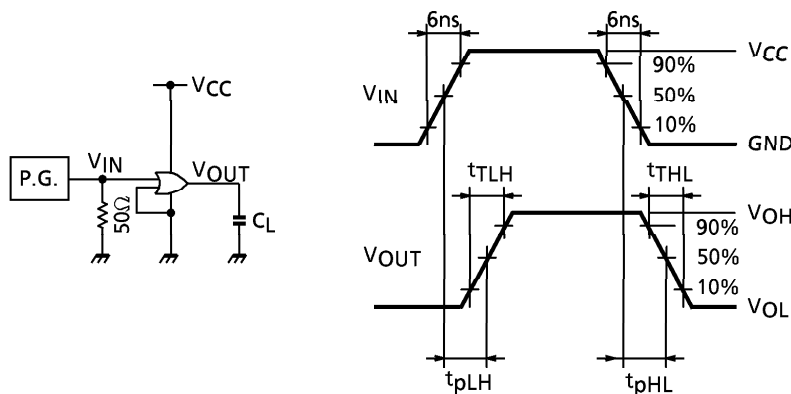

**$I_{CC(opr)}$  TEST CIRCUIT**

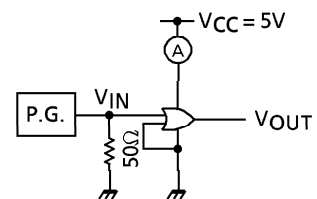

Input waveform is the same as that in case of switching characteristics test.

OUTLINE DRAWING  
SSOP5-P-0.95

Unit : mm

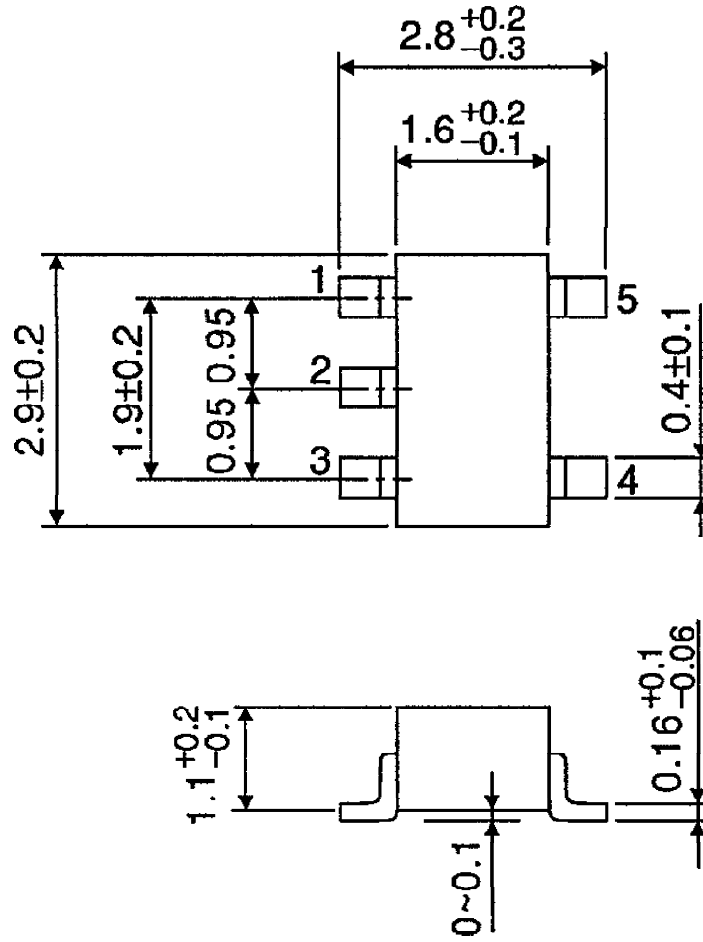

Weight : 0.016g (Typ.)

OUTLINE DRAWING  
SSOP5-P-0.65A

Unit : mm

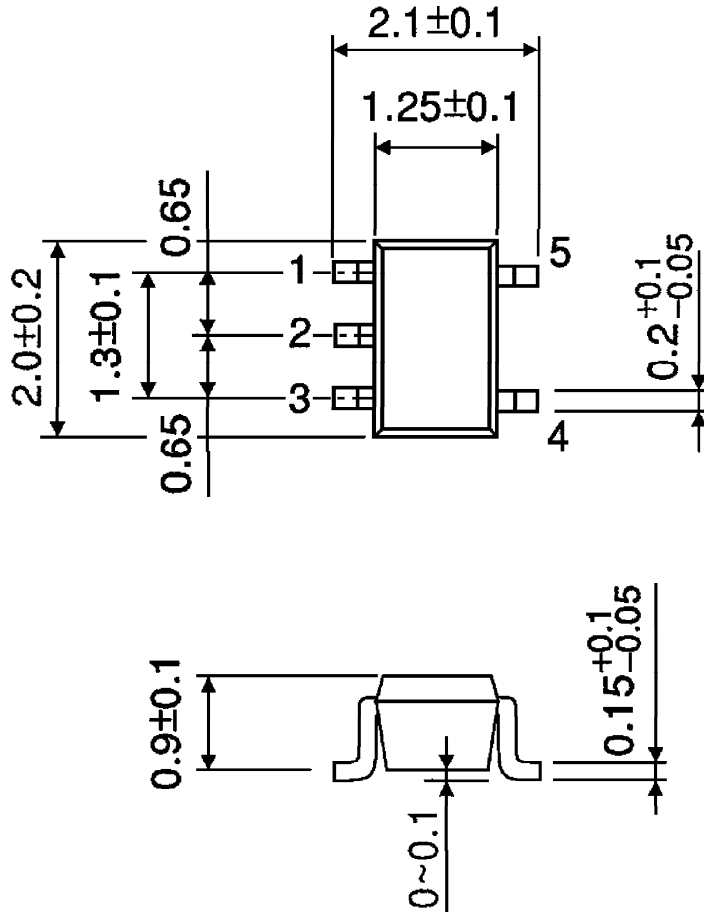

Weight : 0.006g (Typ.)