

TOSHIBA

TC7W53F/FU/FK

TC7W53FK : UNDER DEVELOPMENT

TOSHIBA CMOS DIGITAL INTEGRATED CIRCUIT SILICON MONOLITHIC

TC7W53F, TC7W53FU, TC7W53FK

2-CHANNEL MULTIPLEXER / DEMULTIPLEXER

The TC7W53 is a high speed CMOS ANALOG MULTIPLEXER/DEMULTIPLEXER fabricated with silicon gate CMOS technology. They achieve the high speed operation similar to equivalent LSTTL while maintaining the CMOS low power dissipation.

The TC7W53 has a 2 channel configuration. The digital signal to the control terminal turns "ON" the corresponding switch of each channel a large amplitude signal ($V_{CC}-V_{EE}$) can then be switched by the small logical amplitude ($V_{CC}-GND$) control signal. For example, in the case of $V_{CC} = 5V$, $GND = 0V$, $V_{EE} = 5V$, signals between $-5V$ and $+5V$ can be switched from the logical circuit with a single power supply of 5V. As the ON-resistance of each switch is low, they can be connected to circuit with low input impedance. All inputs are equipped with protection circuits against static discharge or transient excess voltage.

FEATURES

- High Speed $t_{pd} = 15ns$ (Typ.)
at $V_{CC} = 5V$, $V_{EE} = 0V$
- Low Power Dissipation $I_{CC} = 4\mu A$ (Max.) at $T_a = 25^\circ C$
- High Noise Immunity $V_{NIH} = V_{NIL} = 28\% V_{CC}$ (Min.)
- Low ON Resistance $R_{ON} = 50\Omega$ (Typ.)
at $V_{CC}-V_{EE} = 9V$
- High Degree of Linearity $THD = 0.02$ (Typ.)
at $V_{CC}-V_{EE} = 9V$
- Pin and Function Compatible with TC4W53

MARKING

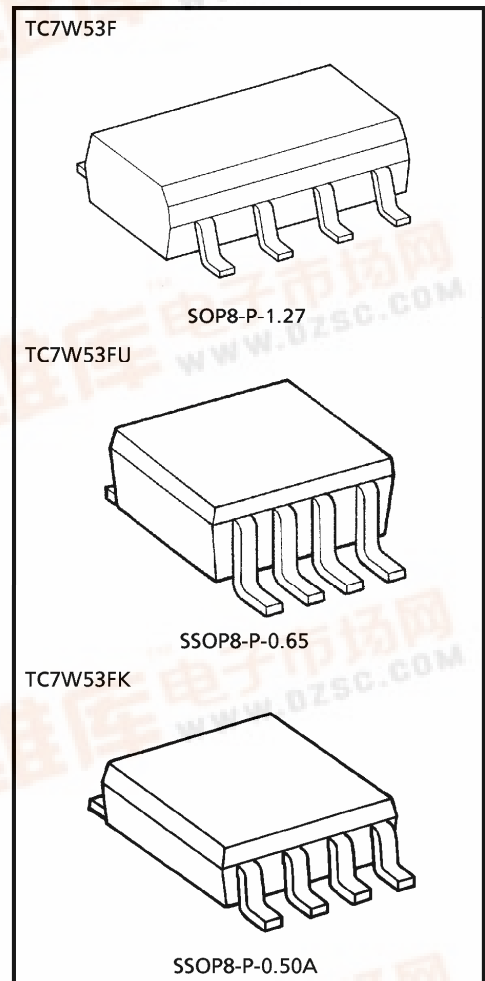
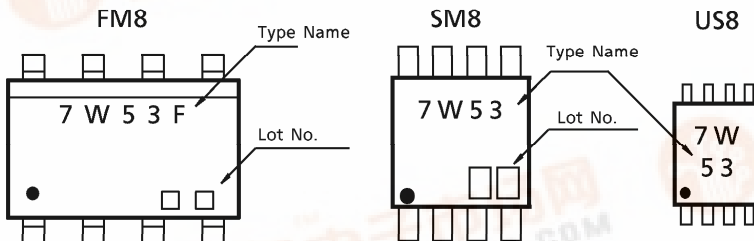

Weight

SOP8-P-1.27	: 0.05g (Typ.)
SSOP8-P-0.65	: 0.02g (Typ.)
SSOP8-P-0.50A	: 0.01g (Typ.)

980910EBA2

- TOSHIBA is continually working to improve the quality and the reliability of its products. Nevertheless, semiconductor devices in general can malfunction or fail due to their inherent electrical sensitivity and vulnerability to physical stress. It is the responsibility of the buyer, when utilizing TOSHIBA products, to observe standards of safety, and to avoid situations in which a malfunction or failure of a TOSHIBA product could cause loss of human life, bodily injury or damage to property. In developing your designs, please ensure that TOSHIBA products are used within specified operating ranges as set forth in the most recent products specifications. Also, please keep in mind the precautions and conditions set forth in the TOSHIBA Semiconductor Reliability Handbook.
- The products described in this document are subject to the foreign exchange and foreign trade laws.
- The information contained herein is presented only as a guide for the applications of our products. No responsibility is assumed by TOSHIBA CORPORATION for any infringements of intellectual property or other rights of the third parties which may result from its use. No license is granted by implication or otherwise under any intellectual property or other rights of TOSHIBA CORPORATION or others.
- The information contained herein is subject to change without notice.

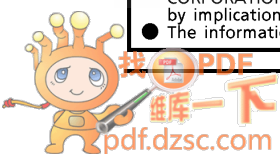

MAXIMUM RATINGS (Ta = 25°C)

CHARACTERISTIC	SYMBOL	RATING	UNIT
Supply Voltage Range	V _{CC}	-0.5~7	V
	V _{CC} ~V _{EE}	-0.5~13	
Control Input Voltage	V _{IN}	-0.5~V _{CC} + 0.5	V
Switch I/O Voltage	V _{I/O}	V _{EE} - 0.5~V _{CC} + 0.5	V
Control Input Diode Current	I _{CK}	± 20	mA
I/O Diode Current	I _{I/O}	± 20	mA
Switch Through Current	I _T	± 25	mA
DC V _{CC} /GND Current	I _{CC}	± 25	mA
Power Dissipation	P _D	300 (FM8, SM8)	mW
		200 (US8)	
Storage Temperature	T _{stg}	-65~150	°C
Lead Temperature (10 s)	T _L	260	°C

TRUTH TABLE

CONTROL INPUT		ON CHANNEL
INH	A	
L	L	ch 0
L	H	ch 1
H	x	NONE

x : Don't care

LOGIC SYMBOL

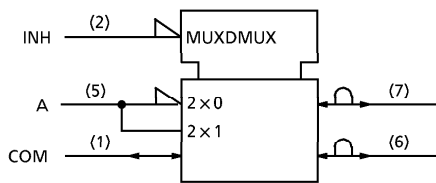

PIN ASSIGNMENT (TOP VIEW)

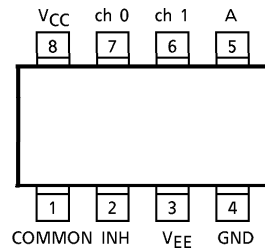

LOGIC DIAGRAM

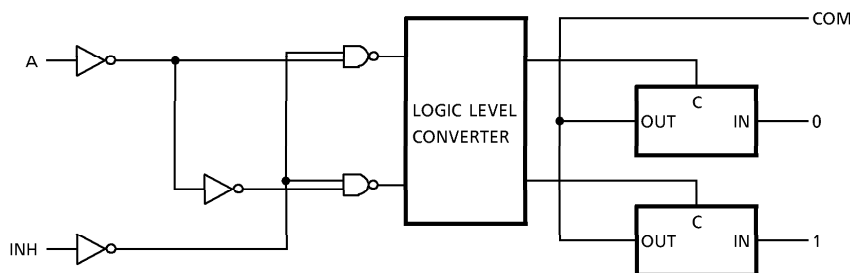

RECOMMENDED OPERATING CONDITIONS

CHARACTERISTIC	SYMBOL	RATING	UNIT
Supply Voltage	V _{CC}	2~12	V
	V _{EE}	-6~0	V
	V _{CC} ~V _{EE}	2~12	V
Control Input Voltage	V _{IN}	0~V _{CC}	V
Switch I/O Voltage	V _{I/O}	0~V _{CC}	V
Operating Temperature	T _{opr}	-40~85	°C
Input Rise and Fall Time	t _r , t _f	0~1000 (V _{CC} = 2.0V)	ns
		0~500 (V _{CC} = 4.5V)	
		0~400 (V _{CC} = 6.0V)	

DC ELECTRICAL CHARACTERISTICS

CHARACTERISTIC	SYMBOL		V _{EE} (V)	V _{CC} (V)	Ta = 25°C			Ta = -40~85°C		UNIT	
					MIN.	TYP.	MAX.	MIN.	MAX.		
High-Level Control Input Voltage	V _{IHC}			2.0	1.5	—	—	1.5	—	V	
				4.5	3.15	—	—	3.15	—		
				6.0	4.2	—	—	4.2	—		
Low-Level Control Input Voltage	V _{ILC}			2.0	—	—	0.5	—	0.5	V	
				4.5	—	—	1.35	—	1.35		
				6.0	—	—	1.8	—	1.8		
ON Resistance	R _{ON}	V _{IN} = V _{IHC}	GND	4.5	—	85	180	—	225	Ω	
		V _{I/O} = V _{CC} to GND		-4.5	4.5	—	55	120	—		150
		V _{I/O} ≤ 2mA		-6.0	6.0	—	50	100	—		125
		V _{IN} = V _{IHC}		GND	2.0	—	150	—	—		—
		V _{I/O} = V _{CC} or GND		GND	4.5	—	70	150	—		190
		V _{I/O} ≤ 2mA		-4.5	4.5	—	50	100	—		125
Difference of ON Resistance Between Switches	ΔR _{ON}	V _{IN} = V _{IHC}	GND	4.5	—	10	30	—	35	Ω	
		V _{I/O} = V _{CC} to GND		-4.5	4.5	—	5	12	—		15
		V _{I/O} ≤ 2mA		-6.0	6.0	—	5	10	—		12
Input / Output Leakage Current (SWITCH OFF)	I _{OFF}	V _{OS} = GND	GND	6.0	—	—	±60	—	±600	nA	
		V _{IS} = GND to V _{CC} V _{IN} = V _{ILC} or V _{IHC}		-6.0	6.0	—	—	±100	—		±1000
Switch Input Leakage Current (SWITCH ON OUTPUT OPEN)	I _{Iz}	V _{OS} = V _{CC} or GND	GND	6.0	—	—	±60	—	±600	nA	
		V _{IN} = V _{ILC} or V _{IHC}		-6.0	6.0	—	—	±100	—		±1000
Control Input Current	I _{IN}	V _{IN} = V _{CC} or GND	GND	6.0	—	—	±0.1	—	±1.0	μA	
Quiescent Supply Current	I _{CC}	V _{IN} = V _{CC} or GND	GND	6.0	—	—	4	—	40	μA	
			-6.0	6.0	—	—	8	—	80		

AC ELECTRICAL CHARACTERISTICS ($C_L = 50\text{pF}$, Input $t_r = t_f = 6\text{ns}$, GND = 0V)

CHARACTERISTIC		TEST CONDITION	V _{EE} (V)	V _{CC} (V)	Ta = 25°C			Ta = -40~85°C		UNIT
					MIN.	TYP.	MAX.	MIN.	MAX.	
Phase Difference Between Input and Output	$\phi_{I/O}$		GND	2.0	—	25	60	—	75	ns
			GND	4.5	—	6	12	—	15	
			GND	6.0	—	5	10	—	13	
			-4.5	4.5	—	4	—	—	—	
Output Enable Time	t_{pZL} t_{pZH}	$R_L = 1\text{k}\Omega$	GND	2.0	—	50	225	—	280	ns
			GND	4.5	—	14	45	—	56	
			GND	6.0	—	12	38	—	48	
			-4.5	4.5	—	14	—	—	—	
Output Disable Time	t_{pLZ} t_{pHZ}	$R_L = 1\text{k}\Omega$	GND	2.0	—	95	225	—	280	ns
			GND	4.5	—	30	45	—	56	
			GND	6.0	—	26	38	—	48	
			-4.5	4.5	—	26	—	—	—	
Control Input Capacitance	C_{IN}		—	—	—	5	10	—	10	pF
Common Terminal Capacitance	C_{IS}		-5.0	5.0	—	11	20	—	20	pF
Switch Terminal Capacitance	C_{OS}		-5.0	5.0	—	7	15	—	15	pF
Feed Through Capacitance	C_{IOS}		-5.0	5.0	—	0.75	2	—	2	pF
Power Dissipation Capacitance	C_{PD}	(Note 1)	GND	5.0	—	67	—	—	—	pF

(Note 1) : C_{PD} is defined as the value of the internal equivalent capacitance which is calculated from the operating current consumption without load.

Average operating current can be obtained by the equation :

$$I_{CC(opr)} = C_{PD} \cdot V_{CC} \cdot f_{IN} + I_{CC} / 2$$

ANALOG SWITCH CHARACTERISTICS (GND = 0V, Ta = 25°C)

CHARACTERISTIC		TEST CONDITION		V _{EE}	V _{CC}	TYP.	UNIT
				(V)	(V)		
Sine Wave Distortion (T.H.D)		R _L = 10kΩ, C _L = 50pF f _{IN} = 1kHz	V _{IN} = 4.0V _{p-p}	- 2.25	2.25	0.025	%
			V _{IN} = 8.0V _{p-p}	- 4.5	4.5	0.02	
			V _{IN} = 1.1V _{p-p}	- 6.0	6.0	0.018	
Frequency Response (Switch ON)	f _{MAX}	Adjust f _{IN} voltage to obtain 0dBm at V _{OS} Increase f _{IN} until dB Meter reads - 3dB R _L = 50Ω, C _L = 10pF f _{IN} = 1MHz, Sine Wave	*1	- 2.25	2.25	120	MHz
			*2			95	
			*1	- 4.5	4.5	190	
			*2			150	
			*1	- 6.0	6.0	200	
			*2			190	
Feedthrough Attenuation (Switch OFF)		Vin is centered at (V _{CC} -V _{EE})/2 Adjust input for 0dBm R _L = 600Ω, C _L = 50pF f _{IN} = 1MHz, Sine Wave		- 2.25	2.25	- 50	dB
				- 4.5	4.5	- 50	
				- 6.0	6.0	- 50	
Crosstalk (Control Input to Signal Output)		R _L = 600Ω, C _L = 50pF f _{IN} = 1MHz, Square Wave (t _r = t _f = 6ns)		- 2.25	2.25	60	mV
				- 4.5	4.5	140	
				- 6.0	6.0	200	
Crosstalk (Between any switches)		Adjust V _{IN} to obtain 0dBm at Input R _L = 600Ω, C _L = 50pF f _{IN} = 1MHz, Sine Wave		- 2.25	2.25	- 50	dB
				- 4.5	4.5	- 50	
				- 6.0	6.0	- 50	

*1 : Input COMMON Terminal, and measured at SWITCH Terminal.

*2 : Input SWITCH Terminal, and measured at COMMON Terminal.

(Note): These characteristics are determined by design of device.

SWITCHING CHARACTERISTICS TEST CIRCUITS

1. t_{pLZ} , t_{pHZ} , t_{pZL} , t_{pZH}

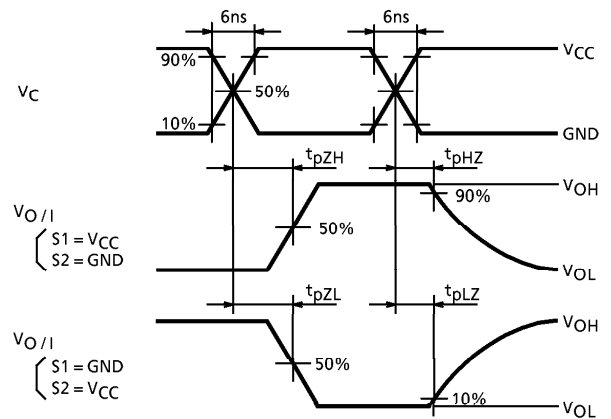
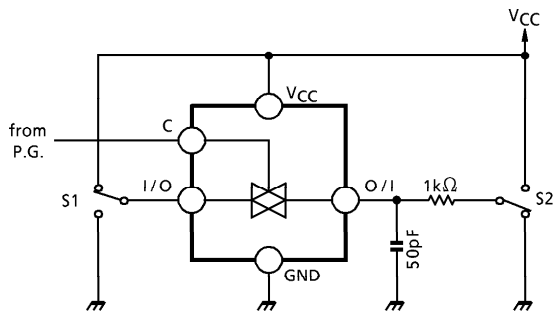

2. CROSS TALK (CONTROL INPUT-SWITCH OUTPUT)

$f_{in} = 1\text{MHz}$, $\text{duty} = 50\%$, $t_r = t_f = 6\text{ns}$

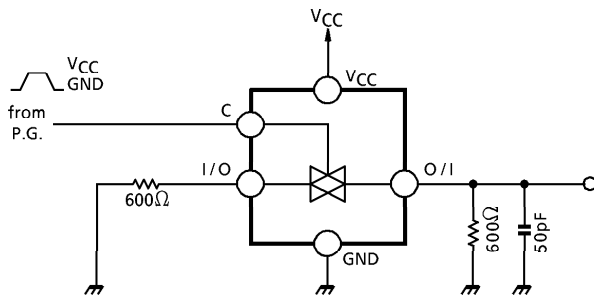

3. FEEDTHROUGH ATTENUATION

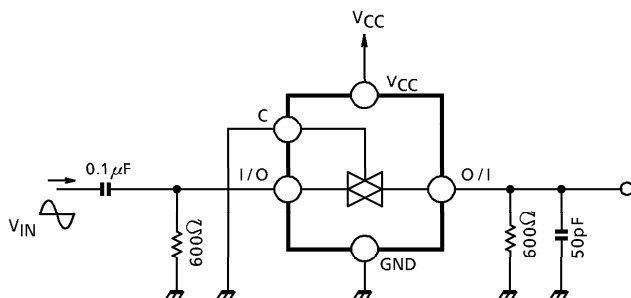

4. Clos, $C_{I/O}$

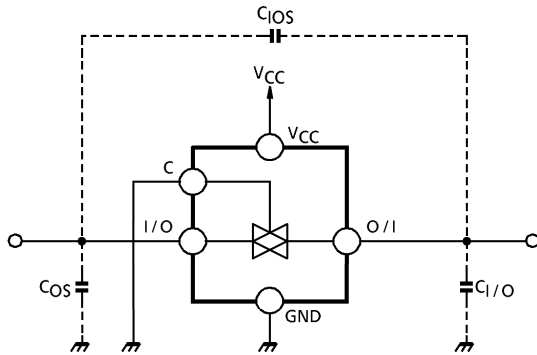

5. CROSS TALK (BETWEEN ANY TWO SWITCHES)

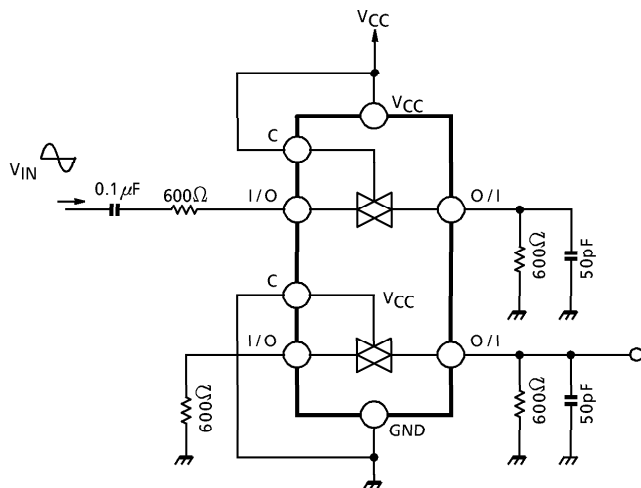

6. FREQUENCY RESPONSE (SWITCH ON)

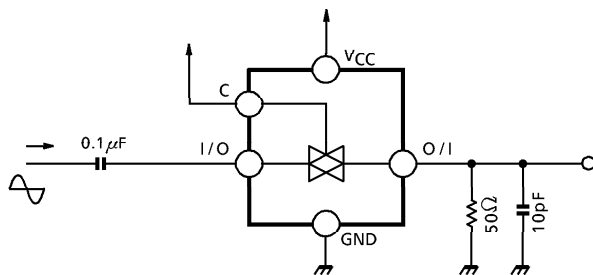

OUTLINE DRAWING
SOP8-P-1.27

Unit : mm

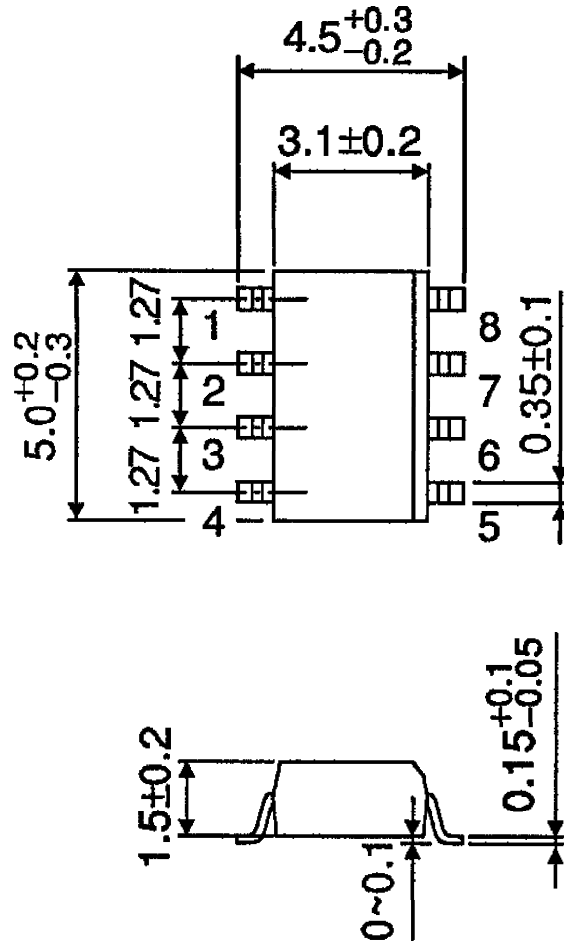

Weight : 0.05g (Typ.)

OUTLINE DRAWING
SSOP8-P-0.65

Unit : mm

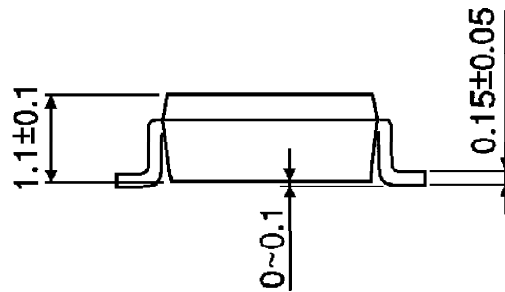
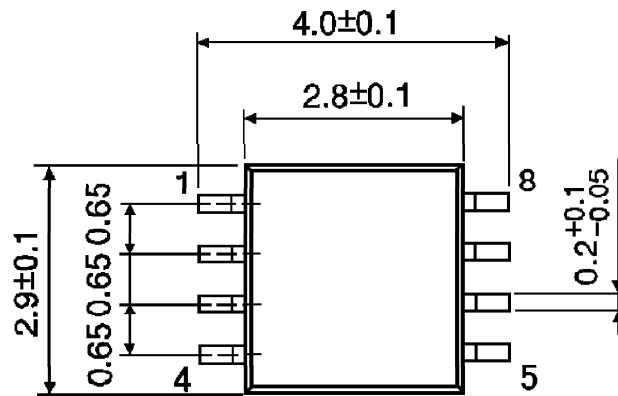

Weight : 0.02g (Typ.)

OUTLINE DRAWING
SSOP8-P-0.50A

Unit : mm

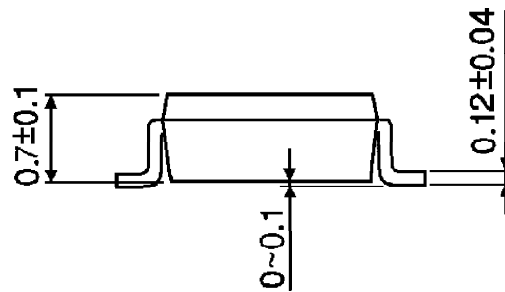
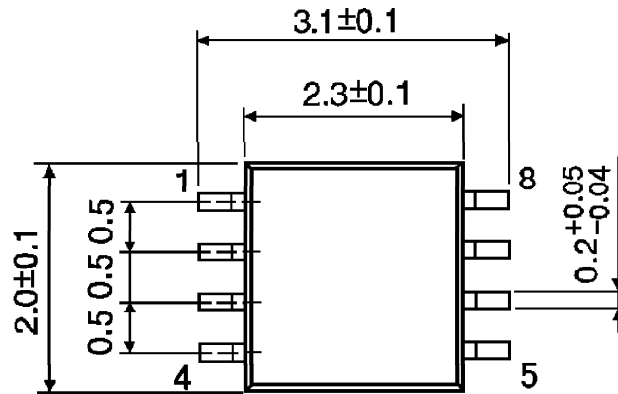

Weight : 0.01g (Typ.)