

Ordering number : EN*5382

CMOS LSI



LC89210

High-speed fax modem data pump

Preliminary

Overview

The LC89210 is a highly integrated modem engine that can be used in products that support transmission rates up to the 14,400 bps rate used in contemporary group III fax equipment. The LC89210 is compatible with V.21, V.23 and Bell 103 full-duplex modems.

Features

- Supports the ITU-T V.17, V.29, and V.27ter fax standards
- ITU-T V.23, V.21, and Bell 103
- V.17, V.29 (T104), and V.27ter short training
- V.33 half duplex
- 1800-Hz or 1700-Hz carrier
- The LC89210 is a complete data pump on a single chip.
- 5 V single-voltage power supply
 - Operating power dissipation: 375 mW (typical)
 - Low power mode: 5 mW (typical)
- Expanded operating modes
 - Full implementation of V.17, V.33, V.29, and V.27ter handshaking
 - Autodial and autoanswer functions
 - Programmable tone detection and FSK V.21 flag pattern detection during high-speed reception
 - Programmable call progress and call waiting tone detection, including DTMF
 - Support for programmable CLASS™ detection
 - Wide dynamic range (better than 48 dB)
 - A-law voice PCM mode
- Multiple interfaces
 - Parallel 64 ×8-bit dual-port RAM
 - Synchronous/HDLC parallel data processing
 - Support for HDLC framing
 - V.24 interface
 - Can monitor all operating states in real time.
 - Includes all diagnostic functions.
 - Dual 8-bit D/A converter for eye pattern display

Package Dimensions

unit: mm

3213-PQFP64

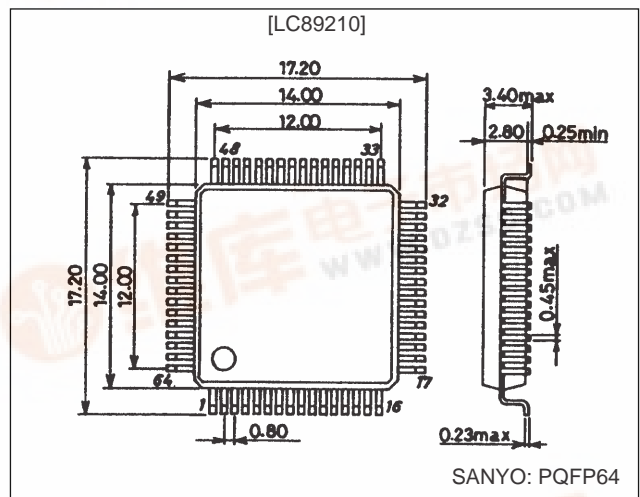

LC89210

Specifications

Electrical Specifications at Ta = 25°C, V_{DD} = 5 V (unless otherwise specified)

Absolute Maximum Ratings with respect to ground

Parameter	Symbol	Conditions	Ratings	Unit
DC supply voltage	V _{DD}		-0.3 to +7.0	V
Digital or analog input voltage	V _I , V _{IN}		-0.3 to (V _{DD} + 0.3)	V
Digital or analog input current	I _I , I _{IN}		±1	mA
Digital output current	I _O		±20	mA
Analog output current	I _{OUT}		±10	mA
Allowable power dissipation	Pd max		1000	mW
Operating temperature	Topr		0 to +70	°C
Storage temperature (plastic)	Tstg		-40 to +125	°C

Electrical Characteristics at Ta = 0 to +70°C, V_{DD} = 5.0 V ± 5%, GND = 0 V (unless otherwise specified)

Parameter	Symbol	Conditions	min	typ	max	Unit
[Power Supply and Common-Mode Voltages]						
Supply voltage	V _{DD}		4.75	5	5.25	V
Current drain	I _{DD}			75	100	mA
Current drain in lower power mode	I _{DD-ip}			1		mA
Common-mode voltage	V _{CM}		V _{DD} /2 - 5%	V _{DD} /2	V _{DD} /2 + 5%	V
[Crystal Oscillator Interface] XTAL and EXTAL						
Input low-level voltage	V _{IL}				1.5	V
Input high-level voltage	V _{IH}		3.5			V
Input low-level current	I _L	GND < V _I < V _{IL} max	-15			μA
Input high-level current	I _H	V _{IH} min < V _I < V _{DD}			15	μA
[Digital Interface] All digital pins except the XTAL pin						
Input low-level voltage	V _{IL}		-0.3		+0.8	V
Input high-level voltage	V _{IH}		2.2			V
Input current	I _I	V _I = V _{DD} or V _I = GND	-10	0	+10	μA
Output high-level voltage	V _{OH}	I _{load} = 2 mA	2.4			V
Output low-level voltage	V _{OL}	I _{load} = 2 mA			0.4	V
3-state input leakage current	I _{OZ}	GND < V _O < V _{DD}	-50	0	+50	μA
Input capacitance	C _{IN}			5		pF
[Analog Interface]						
Differential reference voltage input	V _{REF}	V _{REFP} - V _{REFN}	2.40	2.50	2.60	V
Input common-mode offset	V _{CMOin}	V = (RXA1 + RXA2)/2 - V _{CM}	-300		+300	mV
Differential input voltage	V _{DIFin}	RXA1 - RXA2			2 × V _{REF}	Vp-p
Output common-mode voltage offset	V _{CMOout}	(TXA1 + TXA2)/2 - V _{CM}	-200		+200	mV
Differential output voltage	V _{DIFout}	TXA1 - TXA2			2 × V _{REF}	Vp-p
Differential output DC offset	V _{OFFout}	(TXA1 - TXA2)	-100		+100	mV
Input resistance	R _{in}	RXA _X	100			kΩ
Output resistance	R _{out}	TXA _X			20	Ω
Load resistance	R _L	TXA _X	10			kΩ
Load capacitance	C _L	TXA _X			50	pF

LC89210

Pin Assignment

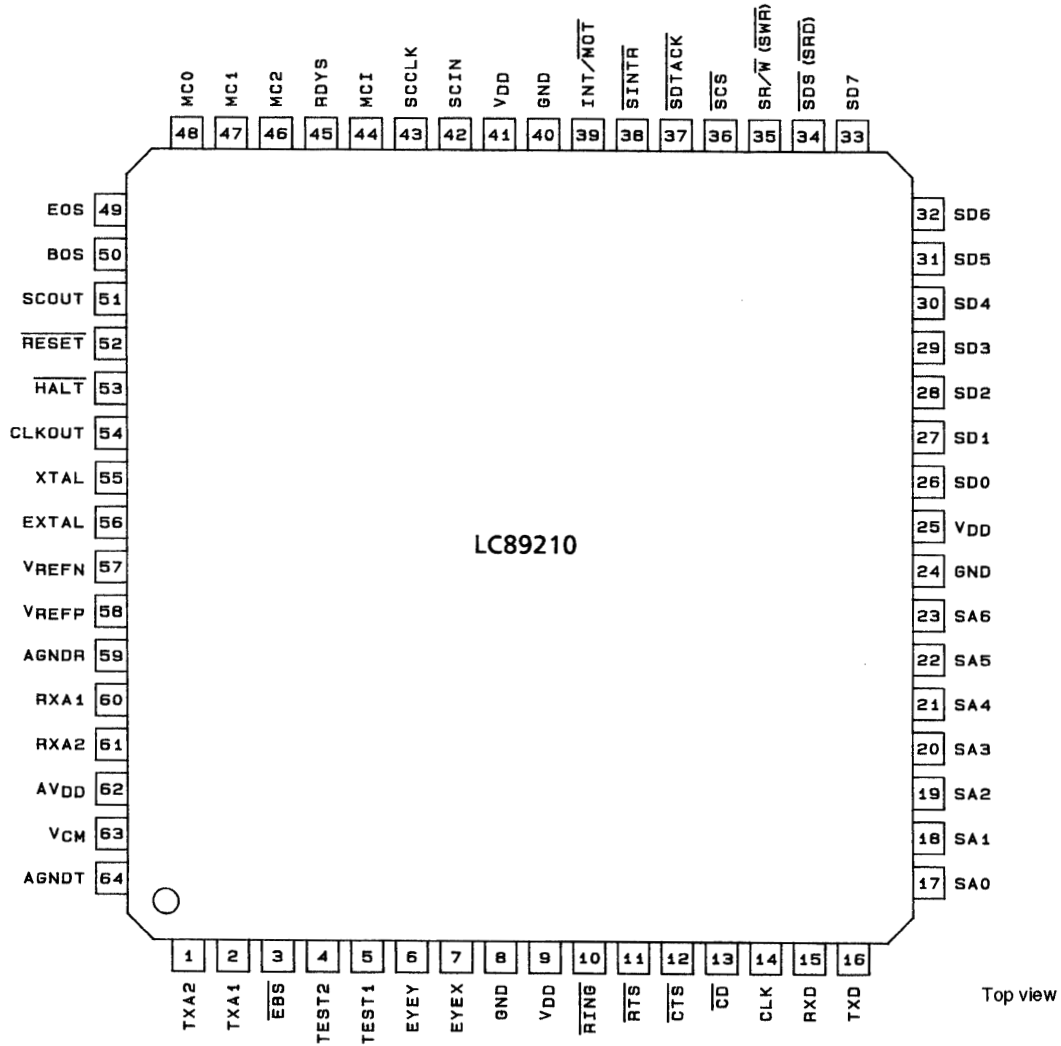

A04075

Host Interface

The LC89210 is interfaced to the control processor through a 64-byte dual-port RAM that is shared by the LC89210 and the host.

Pin	Type	Function
SD0 to SD7	I/O	System data bus
SA0 to SA6	I	System address bus
$\overline{\text{SDS}}$ (SDR)	I	System data strobe
$\overline{\text{SR/W}}$ (SWR)	I	System read/write
$\overline{\text{SCS}}$	I	System chip select
$\overline{\text{SDTACK}}$	OD*	System bus data acknowledge
$\overline{\text{SINTR}}$	OD*	System interrupt request
$\overline{\text{RESET}}$	I	Reset. This is an active-low signal.
$\overline{\text{RING}}$	I	Ring detect signal
$\overline{\text{INT/MOT}}$	I	Intel/Motorola interface

Note: * Open-drain output

LC89210

Analog Interface

Pin	Type	Function
TXA1	O	Transmission analog output 1
TXA2	O	Transmission analog output 2
RXA1	I	Reception analog input 1
RXA2	I	Reception analog input 2
V _{CM}	I/O	Analog common voltage (nominal value: +2.5 V)
V _{REFN}	I	Analog negative reference voltage (nominal value: CM – 1.25 V)
V _{REFP}	I	Analog positive reference voltage (nominal value: CM + 1.25 V)

V.24 Interface

Pin	Type	Function
$\overline{\text{RTS}}$	I	Transfer request. This is an active-low signal.
CLK	O	Data bit clock
$\overline{\text{CTS}}$	O	Clear to send. This is an active-low signal.
RXD	O	Reception data
TXD	I	Transfer data
$\overline{\text{CD}}$	O	Carrier detect. This is an active-low signal.

Other Interfaces

Pin	Type	Function
XTAL	O	Internal oscillator output
EXTAL	I	Internal oscillator input or external clock
EYEX	O	Constellation X analog coordinate (eye pattern)
EYFY	O	Constellation Y analog coordinate (eye pattern)
TEST1		This pin must be left open
TEST2		This pin must be left open

Note: The LC89210 nominal external clock frequency is 29.4912 MHz. This value has a precision of $\pm 5 \cdot 10^{-5}$.

Boundary Scan Interface

The LC89210 provides 13 signals for testing. These signals can be used along with the SGS-Thomson ST18932 boundary scan development tools in the product development process to debug application hardware and software. If this function is not used, all of these input signal must be connected to ground, and all of these output signals must be left open.

Pin	Type	Function
SCIN	I	Scan data input
SCCLK	I	Scan clock
SCOUT	O	Scan data output
BOS	I	Scan control start
EOS	I	Scan stop
MC0 to MC2	I	Mode control
HALT	I	LC89210 execution step
MC1	O	Multi-cycle instruction
RDYS	O	Scan flag ready
EBS	I	Enable boundary scan
CLKOUT	O	LC89210 internal clock (the crystal oscillator frequency divided by 2)

LC89210

Power Supply

Symbol	Parameter
V _{DD}	Digital +5 V (pins 9, 25, and 41)
GND	Digital ground (pins 8, 24, and 40)
AV _{DD}	Analog +5 V (pin 62)
AGNDT	Analog transmission system ground (pin 64)
AGNDR	Analog reception system ground (pin 59)

Block Diagrams

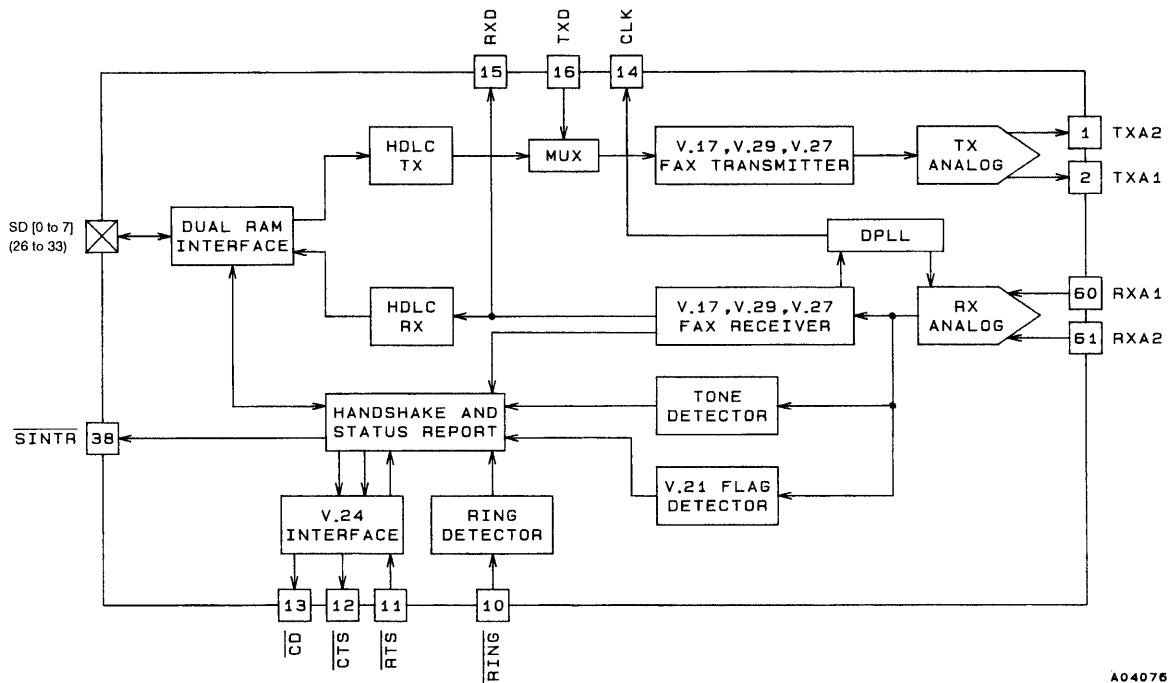

A04076

Function Block Diagram

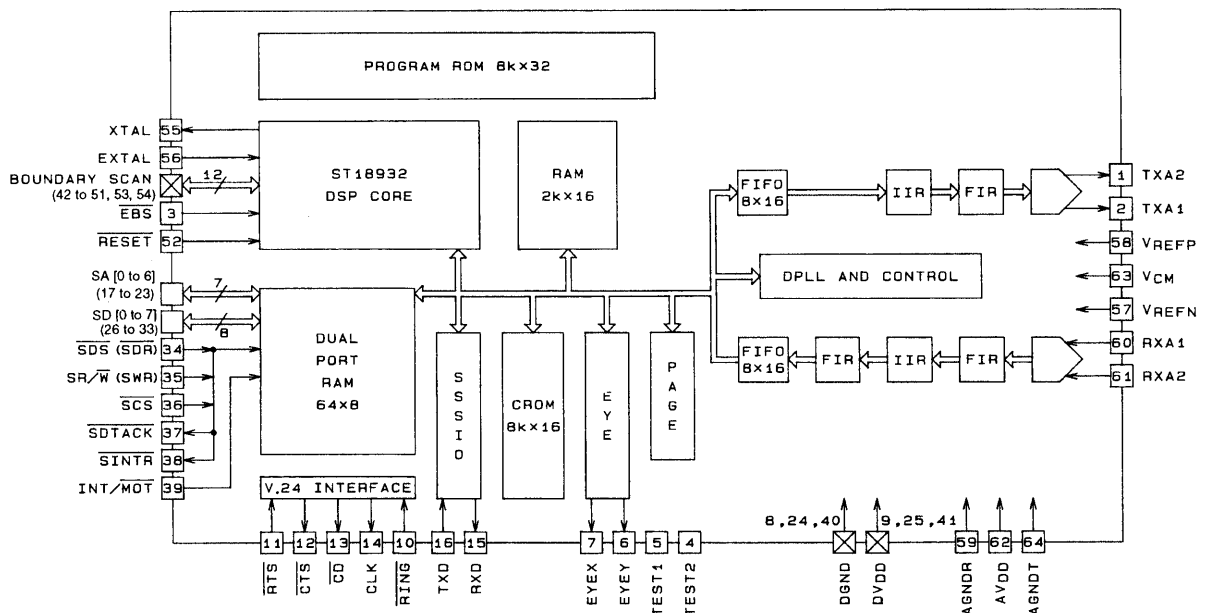

A04077

Hardware Block Diagram

AC Electrical Characteristics

Dual-Port RAM Host Timing

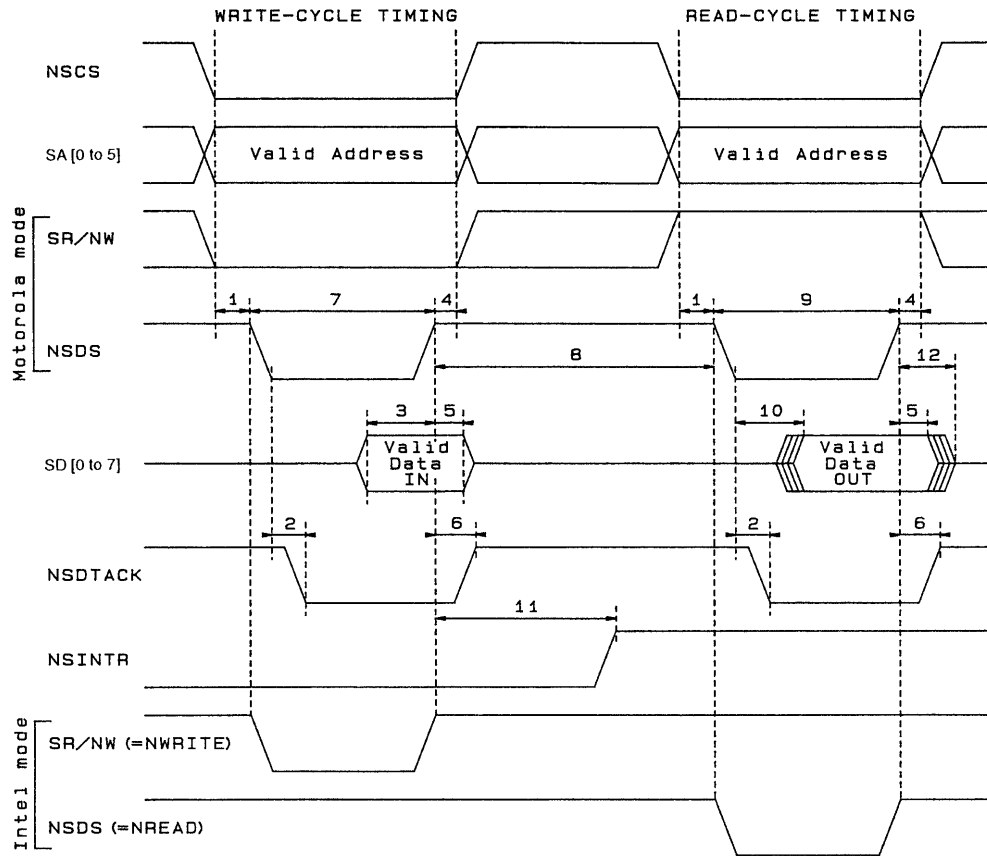

A05273

Parameter	Number	Conditions	min	typ	max	Unit
Address and control setup time	1		5			ns
SDTACK acknowledge	2				20	ns
Data setup time	3		10			ns
Address and control hold time	4		0			ns
Data hold time	5		5			ns
SDTACK hold time	6		0			ns
Write enable low state	7		45			ns
Access inhibition high state	8		70*			ns
Read enable low state	9		45			ns
Read data access	10				35	ns
SINTR clear delay	11				50	ns
Data valid to tristate	12				15	ns

Note: * The minimum delay of 70 ns is the time from the rising edge of NWRITE to the next falling edge on either NREAD or NWRITE.

LC89210

Serial V.24 Interface Timing

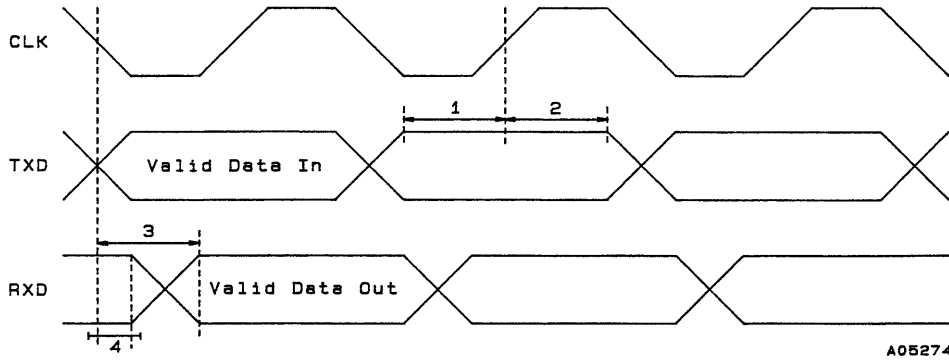

Parameter	Number	Conditions	min	typ	max	Unit
TXD to CLK setup time	1		30			ns
TXD to CLK hold time	2		10			ns
RXD valid to CLK delay time	3				100	ns
RXD valid to CLK hold time	4		0			ns

LC89210

Electrical Circuit Diagrams

Oscillator

We recommend the use of the following circuit if an overtone crystal oscillator is used in series resonance mode.

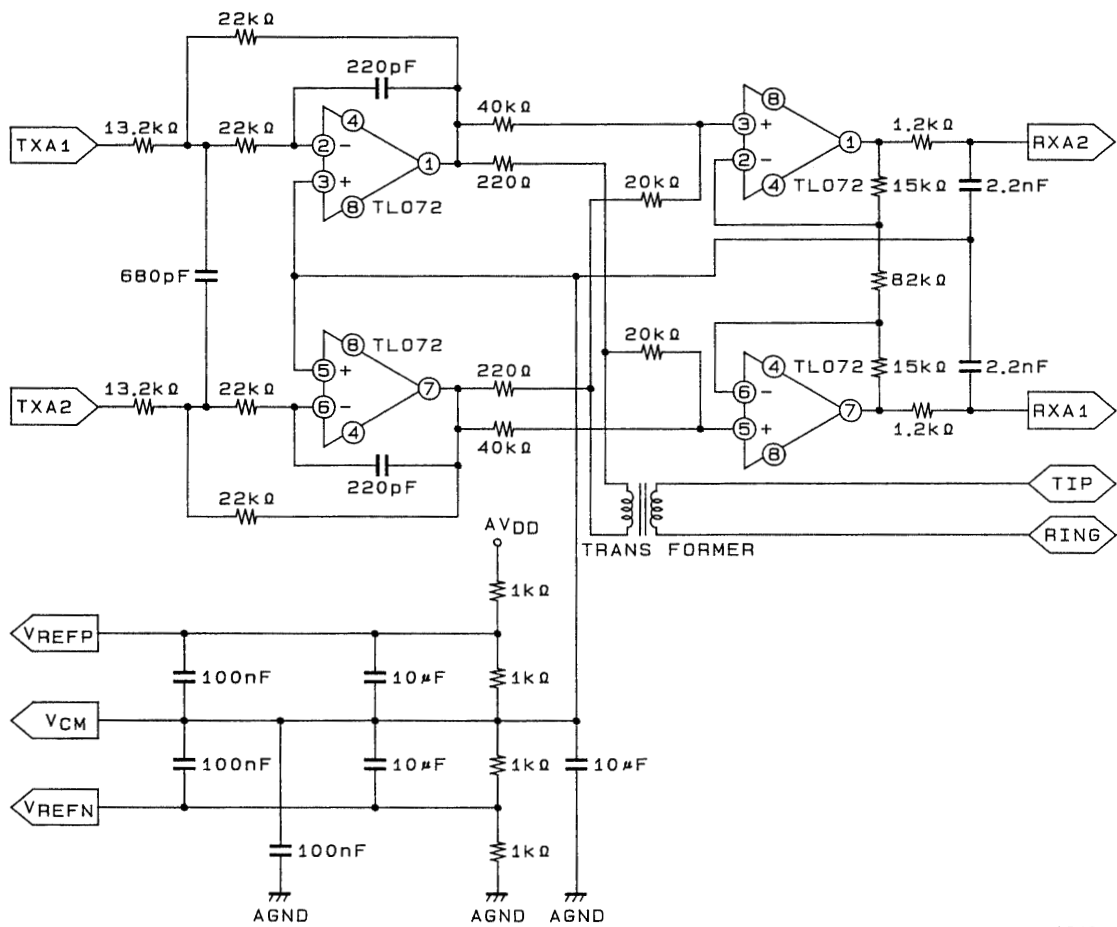
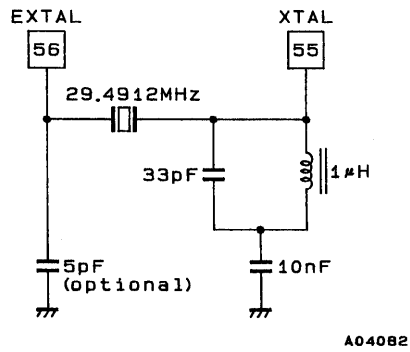

LC89210

Printed Circuit Board Design Guidelines

While the two most important factors influencing the performance of this fax modem are the performance of the LC89210 itself and the appropriateness of the design of the printed circuit board, it is not the purpose of this section to describe all aspects of modem printed circuit board design. Rather, this section presents the following few recommendations.

1. 4-layer boards

The digital and analog system grounds should be separated and then connected at a single point (single-point ground). Furthermore, the location of the single-point ground should be as close to the LC89210 as is possible. AGNDR and AGNDT should be connected to the single-point ground location with an extremely low impedance.

2. 2-layer boards

Supply the ground grid to all empty spaces and the inner side of component spaces.

3. The 2.2 nF capacitors connected to the RXA1 and RXA2 pins should be located as close to the pins as possible.
4. The two 100 nF capacitors connected to the V_{REFP} and V_{REFN} pins should be located as close to the pins as possible.
5. To prevent latchup due to differences in power on timing between the analog and digital power supplies, insert two diodes with reverse polarities in parallel between the V_{DD} (digital) and AV_{DD} (analog) power supplies.

Application Example

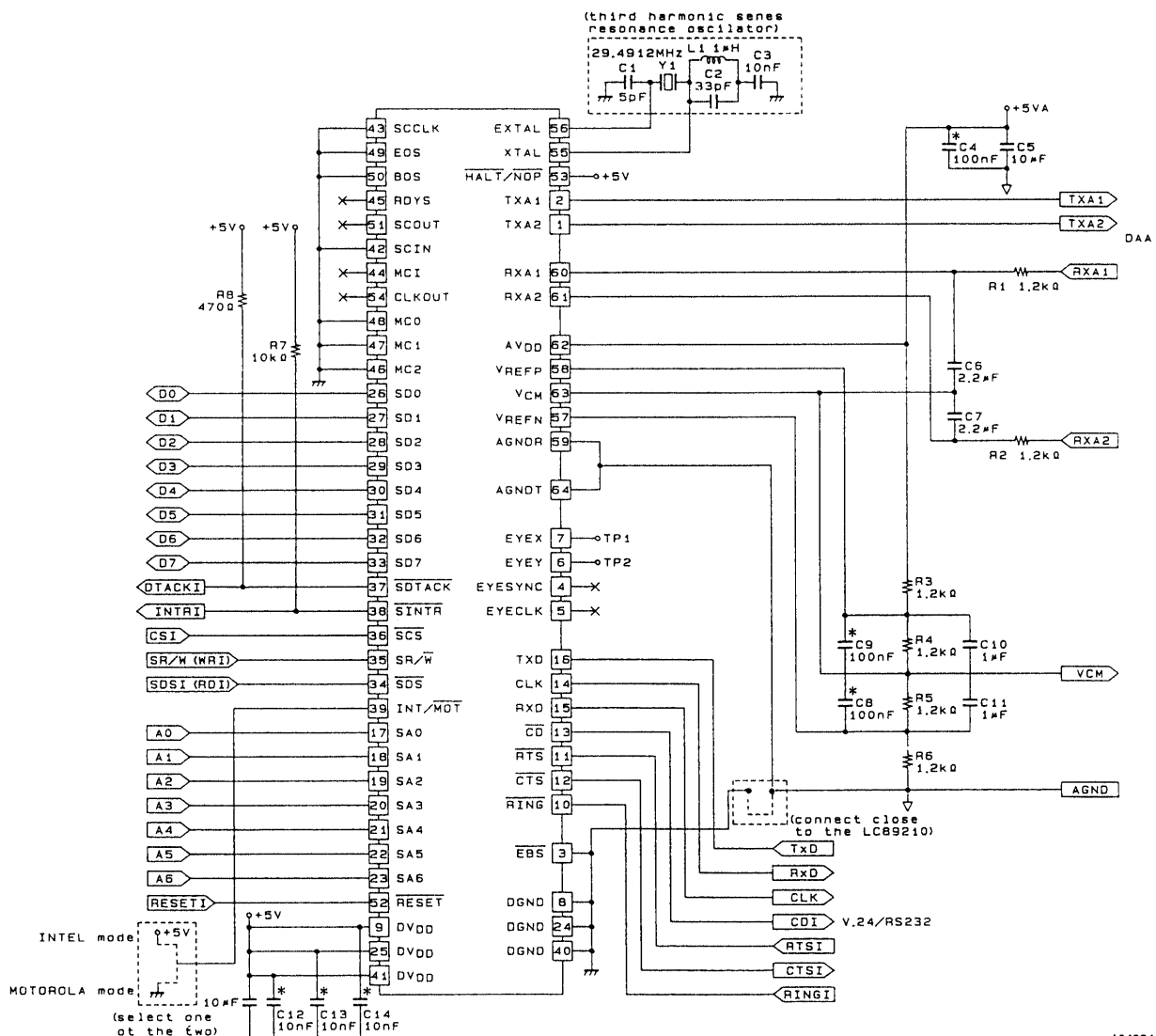

Note: The capacitors marked with asterisks (*) must be connected as close as possible to the LC89210 pins. Signal names ending in "I" are active low signals. If it is necessary to supply current to V_{CM}, add the resistors R3, R4, R5, and R6.

- No products described or contained herein are intended for use in surgical implants, life-support systems, aerospace equipment, nuclear power control systems, vehicles, disaster/crime-prevention equipment and the like, the failure of which may directly or indirectly cause injury, death or property loss.
- Anyone purchasing any products described or contained herein for an above-mentioned use shall:
 - ① Accept full responsibility and indemnify and defend SANYO ELECTRIC CO., LTD., its affiliates, subsidiaries and distributors and all their officers and employees, jointly and severally, against any and all claims and litigation and all damages, cost and expenses associated with such use:
 - ② Not impose any responsibility for any fault or negligence which may be cited in any such claim or litigation on SANYO ELECTRIC CO., LTD., its affiliates, subsidiaries and distributors or any of their officers and employees jointly or severally.
- Information (including circuit diagrams and circuit parameters) herein is for example only; it is not guaranteed for volume production. SANYO believes information herein is accurate and reliable, but no guarantees are made or implied regarding its use or any infringements of intellectual property rights or other rights of third parties.