

# CA3085, CA3085A CA3085B

Positive Voltage Regulators from  
1.7V to 46V at Currents Up to 100mA

April 1994

## Features

- Up to 100mA Output Current
- Input and Output Short-Circuit Protection
- Load and Line Regulation..... 0.025%
- Pin Compatible with LM100 Series
- Adjustable Output Voltage

## Applications

- Shunt Voltage Regulator
- Current Regulator
- Switching Voltage Regulator
- High-Current Voltage Regulator
- Combination Positive and Negative Voltage Regulator
- Dual Tracking Regulator

TYPE	V <sub>IN</sub> RANGE (V)	V <sub>OUT</sub> RANGE (V)	MAX I <sub>OUT</sub> (mA)	MAX LOAD REGULATION (%V <sub>OUT</sub> )
CA3085	7.5 to 30	1.8 to 28	12 (Note 1)	0.1
CA3085A	7.5 to 40	1.7 to 38	100	0.15
CA3085B	7.5 to 50	1.7 to 46	100	0.15

NOTE:

1. This value may be extended to 100mA; however, regulation is not specified beyond 12mA.

## Description

The CA3085, CA3085A, and CA3085B are silicon monolithic integrated circuits designed specifically for service as voltage regulators at output voltages ranging from 1.7V to 46V at currents up to 100 milliamperes.

A block diagram of the CA3085 Series is shown. The diagram shows the connecting terminals that provide access to the regulator circuit components. The voltage regulators provide important features such as: frequency compensation, short-circuit protection, temperature-compensated reference voltage, current limiting, and booster input. These devices are useful in a wide range of applications for regulating high-current, switching, shunt, and positive and negative voltages. They are also applicable for current and dual-tracking regulation.

The CA3085A and CA3085B have output current capabilities up to 100mA and the CA3085 up to 12mA without the use of external pass transistors. However, all the devices can provide voltage regulation at load currents greater than 100mA with the use of suitable external pass transistors. The CA3085 Series has an unregulated input voltage ranging from 7.5V to 30V (CA3085), 7.5V to 40V (CA3085A), and 7.5V to 50V (CA3085B) and a minimum regulated output voltage of 28V (CA3085), 36V (CA3085A), and 46V (CA3085B).

## Ordering Information

PART NUMBER	TEMPERATURE RANGE	PACKAGE
CA3085, A, B	-55°C to +125°C	8 Pin Metal Can
CA3085E, AE, BE	-55°C to +125°C	8 Lead Plastic DIP

## Pinouts

CA3085, A, B, E, AE, BE (PDIP)  
TOP VIEW

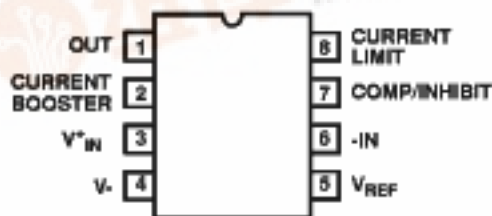

CA3085S, AS, BS (CAN)  
TOP VIEW

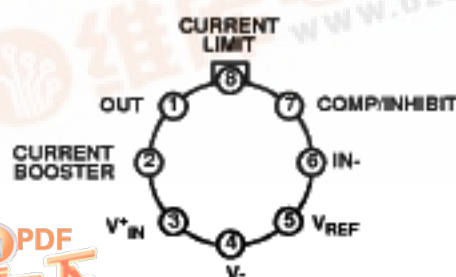

## Functional Block Diagram

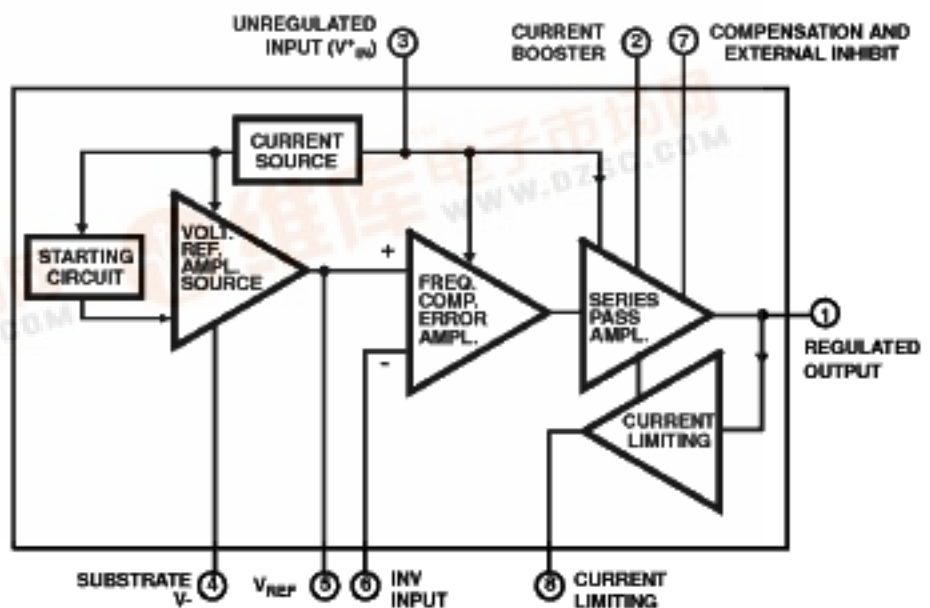

## Specifications CA3085, CA3085A, CA3085B

### Absolute Maximum Ratings

Supply Voltage	+7.0V
Unregulated Input Voltage	
CA3085	30V
CA3085A	40V
CA3085B	50V
Storage Temperature Range	-65°C to +150°C
Junction Temperature	+175°C
Plastic DIP Package	+150°C
Lead Temperature (Soldering 10s)	+265°C

### Thermal Information

Thermal Resistance	$\theta_{JA}$	$\theta_{JC}$
Metal Can (Without Heat Sink)	156°C/W	68°C/W
Plastic DIP Package	155°C/W	-
Maximum Package Power Dissipation		
Plastic DIP (Without Heat Sink)		
Up to $T_A = 55^\circ\text{C}$	630mW	
Above $T_A = 55^\circ\text{C}$	Derate Linearly at 6.67mW/°C	
Metal Can (With Heat Sink)		
Up to $T_C = 55^\circ\text{C}$	1.6W	
Above $T_C = 55^\circ\text{C}$	Derate Linearly at 16.7mW/°C	

*CAUTION: Stresses above those listed in "Absolute Maximum Ratings" may cause permanent damage to the device. This is a stress only rating and operation of the device at these or any other conditions above those indicated in the operational sections of this specification is not implied.*

### Operating Conditions

Operating Voltage Range	+1.7V to +46V	Operating Temperature Range	-55°C to +125°C
-------------------------	---------------	-----------------------------	-----------------

### Maximum Voltage Ratings

The following chart gives the range of voltages which can be applied to the terminal listed vertically with respect to the terminals listed horizontally. For example, the voltage range between vertical Terminal Number 7 and horizontal Terminal Number 1 is +3 to -10V.

TERMINAL NUMBER	5	6	7	8	1	2	3	4
5	-	+5 -5	Note 1	Note 1	Note 1	Note 1	Note 1	+10 0
6	-	-	Note 1	Note 1	Note 1	Note 1	Note 1	Note 1
7	-	-	-	+3 -10	-103	Note 1	Note 1	+(Note 2) 0
8	-	-	-	-	+5 -1	Note 1	Note 1	Note 1
1	-	-	-	-	-	+10 -(Note 2)	0 -(Note 2)	+(Note 2) 0
2	-	-	-	-	-	-	0 -	+(Note 2) 0
3	-	-	-	-	-	-	-	+(Note 2) 0
4	-	-	-	-	-	-	-	Substrate and Case

#### NOTES:

- Voltages are not normally applied between these terminals; however, voltages appearing between these terminals are safe, if the specified voltage limits between all other terminals are not exceeded.
- 30V (CA3085); 40V (CA3085A); 50V (CA3085B)

### Maximum Current Ratings

TERMINAL NUMBER	$I_{IN}$ (mA)	$I_{OUT}$ (mA)
5	10	1.0
6	1.0	-0.1
7	1.0	-0.1
8	0.1	10
1	20	150
2	150	60
3	150	60
4	-	-

## Specifications CA3085, CA3085A, CA3085B

### DC Electrical Specifications $T_A = +25^\circ\text{C}$ , Unless Otherwise Specified

PARAMETERS	SYMBOL	TEST CONDITIONS	CA3085			CA3085A			CA3085B			UNITS
			MIN	TYP	MAX	MIN	TYP	MAX	MIN	TYP	MAX	
DC CHARACTERISTICS												
Reference Voltage	$V_{REF}$	$V_{IN}^+ = 15\text{V}$ (Figure 3)	1.4	1.6	1.8	1.5	1.6	1.7	1.5	1.6	1.7	V
Quiescent Regulator Current	$I_{quiescent}$	$V_{IN}^+ = 30\text{V}$ (Figure 3)	-	3.3	4.5	-	-	-	-	-	-	mA
		$V_{IN}^+ = 40\text{V}$ (Figure 3)	-	-	-	-	3.65	5	-	-	-	mA
		$V_{IN}^+ = 50\text{V}$ (Figure 3)	-	-	-	-	-	-	-	4.05	7	mA
Input Voltage Range	$V_{IN(\text{range})}$		7.5	-	30	7.5	-	40	7.5	-	50	V
Maximum Output Voltage	$V_{O(\text{MAX})}$	$V_{IN}^+ = 30, 40, 50\text{V}$ (Note 1); $R_L = 365\Omega$ ; Term. No. 6 to GND (Figure 3)	26	27	-	36	37	-	46	47	-	V
Maximum Output Voltage	$V_{O(\text{MIN})}$	$V_{IN}^+ = 30\text{V}$ (Figure 3)	-	1.6	1.8	-	1.6	1.7	-	1.6	1.7	V
Input - Output Voltage Differential	$V_{IN} - V_{OUT}$		4	-	28	4	-	38	3.5	-	48	V
Limiting Current	$I_{LIM}$	$V_{IN}^+ = 16\text{V}$ , $V_{OUT}^+ = 10\text{V}$ , $R_{SCP} = 6\Omega$ (Note 2) (Figure 6)	-	96	120	-	96	120	-	96	120	mA
Load Regulation (Note 3)		$I_L = 1$ to $100\text{mA}$ , $R_{SCP} = 0$	-	-	-	-	0.025	0.15	-	0.025	0.15	% $V_{OUT}$
		$I_L = 1$ to $100\text{mA}$ , $R_{SCP} = 0$ , $T_A = 0^\circ\text{C}$ to $+70^\circ\text{C}$	-	-	-	-	0.035	0.6	-	0.035	0.6	% $V_{OUT}$
		$I_L = 1$ to $12\text{mA}$ , $R_{SCP} = 0$	-	0.003	0.1	-	-	-	-	-	-	% $V_{OUT}$
Line Regulation (Note 4)		$I_L = 1\text{mA}$ , $R_{SCP} = 0$	-	0.025	0.1	-	0.025	0.075	-	0.025	0.04	% $V$
		$I_L = 1\text{mA}$ , $R_{SCP} = 0$ , $T_A = 0^\circ\text{C}$ to $+70^\circ\text{C}$	-	0.04	0.15	-	0.04	0.1	-	0.04	0.08	% $V$
Equivalent Noise Output Voltage	$V_{NOISE}$	$V_{IN}^+ = 25\text{V}$ (Figure 10) $C_{REF} = 0$	-	0.5	-	-	0.5	-	-	0.5	-	mVp-p
		$C_{REF} = 0.22\mu\text{F}$	-	0.3	-	-	0.3	-	-	0.3	-	mVp-p
Ripple Rejection		$V_{IN}^+ = 25\text{V}$ , $f = 1\text{kHz}$ (Figure 11) $C_{REF} = 0$	-	50	-	-	50	-	45	50	-	dB
		$C_{REF} = 2\mu\text{F}$	-	56	-	-	56	-	50	56	-	dB
Output Resistance	$r_O$	$V_{IN}^+ = 25\text{V}$ , $f = 1\text{kHz}$ (Figure 11)	-	0.075	1.1	-	0.075	0.3	-	0.075	0.3	$\Omega$
Temperature Coefficient of Reference and Output Voltages	$V_{REF}, V_O$ (Note 4)	$I_L = 0$ , $V_{REF} = 1.6\text{V}$	-	0.0035	-	-	0.0035	-	-	0.0035	-	%/ $^\circ\text{C}$

## Specifications CA3085, CA3085A, CA3085B

### DC Electrical Specifications $T_A = +25^\circ\text{C}$ , Unless Otherwise Specified (Continued)

PARAMETERS	SYMBOL	TEST CONDITIONS	CA3085			CA3085A			CA3085B			UNITS
			MIN	TYP	MAX	MIN	TYP	MAX	MIN	TYP	MAX	
LOAD TRANSIENT RECOVERY TIME												
Turn On	$t_{ON}$	$V_{IN}^+ = 25\text{V}$ , +50mA Step (Figure 16)	-	1	-	-	1	-	-	1	-	$\mu\text{s}$
Turn Off	$t_{OFF}$	$V_{IN}^+ = 25\text{V}$ , -50mA Step (Figure 16)	-	3	-	-	3	-	-	3	-	$\mu\text{s}$
LOAD TRANSIENT RECOVERY TIME												
Turn On	$t_{ON}$	$V_{IN}^+ = 25\text{V}$ , $f = 1\text{kHz}$ , 2V Step	-	0.8	-	-	0.8	-	-	0.8	-	$\mu\text{s}$
Turn Off	$t_{OFF}$		-	0.4	-	-	0.4	-	-	0.4	-	$\mu\text{s}$

**NOTES:**

1. 30V (CA3085), 40V (CA3085A), 50V (CA3085B)
2.  $R_{SCP}$ : Short Circuit Protection Resistance
3. Load Regulation =  $[\Delta V_{OUT} \div V_{OUT}(\text{initial})] \times 100\%$
4. Line Regulation =  $[\Delta V_{OUT} \div V_{OUT}(\text{initial})(\Delta V_{IN})] \times 100\%$

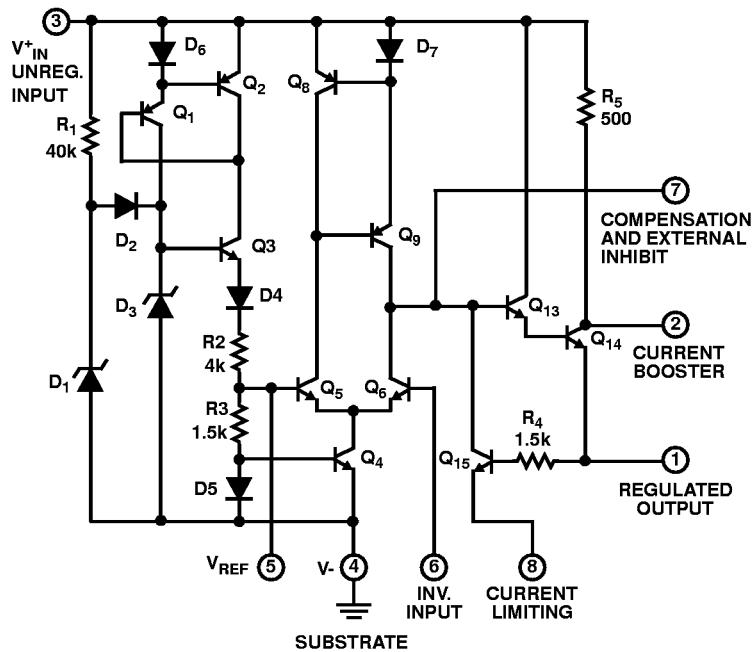

All Resistance Values are in Ohms

**FIGURE 1. SCHEMATIC DIAGRAM OF CA3085 SERIES**

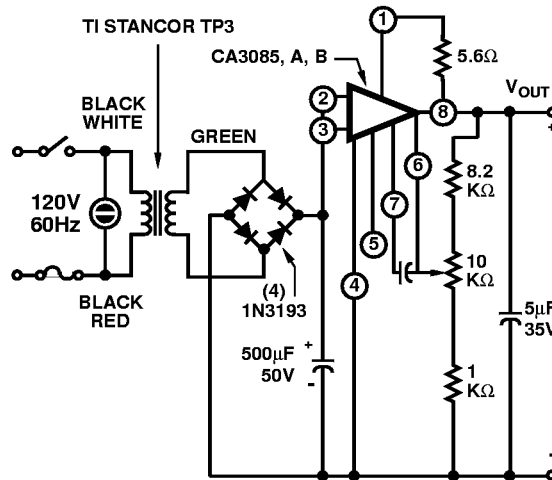

$V_{OUT} = 3.5\text{V to } 20\text{V}$  (0 to 90mA)  
 Regulation = 0.2% (Line and Load)  
 Ripple < 0.5mV at Full Load

**FIGURE 2. APPLICATION OF THE CA3085 SERIES IN A TYPICAL POWER SUPPLY**

## CA3085, CA3085A, CA3085B

### Test Circuits and Typical Performance Curves

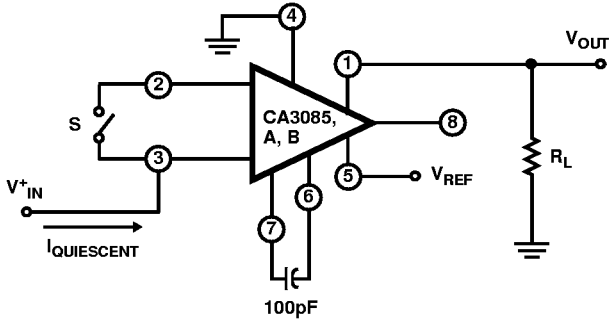

TEST	$R_L$	$V_{IN}$	CONNECT TERM NO. 6	S
$V_{REF}$	$\infty$	+1.6	Open	Open
$I_{QUIESCENT}$	$\infty$	+40	Open	Open
$V_{OUT(MAX)}$	365 $\Omega$	+40	Ground	Closed
$V_{OUT(MIN)}$	10K	+30	Terminal No.1	Open

FIGURE 3. TEST CIRCUIT FOR  $V_{REF}$ ,  $I_{QUIESCENT}$ ,  $V_{OUT(MAX)}$ ,  $V_{OUT(MIN)}$

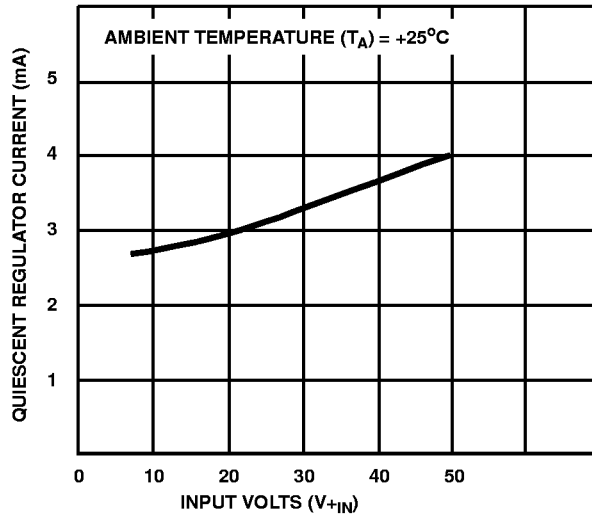

FIGURE 4.  $I_{QUIESCENT}$  vs  $V_{+IN}$

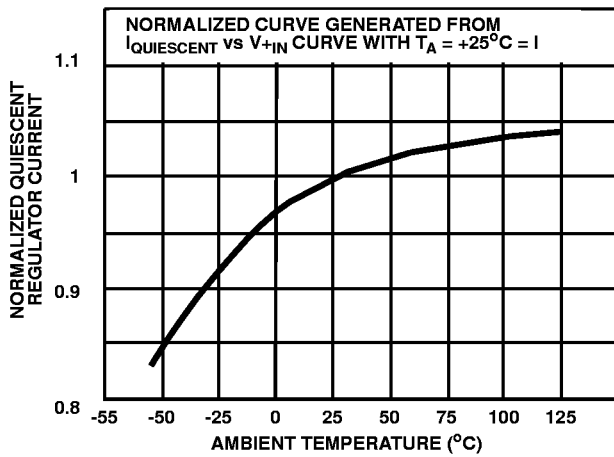
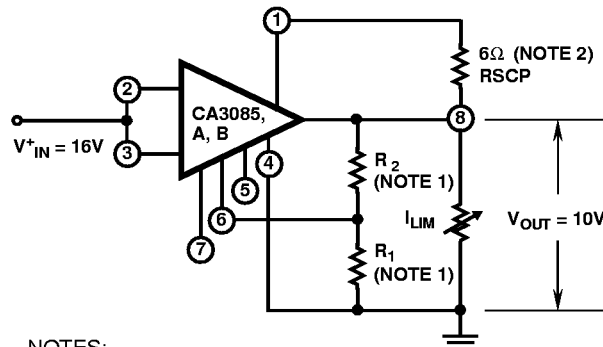

FIGURE 5. NORMALIZED  $I_{QUIESCENT}$  vs  $T_A$



NOTES:

- $V_{OUT} = 1.6 \times (R_1 + R_2 \div R_1)$
- The limits current is inversely proportional to  $R_{SCP}$

FIGURE 6. TEST CIRCUIT FOR LIMITING CURRENT

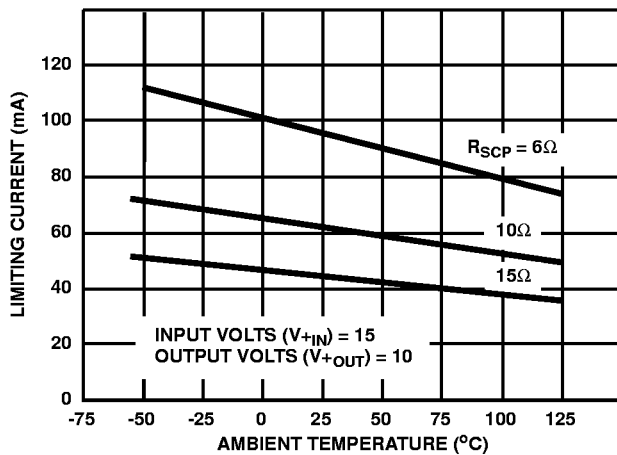

FIGURE 7.  $I_{LIM}$  vs  $T_A$

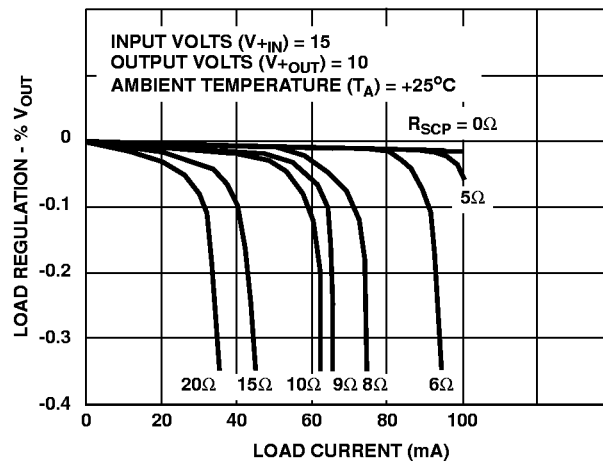

FIGURE 8. LOAD REGULATION CHARACTERISTICS

## CA3085, CA3085A, CA3085B

### Test Circuits and Typical Performance Curves (Continued)

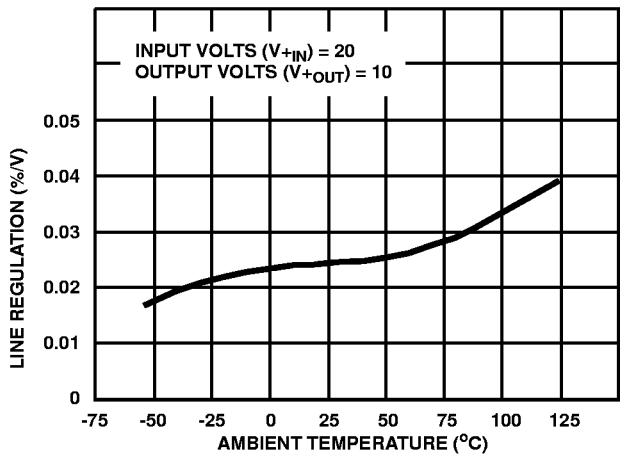

FIGURE 9. LINE REGULATION TEMPERATURE CHARACTERISTICS

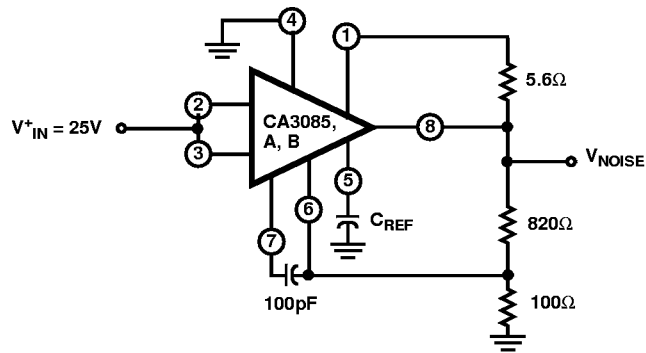

FIGURE 10. TEST CIRCUIT FOR NOISE VOLTAGE

#### TEST PROCEDURES FOR TEST CIRCUIT FOR RIPPLE REJECTION AND OUTPUT RESISTANCE

##### Output Resistance

Conditions

1.  $V_{IN} = +25V$ ,  $C_{REF} = 0$ , Short  $E_1$
2. Set  $E_{S2}$  at 1kHz so that  $E_2 = 4V_{RMS}$
3. Read  $V_{OUT}$  on a VTVM, such as a Hewlett-Packard, HP400D or Equivalent
4. Calculate  $R_{OUT}$  from  $R_{OUT} = V_{OUT}(R_L/E_2)$

##### Ripple Rejection - I

Conditions

1.  $V_{IN} = +25V$ ,  $C_{REF} = 0$ , Short  $E_2$
2. Set  $E_{S1}$  at 1kHz so that  $E_1 = 3V_{RMS}$
3. Read  $V_{OUT}$  on a VTVM, such as a Hewlett-Packard, HP400D or Equivalent
4. Calculate Ripple Rejection from  $20 \log (E_1/V_{OUT})$

##### Ripple Rejection - II

Conditions

1. Repeat Ripple Rejection I with  $C_{REF} = 2\mu F$

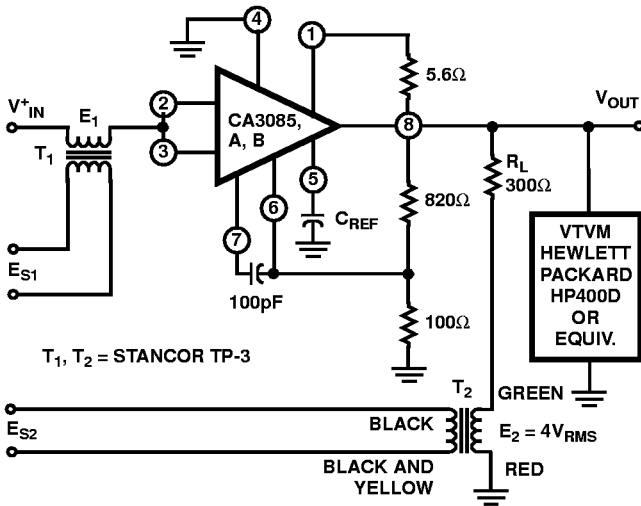

FIGURE 11. TEST CIRCUIT FOR RIPPLE REJECTION AND OUTPUT RESISTANCE

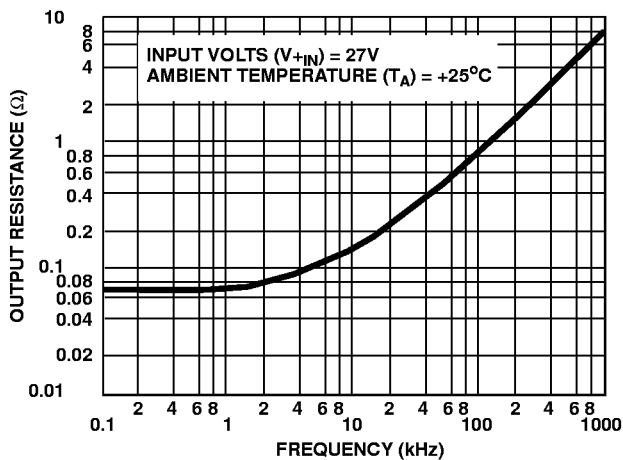

FIGURE 12.  $r_o$  vs  $f$

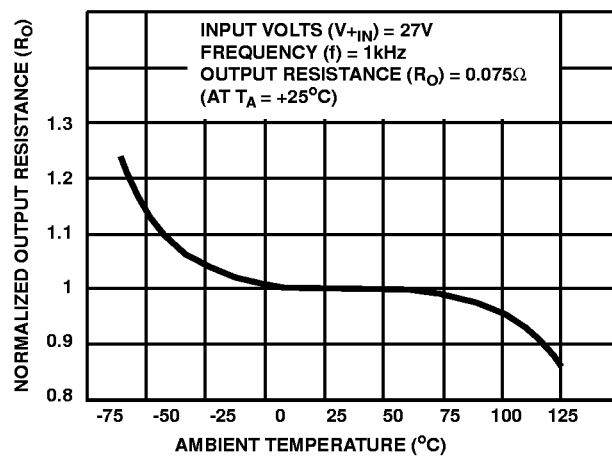

FIGURE 13. NORMALIZED  $r_o$  vs  $T_A$

CA3085, CA3085A, CA3085B

Test Circuits and Typical Performance Curves (Continued)

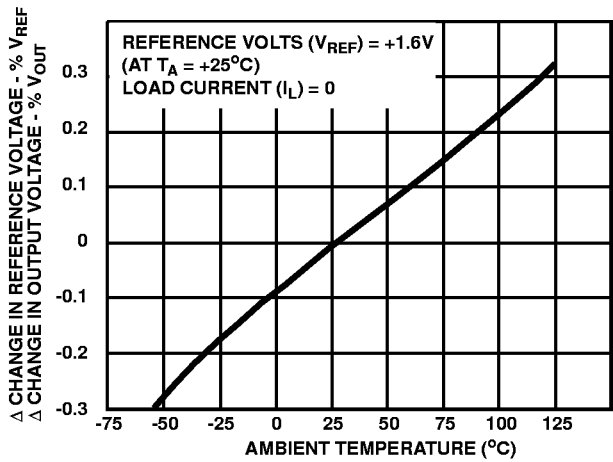

FIGURE 14. TEMPERATURE COEFFICIENT OF  $V_{REF}$  AND  $V_{OUT}$

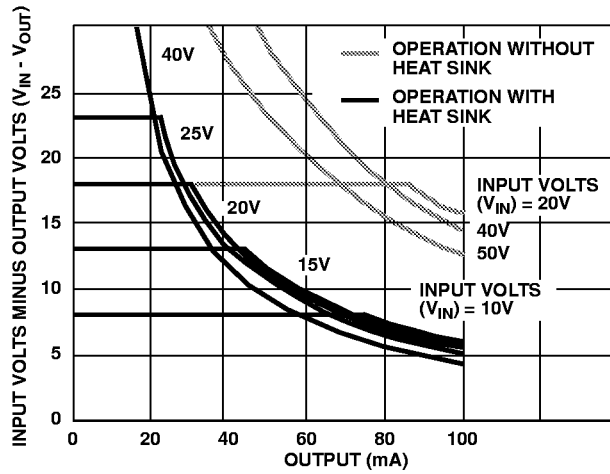

FIGURE 15. DISSIPATION LIMITATION ( $V_{IN} - V_{OUT}$  vs  $I_{OUT}$ )

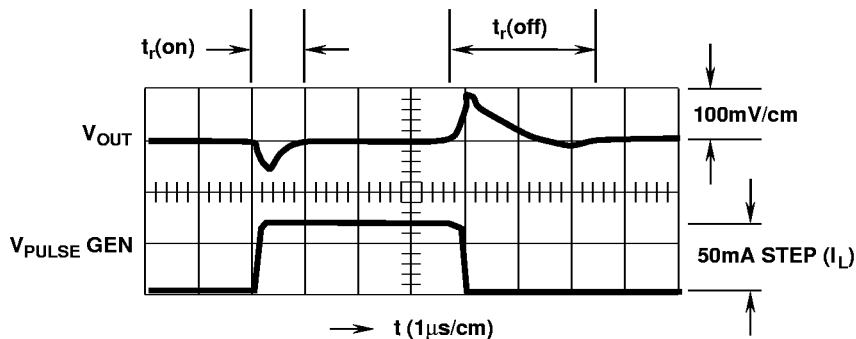
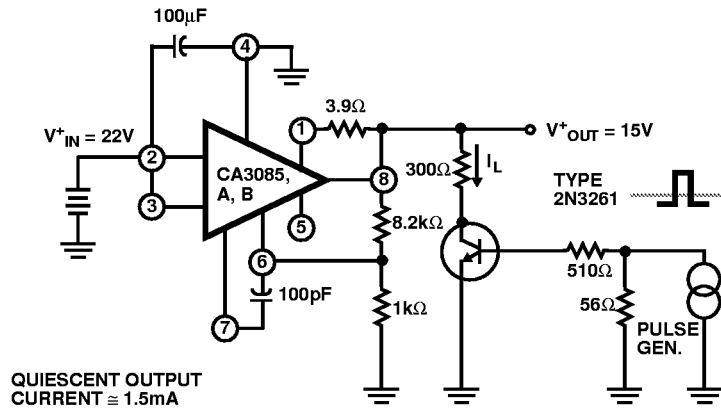

FIGURE 16. TURN-ON AND TURN-OFF RECOVERY TIME TEST CIRCUIT WITH ASSOCIATED WAVEFORMS

See Application Note AN6157 for further information

## CA3085, CA3085A, CA3085B

### Typical Regulator Circuits

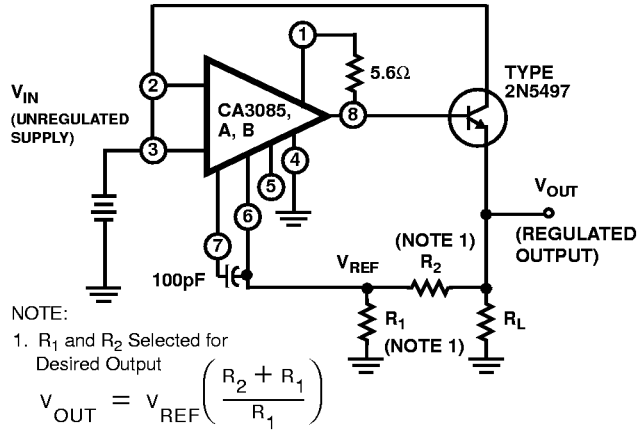
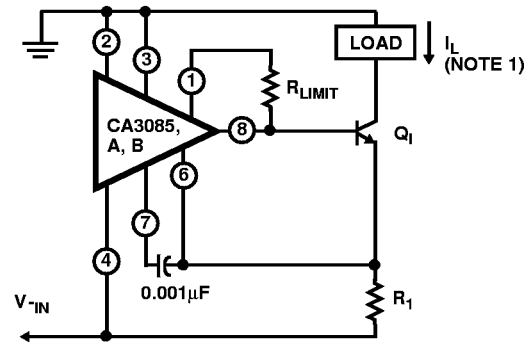

FIGURE 17. TYPICAL HIGH CURRENT VOLTAGE REGULATOR CIRCUIT



$Q_1$ : Any N-P-N Silicon Transistor that can handle a 2A Load Current such as 2N3772 or Equivalent

NOTE  
1.  $I_L = 1.6 \div R_1$ ,  $200\mu A \leq I_L \leq 2A$

FIGURE 18. TYPICAL CURRENT REGULATOR CIRCUIT

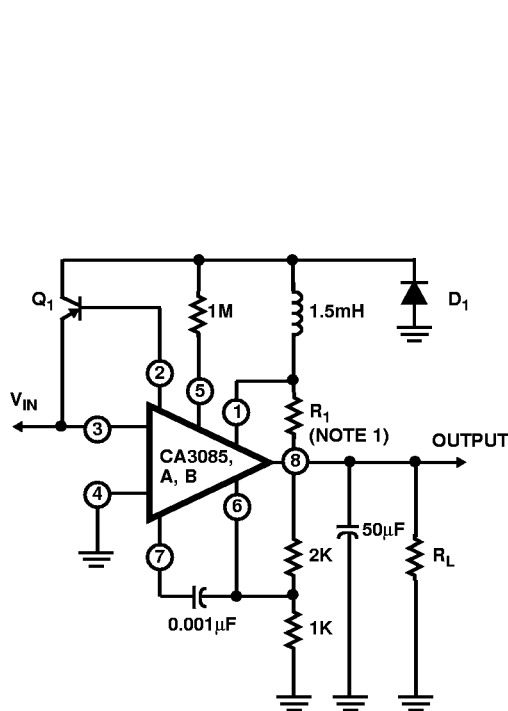

All Resistance Values are in Ohms  
 $D_1$ : 1N4001 or Equivalent  
 $Q_1$ : 2N5322 or Equivalent

NOTE:  
1.  $R_1 = 0.7 I_L$  (Max)

FIGURE 19. TYPICAL SWITCHING REGULATOR CIRCUIT

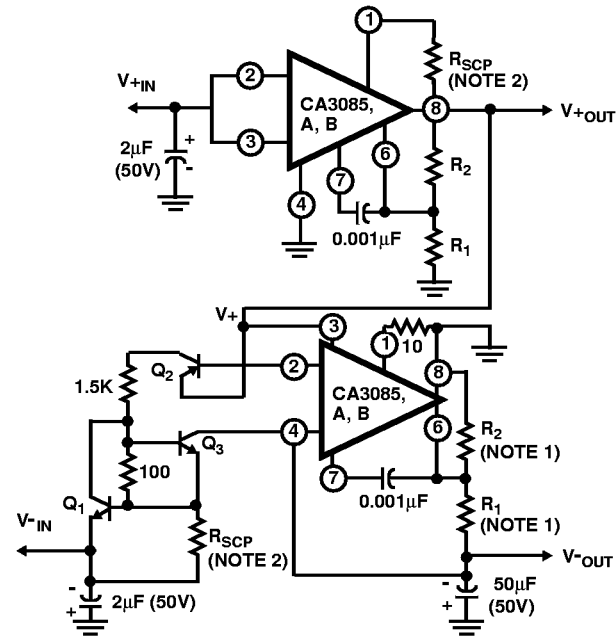

All Resistance Values are in Ohms  
 $Q_1$ : 2N2102 or Equivalent  
 $Q_2$ : Any P-N-P Silicon Transistor (2N5322 or Equivalent)  
 $Q_3$ : Any N-P-N Silicon Transistor that can handle the desired Load Current (2N3772 or Equivalent)

NOTE:  
1.  $V_{OUT} = (R_1 + R_2) \div R_1$   
2.  $R_{SCP}$ : Short Circuit Protection Resistance

FIGURE 20. COMBINATION POSITIVE AND NEGATIVE VOLTAGE REGULATOR CIRCUIT