

30MHz, High Output Current Operational Transconductance Amplifier (OTA)

The CA3094 is a differential input power control switch/amplifier with auxiliary circuit features for ease of programmability. For example, an error or unbalance signal can be amplified by the CA3094 to provide an on-off signal or proportional control output signal up to 100mA. This signal is sufficient to directly drive high current thyristors, relays, DC loads, or power transistors. The CA3094 has the generic characteristics of the CA3080 operational amplifier directly coupled to an integral Darlington power transistor capable of sinking or driving currents up to 100mA.

The gain of the differential input stage is proportional to the amplifier bias current (I_{ABC}), permitting programmable variation of the integrated circuit sensitivity with either digital and/or analog programming signals. For example, at an I_{ABC} of 100 μ A, a 1mV change at the input will change the output from 0 to 100 μ A (typical).

The CA3094 is intended for operation up to 24V and is especially useful for timing circuits, in automotive equipment, and in other applications where operation up to 24V is a primary design requirement (see Figures 28, 29 and 30 in Typical Applications text). The CA3094A and CA3094B are like the CA3094 but are intended for operation up to 36V and 44V, respectively (single or dual supply).

Ordering Information

PART NUMBER (BRAND)	TEMP. RANGE (°C)	PACKAGE	PKG. NO.
CA3094AT, BT	-55 to 125	8 Pin Metal Can	T8.C
CA3094E, AE	-55 to 125	8 Ld PDIP	E8.3
CA3094M, BM	-55 to 125	8 Ld SOIC	M8.15

Features

- CA3094E, M for Operation Up to 24V
- CA3094AT, E, M for Operation Up to 36V
- CA3094BT, M for Operation Up to 44V
- Designed for Single or Dual Power Supply
- Programmable: Strobing, Gating, Squelching, AGC Capabilities
- Can Deliver 3W (Average) or 10W (Peak) to External Load (in Switching Mode)
- High Power, Single Ended Class A Amplifier will Deliver Power Output of 0.6W (1.6W Device Dissipation)
- Total Harmonic Distortion (THD) at 0.6W in Class A Operation 1.4% (Typ)

Applications

- Error Signal Detector: Temperature Control with Thermistor Sensor; Speed Control for Shunt Wound DC Motor
- Over Current, Over Voltage, Over Temperature Protectors
- Dual Tracking Power Supply with CA3085
- Wide Frequency Range Oscillator
- Analog Timer
- Level Detector
- Alarm Systems
- Voltage Follower
- Ramp Voltage Generator
- High Power Comparator
- Ground Fault Interrupter (GFI) Circuits

Pinouts

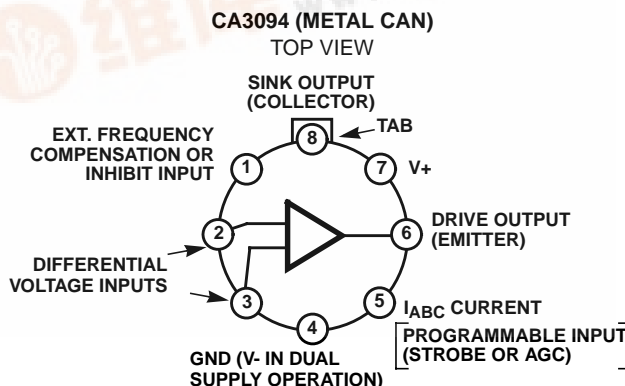
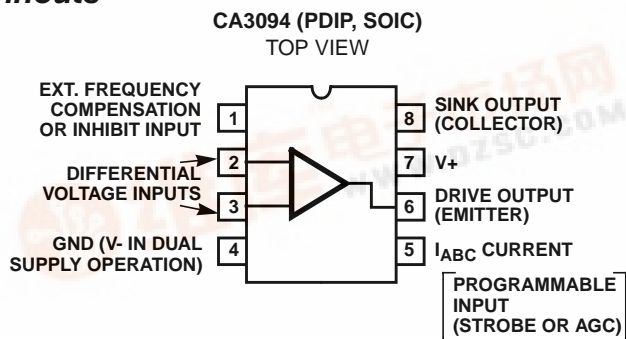

NOTE: Pin 4 is connected to case.



CA3094, CA3094A, CA3094B

Absolute Maximum Ratings

Supply Voltage (Between V+ and V- Terminals)	
CA3094	24V
CA3094A	36V
CA3094B	44V
Differential Input Voltage (Terminals 2 and 3, Note 1)	5V
DC Input Voltage	V+ to V-
Input Current (Terminals 2 and 3)	±1mA
Amplifier Bias Current (Terminal 5)	2mA
Average Output Current	100mA
Peak Output Current	300mA

Thermal Information

Thermal Resistance (Typical, Note 2)	θ_{JA} (°C/W)	θ_{JC} (°C/W)
PDIP Package	130	N/A
SOIC Package	170	N/A
Metal Can Package	175	100
Maximum Junction Temperature (Metal Can Package)	175°C	
Maximum Junction Temperature (Plastic Package)	150°C	
Maximum Storage Temperature Range	-65°C to 150°C	
Maximum Lead Temperature (Soldering 10s)	300°C (SOIC - Lead Tips Only)	

Operating Conditions

Temperature Range -55°C to 125°C

CAUTION: Stresses above those listed in "Absolute Maximum Ratings" may cause permanent damage to the device. This is a stress only rating and operation of the device at these or any other conditions above those indicated in the operational sections of this specification is not implied.

NOTES:

- Exceeding this voltage rating will not damage the device unless the peak input signal current (1mA) is also exceeded.
- θ_{JA} is measured with the component mounted on an evaluation PC board in free air.

Electrical Specifications $T_A = 25^\circ\text{C}$ for Equipment Design. Single Supply $V_+ = 30\text{V}$, Dual Supply $V_{\text{SUPPLY}} = \pm 15\text{V}$, $I_{\text{ABC}} = 100\mu\text{A}$ Unless Otherwise Specified

PARAMETER	SYMBOL	TEST CONDITIONS	MIN	TYP	MAX	UNITS
INPUT PARAMETERS						
Input Offset Voltage	V_{IO}	$T_A = 25^\circ\text{C}$	-	0.4	5.0	mV
		$T_A = 0^\circ\text{C}$ to 70°C	-	-	7.0	mV
Input Offset Voltage Change	$ \Delta V_{IO} $	Change in V_{IO} between $I_{\text{ABC}} = 100\mu\text{A}$ and $I_{\text{ABC}} = 5\mu\text{A}$	-	1	8.0	mV
Input Offset Current	I_{IO}	$T_A = 25^\circ\text{C}$	-	0.02	0.2	μA
		$T_A = 0^\circ\text{C}$ to 70°C	-	-	0.3	μA
Input Bias Current	I_I	$T_A = 25^\circ\text{C}$	-	0.2	0.50	μA
		$T_A = 0^\circ\text{C}$ to 70°C	-	-	0.70	μA
Device Dissipation	P_D	$I_{\text{OUT}} = 0\text{mA}$	8	10	12	mW
Common Mode Rejection Ratio	CMRR		70	110	-	dB
Common Mode Input Voltage Range	V_{ICR}	$V_+ = 30\text{V}$ (High)	27	28.8	-	V
		$V_- = 0\text{V}$ (Low)	1.0	0.5	-	V
		$V_+ = 15\text{V}$	12	13.8	-	V
		$V_- = -15\text{V}$	-14	-14.5	-	V
Unity Gain Bandwidth	f_T	$I_C = 7.5\text{mA}$, $V_{\text{CE}} = 15\text{V}$, $I_{\text{ABC}} = 500\mu\text{A}$	-	30	-	MHz
Open Loop Bandwidth at -3dB Point	BW_{OL}	$I_C = 7.5\text{mA}$, $V_{\text{CE}} = 15\text{V}$, $I_{\text{ABC}} = 500\mu\text{A}$	-	4	-	kHz
Total Harmonic Distortion (Class A Operation)	THD	$P_D = 220\text{mW}$	-	0.4	-	%
		$P_D = 600\text{mW}$	-	1.4	-	%
Amplifier Bias Voltage (Terminal 5 to Terminal 4)	V_{ABC}		-	0.68	-	V
Input Offset Voltage Temperature Coefficient	$\Delta V_{IO}/\Delta T$		-	4	-	$\mu\text{V}/^\circ\text{C}$
Power Supply Rejection	$\Delta V_{IO}/\Delta V$		-	15	150	$\mu\text{V}/\text{V}$
1/F Noise Voltage	E_N	$f = 10\text{Hz}$, $I_{\text{ABC}} = 50\mu\text{A}$	-	18	-	$\text{nV}/\sqrt{\text{Hz}}$
1/F Noise Current	I_N	$f = 10\text{Hz}$, $I_{\text{ABC}} = 50\mu\text{A}$	-	1.8	-	$\text{pA}/\sqrt{\text{Hz}}$
Differential Input Resistance	R_I	$I_{\text{ABC}} = 20\mu\text{A}$	0.50	1.0	-	$\text{M}\Omega$
Differential Input Capacitance	C_I	$f = 1\text{MHz}$, $V_+ = 30\text{V}$	-	2.6	-	pF

CA3094, CA3094A, CA3094B

Electrical Specifications $T_A = 25^\circ\text{C}$ for Equipment Design. Single Supply $V_+ = 30\text{V}$, Dual Supply $V_{\text{SUPPLY}} = \pm 15\text{V}$, $I_{\text{ABC}} = 100\mu\text{A}$ Unless Otherwise Specified **(Continued)**

PARAMETER		SYMBOL	TEST CONDITIONS	MIN	TYP	MAX	UNITS
OUTPUT PARAMETERS (Differential Input Voltage = 1V)							
Peak Output Voltage (Terminal 6)	With Q ₁₃ "ON"	$V_{\text{OM}+}$	$V_+ = 30\text{V}$, $R_L = 2\text{k}\Omega$ to GND	26	27	-	V
	With Q ₁₃ "OFF"	$V_{\text{OM}-}$		-	0.01	0.05	V
Peak Output Voltage (Terminal 6)	Positive	$V_{\text{OM}+}$	$V_+ = 15\text{V}$, $V_- = -15\text{V}$, $R_L = 2\text{k}\Omega$ to -15V	11	12	-	V
	Negative	$V_{\text{OM}-}$		-	-14.99	-14.95	V
Peak Output Voltage (Terminal 8)	With Q ₁₃ "OFF"	$V_{\text{OM}+}$	$V_+ = 30\text{V}$, $R_L = 2\text{k}\Omega$ to 30V	29.95	29.99	-	V
	With Q ₁₃ "ON"	$V_{\text{OM}-}$		-	0.040	-	V
Peak Output Voltage (Terminal 8)	Positive	$V_{\text{OM}+}$	$V_+ = 15\text{V}$, $V_- = -15\text{V}$, $R_L = 2\text{k}\Omega$ to 15V	14.95	14.99	-	V
	Negative	$V_{\text{OM}-}$		-	-14.96	-	V
Collector-to-Emitter Saturation Voltage (Terminal 8)		$V_{\text{CE(SAT)}}$	$V_+ = 30\text{V}$, $I_C = 50\text{mA}$, Terminal 6 Grounded	-	0.17	0.80	V
Output Leakage Current (Terminal 6 to Terminal 4)			$V_+ = 30\text{V}$	-	2	10	μA
Composite Small Signal Current Transfer Ratio (Beta) (Q ₁₂ and Q ₁₃)		h_{FE}	$V_+ = 30\text{V}$, $V_{\text{CE}} = 5\text{V}$, $I_C = 50\text{mA}$	16,000	100,000	-	
Output Capacitance	Terminal 6	C_O	$f = 1\text{MHz}$, All Remaining Terminals Tied to Terminal 4	-	5.5	-	pF
	Terminal 8			-	17	-	pF
TRANSFER PARAMETERS							
Voltage Gain		A	$V_+ = 30\text{V}$, $I_{\text{ABC}} = 100\mu\text{A}$, $\Delta V_{\text{OUT}} = 20\text{V}$, $R_L = 2\text{k}\Omega$	20,000	100,000	-	V/V
				86	100	-	dB
Forward Transconductance to Terminal 1		g_M		1650	2200	2750	μS
Slew Rate (Open Loop)	Positive Slope	SR	$I_{\text{ABC}} = 500\mu\text{A}$, $R_L = 2\text{k}\Omega$	-	500	-	V/ μs
	Negative Slope			-	50	-	V/ μs
Unity Gain (Non-Inverting Compensated)			$I_{\text{ABC}} = 500\mu\text{A}$, $R_L = 2\text{k}\Omega$	-	0.70	-	V/ μs

Schematic Diagram

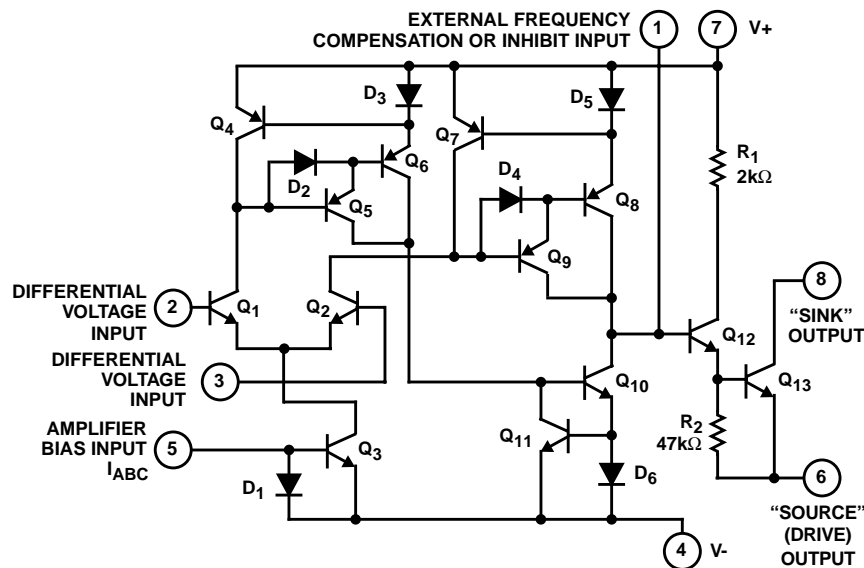

OUTPUT MODE	OUTPUT TERM	INPUTS	
		INV	NON-INV
"Source"	6	2	3
"Sink"	8	3	2

CA3094, CA3094A, CA3094B

Operating Considerations

The “Sink” Output (Terminal 8) and the “Drive” Output (Terminal 6) of the CA3094 are not inherently current (or power) limited. Therefore, if a load is connected between Terminal 6 and Terminal 4 (V- or Ground), it is important to connect a current limiting resistor between Terminal 8 and Terminal 7 (V+) to protect transistor Q13 under shorted load conditions. Similarly, if a load is connected between Terminal 8 and Terminal 7 (V+), the current limiting resistor should be connected between Terminal 6 and Terminal 4 or ground. In circuit applications where the emitter of the output transistor is not connected to the most negative potential in the system, it is recommended that a 100Ω current limiting resistor be inserted between Terminal 7 and the V+ supply.

1/f Noise Measurement Circuit

When using the CA3094, A, or B audio amplifier circuits, it is frequently necessary to consider the noise performance of the device. Noise measurements are made in the circuit shown in Figure 20. This circuit is a 30dB, non-inverting amplifier with emitter follower output and phase compensation from Terminal 2 to ground. Source resistors (R_S) are set to 0Ω or 1MΩ for E noise and I noise measurements, respectively. These measurements are made at frequencies of 10Hz, 100Hz and 1kHz with a 1Hz measurement bandwidth. Typical values for 1/f noise at 10Hz and 50μA I_{ABC} are:

$$E_N = 18\text{nV}/\sqrt{\text{Hz}} \quad \text{and} \quad I_N = 1.8\text{pA}/\sqrt{\text{Hz}} .$$

Test Circuits

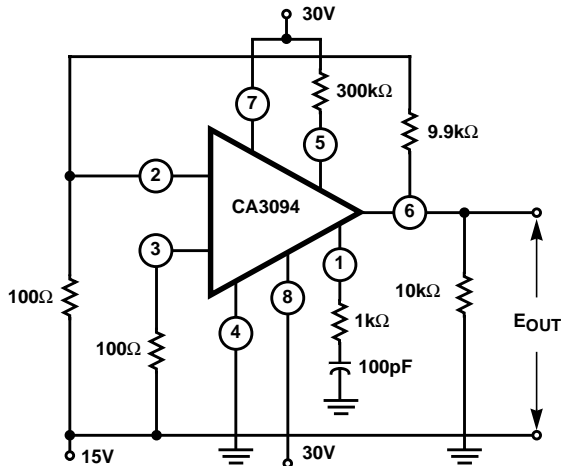

FIGURE 1. INPUT OFFSET VOLTAGE AND POWER SUPPLY REJECTION TEST CIRCUIT

NOTES:

3. Input Offset Voltage: $V_{IO} = \frac{E_{OUT}}{100}$.
4. For Power Supply Rejection Test: (1) vary V+ by -2V; then (2) vary V- by +2V.

5. Equations:

$$(1) \text{ V+ Rejection} = \frac{E_0\text{OUT} - E_1\text{OUT}}{200}$$

$$(2) \text{ V- Rejection} = \frac{E_0\text{OUT} - E_2\text{OUT}}{200}$$

$$6. \text{ Power Supply Rejection: (dB)} = 20\log \frac{1}{\text{REJECTION}^\dagger} .$$

† Maximum Reading of Step 1 or Step 2

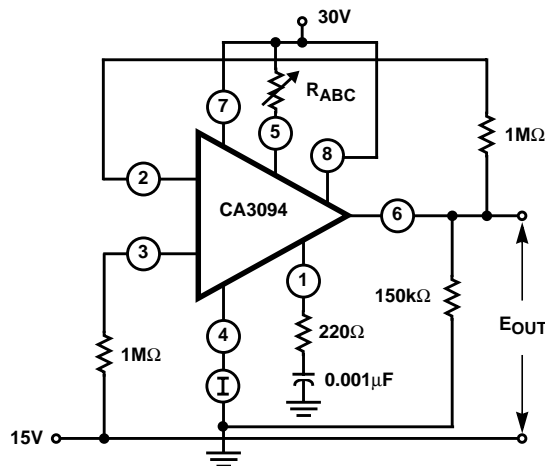

NOTES:

7. $P_{DISSIPATION} = (V+)(I)$
8. $I_{OS} = \frac{E_{OUT}}{10^6 \frac{\text{VOLTS}}{\text{AMPS}}}$

FIGURE 2. INPUT OFFSET CURRENT TEST CIRCUIT

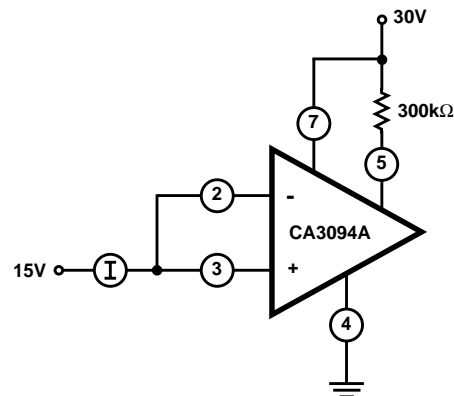

$$\text{NOTE: } I_1 = \frac{I}{2}$$

FIGURE 3. INPUT BIAS CURRENT TEST CIRCUIT

CA3094, CA3094A, CA3094B

Test Circuits (Continued)

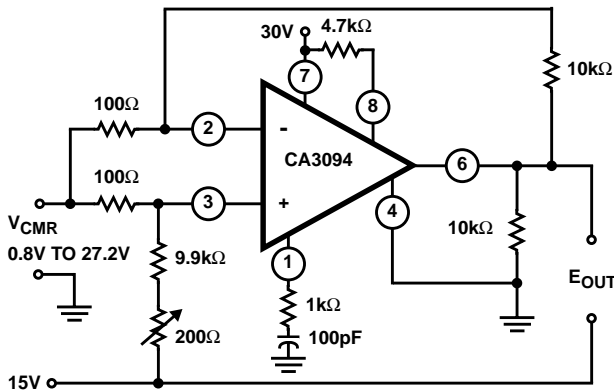

FIGURE 4. COMMON MODE RANGE AND REJECTION RATIO TEST CIRCUIT

NOTES:

9. $CMRR = \left| \frac{100 \times 26V}{E_{2OUT} - E_{1OUT}} \right|$.
10. Input Voltage Range for CMRR = 1V to 27V.
11. $CMRR (dB) = 20 \log \left| \frac{100 \times 26V}{E_{2OUT} - E_{1OUT}} \right|$.

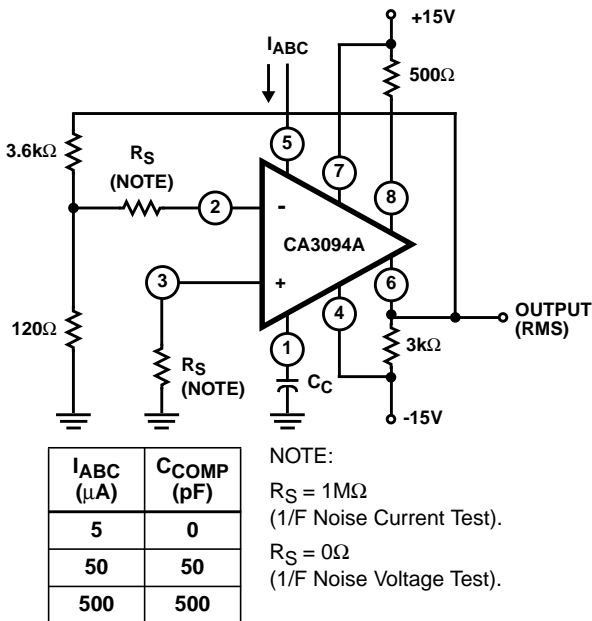

FIGURE 5. 1/F NOISE TEST CIRCUIT

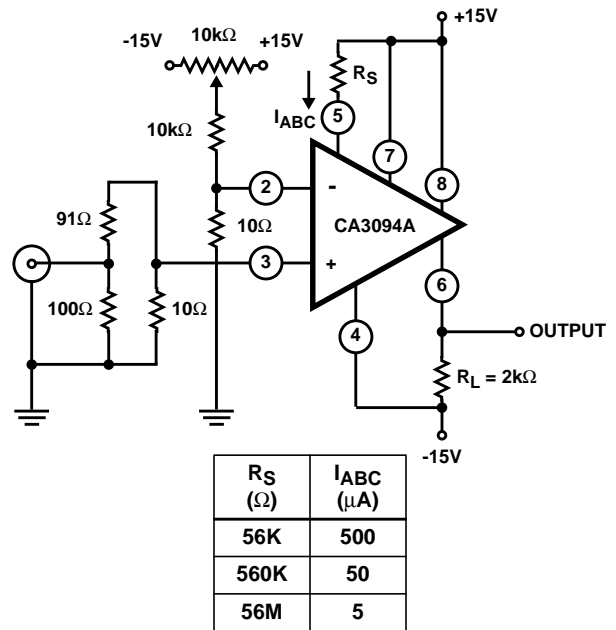

FIGURE 6. OPEN LOOP GAIN vs FREQUENCY TEST CIRCUIT

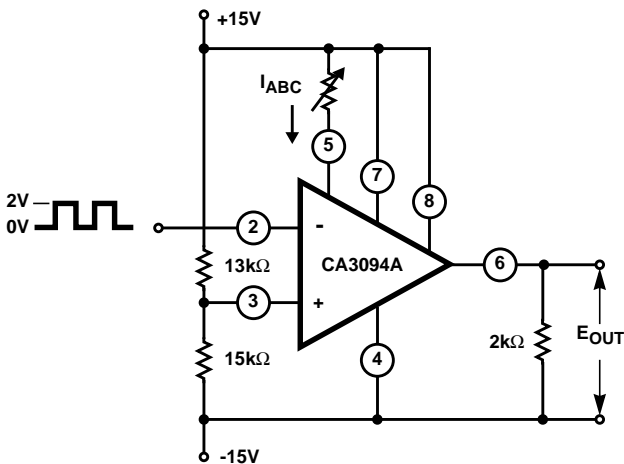

FIGURE 7. OPEN LOOP SLEW RATE vs I_{ABC} TEST CIRCUIT

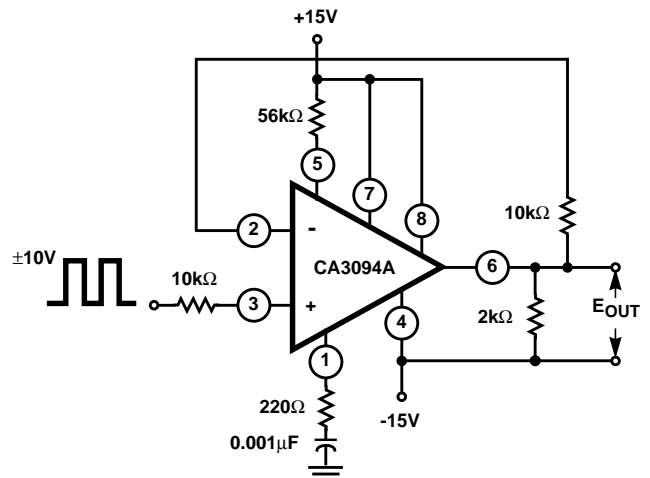

FIGURE 8. SLEW RATE vs NON-INVERTING UNITY GAIN TEST CIRCUIT

CA3094, CA3094A, CA3094B

Typical Applications

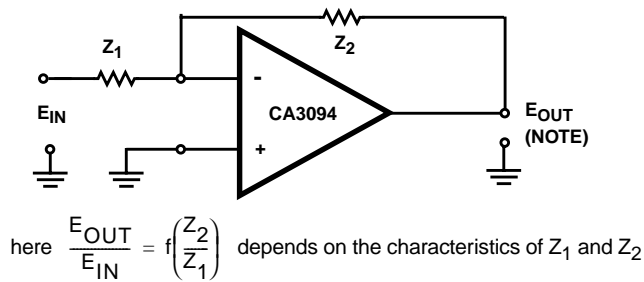

FIGURE 11A. INVERTING OP AMP

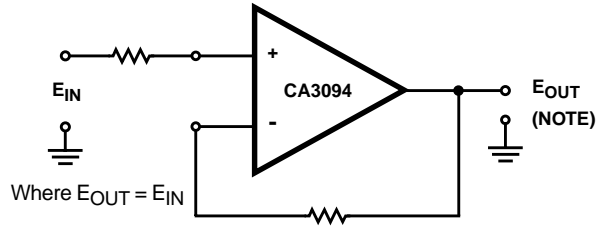
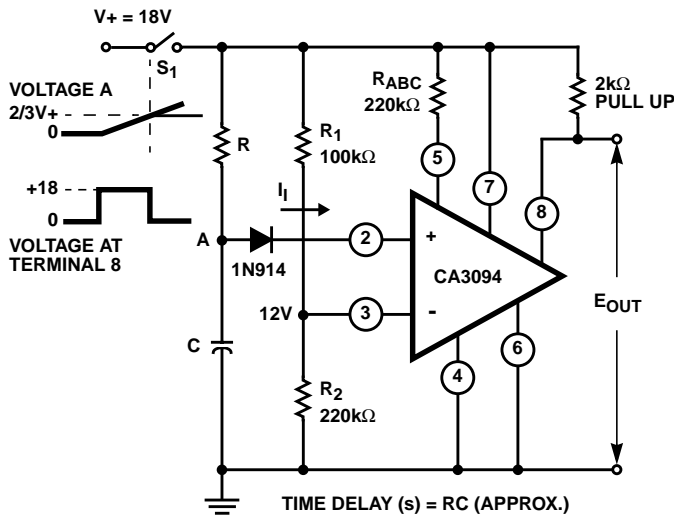

FIGURE 11B. NON-INVERTING MODE, AS A FOLLOWER

FIGURE 11. APPLICATION OF THE CA3094



Problem: To calculate the maximum value of R required to switch a 100mA output current comparator

Given: $I_{ABC} = 5\mu A$, $R_{ABC} = 3.6M\Omega \approx \frac{18V}{5\mu A}$

$I_1 = 500nA$ at $I_{ABC} = 100\mu A$ (from Figure 3)

$I_1 = 5\mu A$ can be determined by drawing a line on Figure 3 through $I_{ABC} = 100\mu A$ and $I_B = 500nA$ parallel to the typical $T_A = 25^\circ C$ curve.

Then: $I_1 = 33nA$ at $I_{ABC} = 5\mu A$

$R_{MAX} = \frac{18V - 12V}{33nA} = 180M\Omega$ at $T_A = 25^\circ C$

$R_{MAX} = 180M\Omega \times 2/3^\dagger = 120M\Omega$ at $T_A = -55^\circ C$

† Ratio of I_1 at $T_A = 25^\circ C$ to I_1 at $T_A = -55^\circ C$ for any given value of I_{ABC}

FIGURE 12. RC TIMER

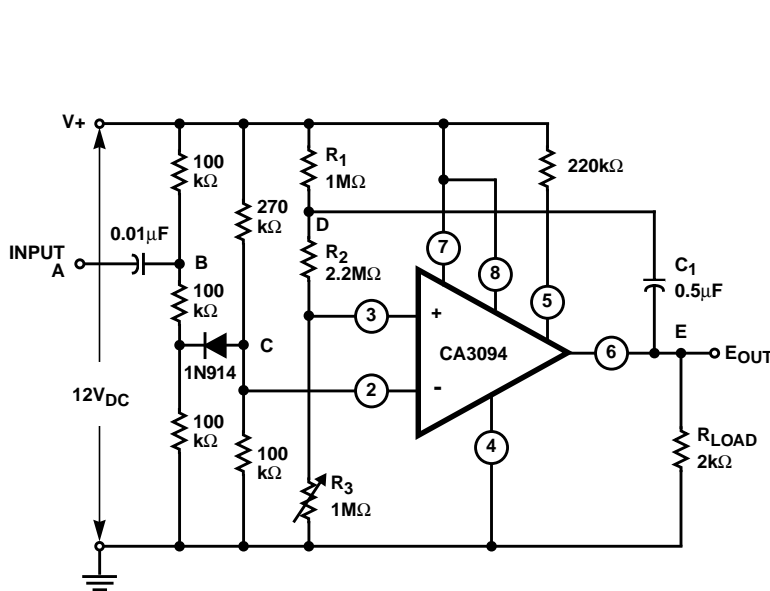
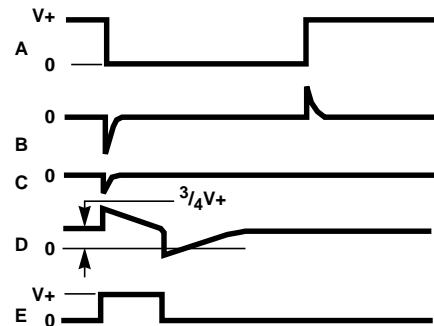

FIGURE 13. RC TIMER TRIGGERED BY EXTERNAL NEGATIVE PULSE



On a negative going transient at input (A), a negative pulse at C will turn "on" the CA3094, and the output (E) will go from a low to a high level.

At the end of the time constant determined by C_1 , R_1 , R_2 , R_3 , the CA3094 will return to the "off" state and the output will be pulled low by R_{LOAD} . This condition will be independent of the interval when input (A) returns to a high level.

CA3094, CA3094A, CA3094B

Typical Applications (Continued)

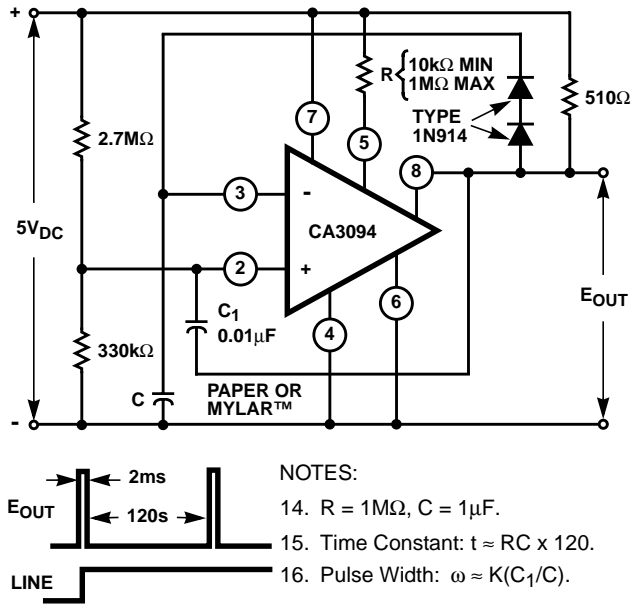

FIGURE 14. FREE RUNNING PULSE GENERATOR

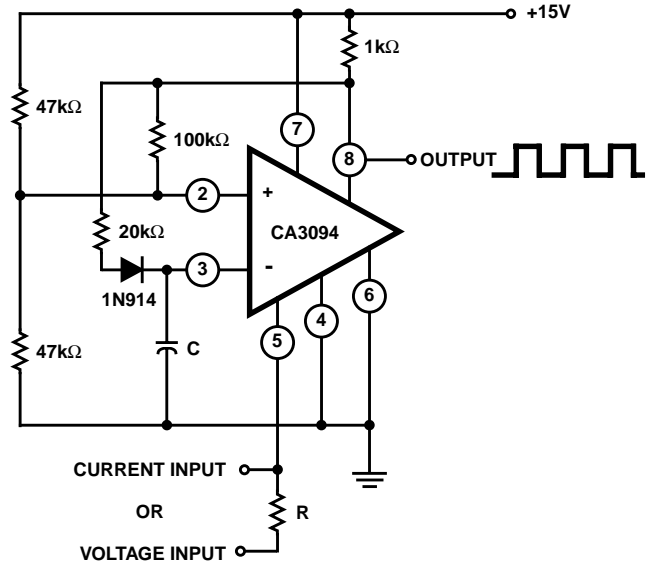

FIGURE 15. CURRENT OR VOLTAGE CONTROLLED OSCILLATOR

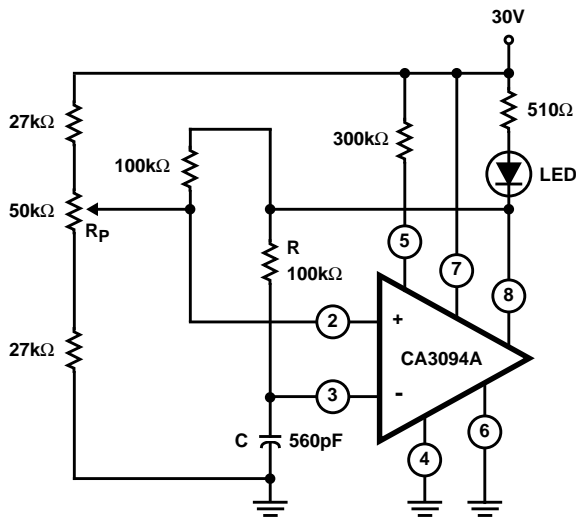
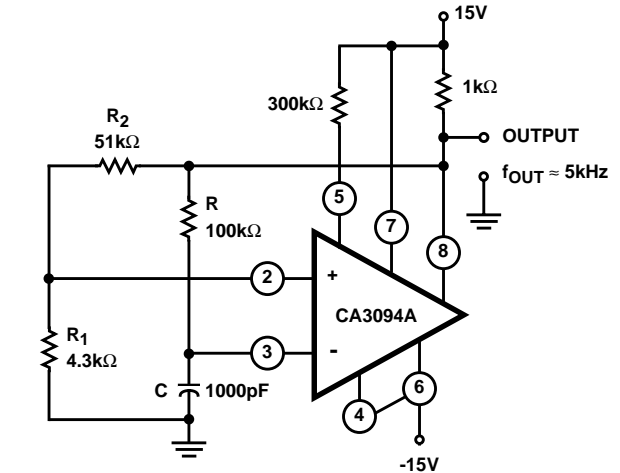

FIGURE 16. SINGLE SUPPLY ASTABLE MULTIVIBRATOR



$$\text{NOTE: } f_{\text{OUT}} = \frac{1}{(2RC) \ln\left(\frac{2R_1}{R_2} + 1\right)}$$

$$\text{If: } R_2 = 3.08R_1, f_{\text{OUT}} = \frac{1}{RC}$$

FIGURE 17. DUAL SUPPLY ASTABLE MULTIVIBRATOR

CA3094, CA3094A, CA3094B

Typical Applications (Continued)

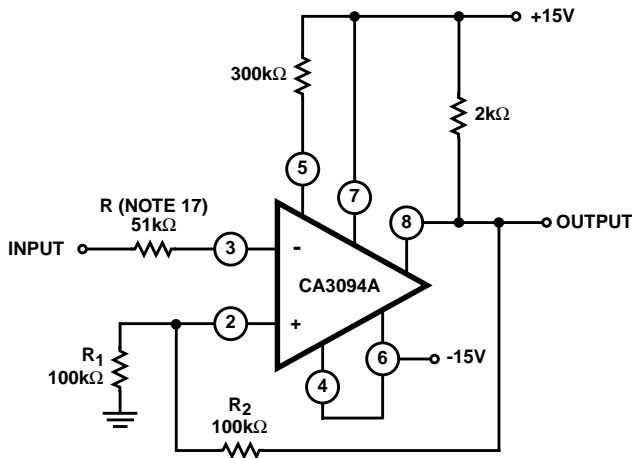

NOTES:

17. $R = \frac{R_1 R_2}{R_1 + R_2}$.

18. $\pm\text{Threshold} = [\pm\text{Supply}] \left[\frac{R_1}{R_1 + R_2} \right]$.

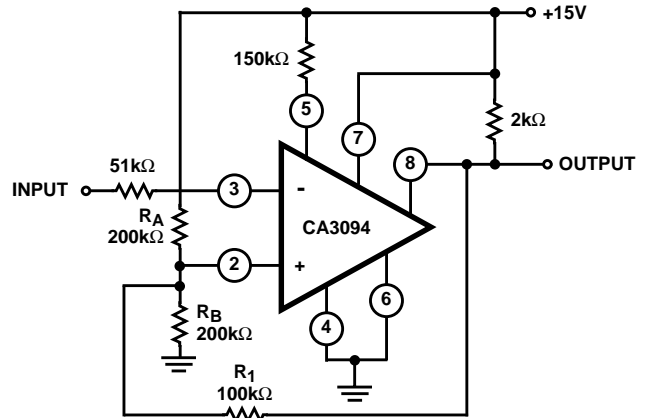

NOTES:

19. Upper Threshold = $[V+] \left[\frac{R_B}{\left(\frac{R_1 R_A}{R_1 + R_A} \right) + R_B} \right]$.

20. Lower Threshold = $[V+] \left[\frac{\frac{R_1 R_B}{R_1 + R_B}}{\left(\frac{R_1 R_B}{R_1 + R_B} \right) + R_A} \right]$.

FIGURE 18A. DUAL SUPPLY

FIGURE 18B. SINGLE SUPPLY

FIGURE 18. COMPARATORS (THRESHOLD DETECTORS) DUAL AND SINGLE SUPPLY TYPES

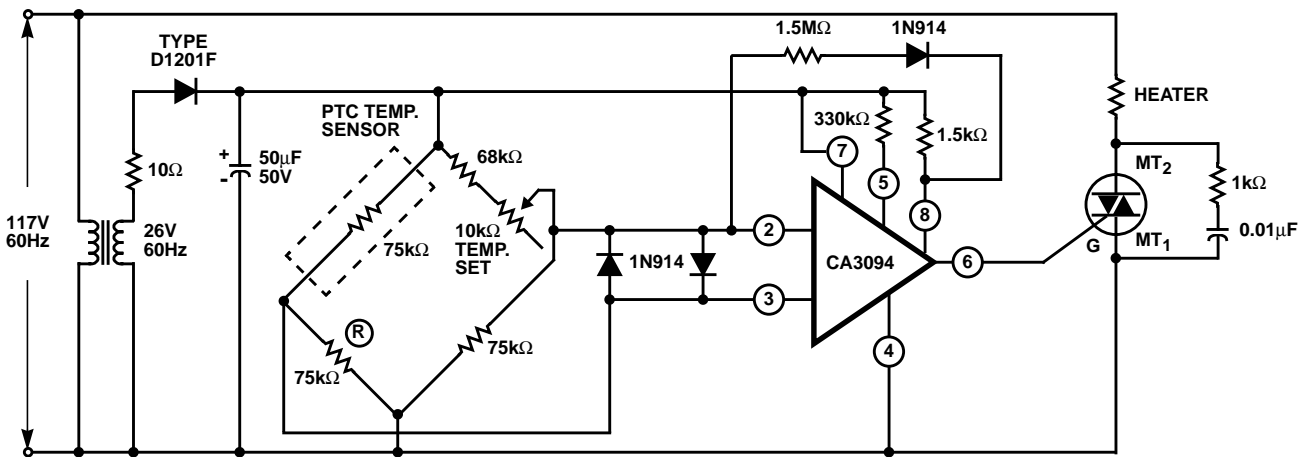

FOR NTC SENSOR, INTERCHANGE POSITION OF SENSOR AND (R).

NOTE: All Resistors are 1/2W.

FIGURE 19. TEMPERATURE CONTROLLER

CA3094, CA3094A, CA3094B

Typical Applications (Continued)

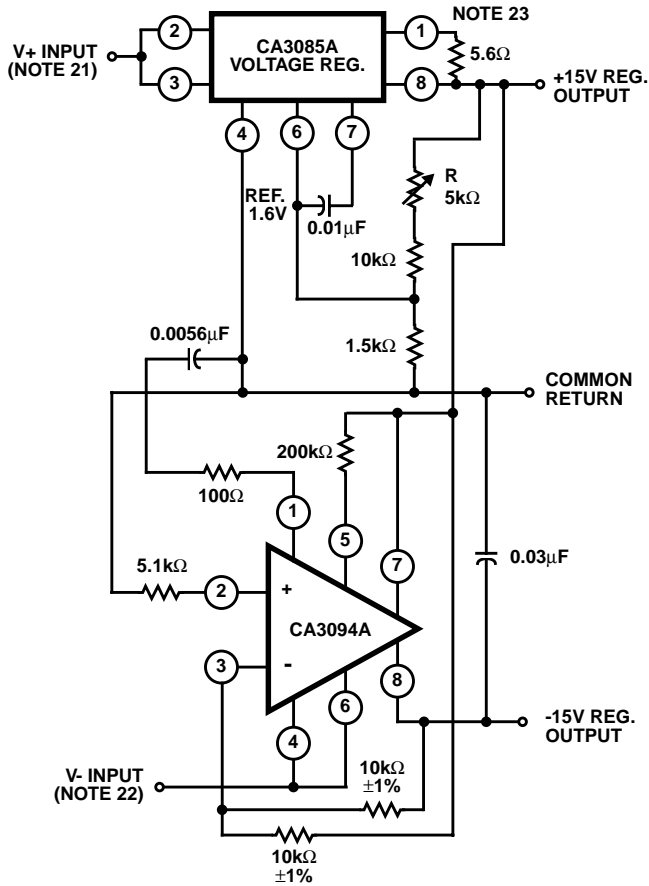

FIGURE 20. DUAL VOLTAGE TRACKING REGULATOR

NOTES:

- 21. V+ Input Range = 19V to 30V for 15V output.
- 22. V- Input Range = -16V to -30V for -15V output.
- 23. Max I_{OUT} = ±100mA.
- 24. Regulation:

$$\text{Max Line} = \frac{\Delta V_{\text{OUT}}}{[V_{\text{OUT}}(\text{Initial})]\Delta V_{\text{IN}}} \times 100 = 0.075\% / V$$

$$\text{Max Load} = \frac{\Delta V_{\text{OUT}}}{V_{\text{OUT}}(\text{Initial})} \times 100 = 0.075\% V_{\text{OUT}} \quad (I_L \text{ from } 1\text{mA to } 50\text{mA})$$

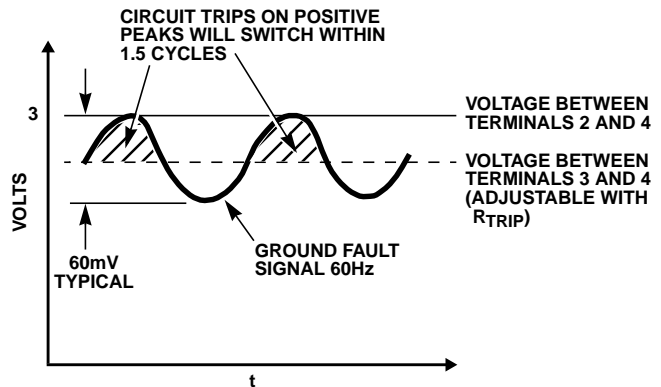
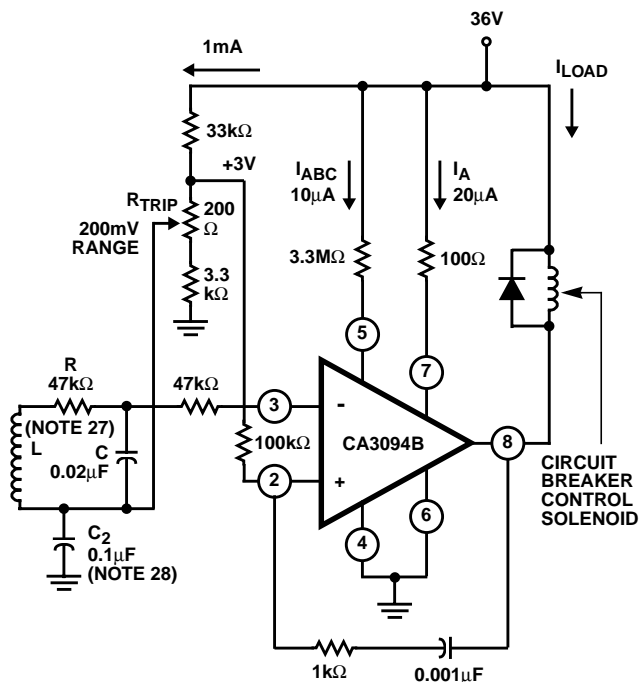

NOTES:

- 25. Differential current sensor provides 60mV signal ≈ 5mA of unbalance (Trip) current.
- 26. All Resistors are 1/2 Watt, ±10%.
- 27. RC selected for 3dB point at 200Hz.
- 28. C₂ = AC bypass.
- 29. Offset adj. included in R_{TRIP}.
- 30. Input impedance from 2 to 3 = 800kΩ.
- 31. With no input signal Terminal 8 (output) at 36V.

FIGURE 21. GROUND FAULT INTERRUPTER (GFI) AND WAVEFORMS PERTINENT TO GROUND FAULT DETECTOR

CA3094, CA3094A, CA3094B

Typical Applications (Continued)

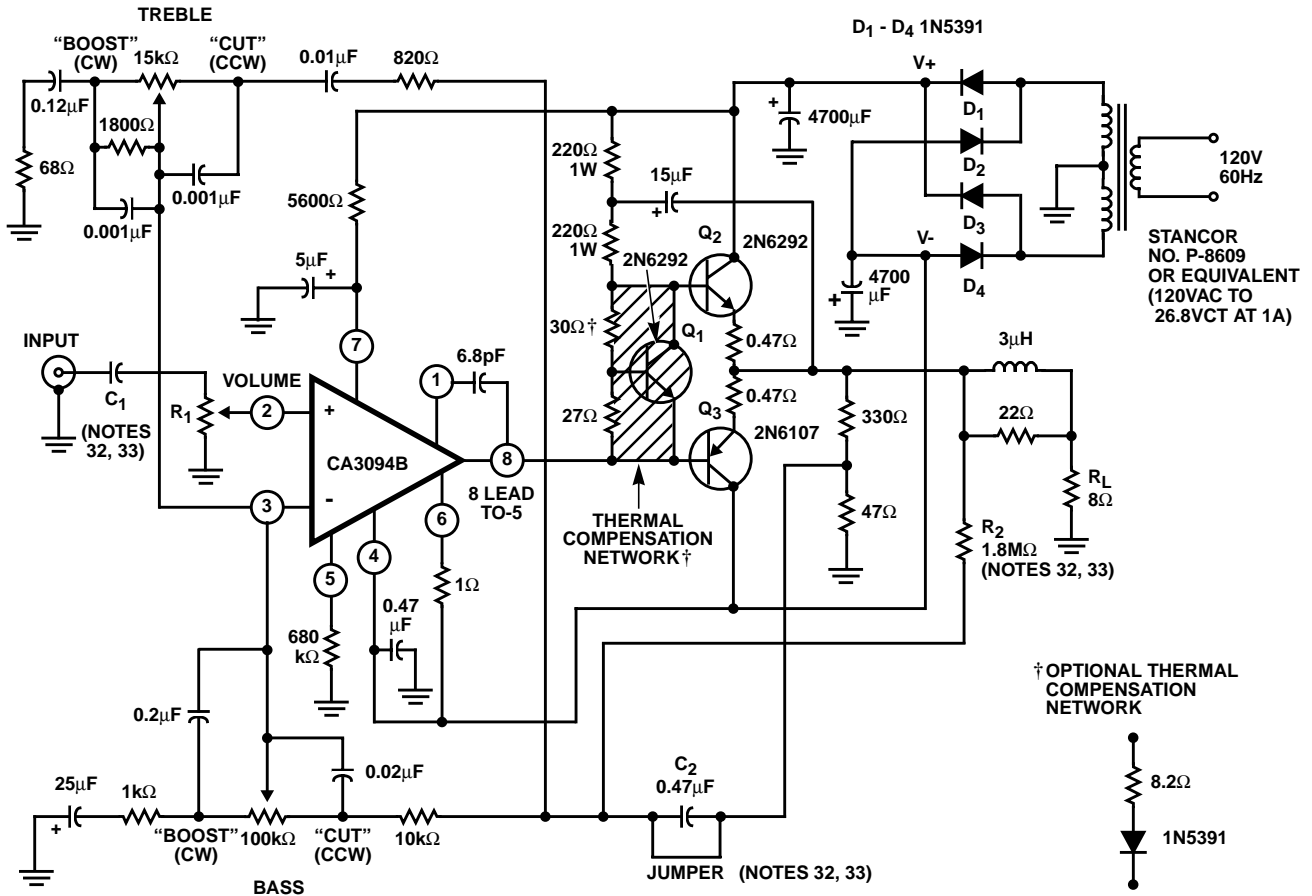

TYPICAL PERFORMANCE DATA FOR 12W AUDIO AMPLIFIER CIRCUIT

Power Output (8Ω load, Tone Control Set at "Flat")	
Music (at 5% THD, Regulated Supply)	15W
Continuous (at 0.2% IMD, 60Hz and 2kHz	
Mixed in a 4:1 Ratio, Unregulated Supply)	
See Figure 8 in AN6048	12W
Total Harmonic Distortion	
At 1W, Unregulated Supply	0.05%
At 12W, Unregulated Supply	0.57%
Voltage Gain	.40dB
Hum and Noise (Below Continuous Power Output)	.83dB

Input Resistance	250kΩ
Tone Control Range	See Figure 9 in AN6048

NOTES:

32. For standard input: Short C₂; R₁ = 250kΩ, C₁ = 0.047μF; remove R₂.
33. For ceramic cartridge input: C₁ = 0.0047μF, R₁ = 2.5MΩ, remove jumper from C₂; leave R₂.

FIGURE 22. 12W AUDIO AMPLIFIER CIRCUIT FEATURING TRUE COMPLEMENTARY SYMMETRY OUTPUT STAGE WITH CA3094 IN DRIVER STAGE

Typical Performance Curves

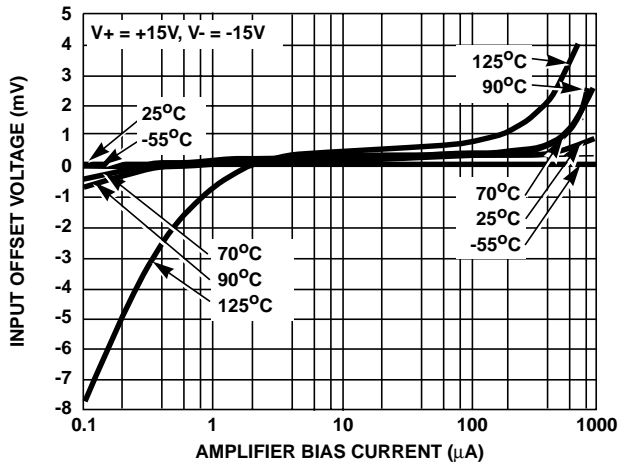

FIGURE 23. INPUT OFFSET VOLTAGE vs AMPLIFIER BIAS CURRENT (I_{ABC} , TERMINAL 5)

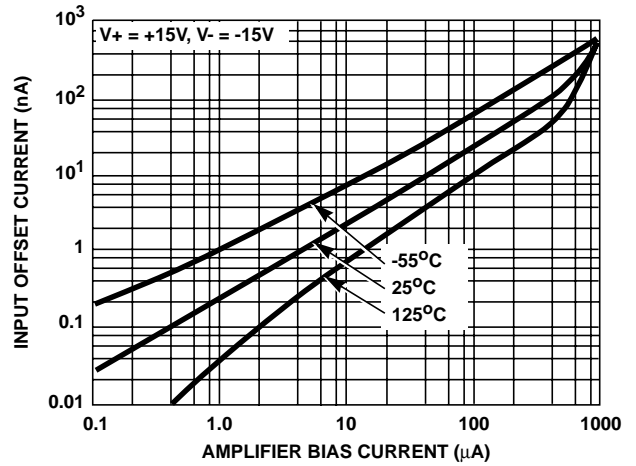

FIGURE 24. INPUT OFFSET CURRENT vs AMPLIFIER BIAS CURRENT (I_{ABC} , TERMINAL 5)

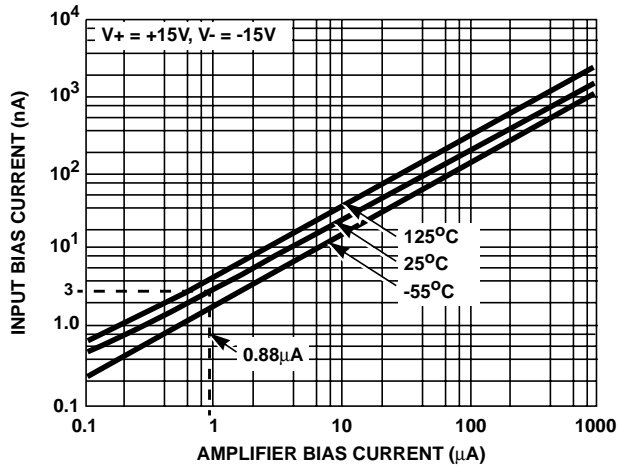

FIGURE 25. INPUT BIAS CURRENT vs AMPLIFIER BIAS CURRENT (I_{ABC} , TERMINAL 5)

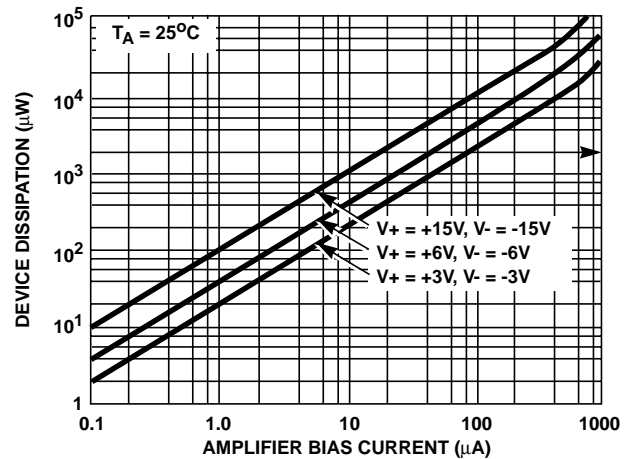

FIGURE 26. DEVICE DISSIPATION vs AMPLIFIER BIAS CURRENT (I_{ABC} , TERMINAL 5)

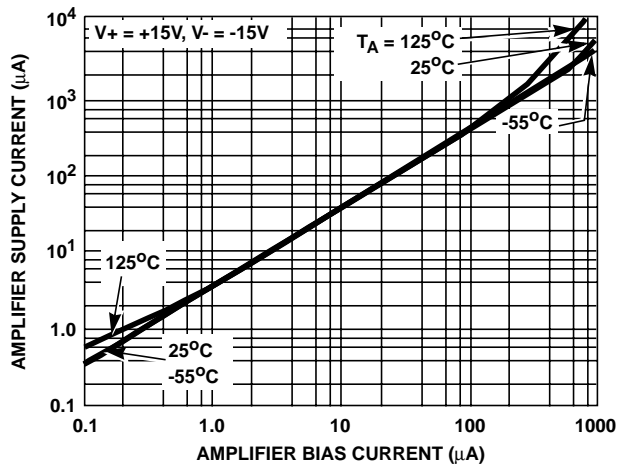

FIGURE 27. AMPLIFIER SUPPLY CURRENT vs AMPLIFIER BIAS CURRENT (I_{ABC} , TERMINAL 5)

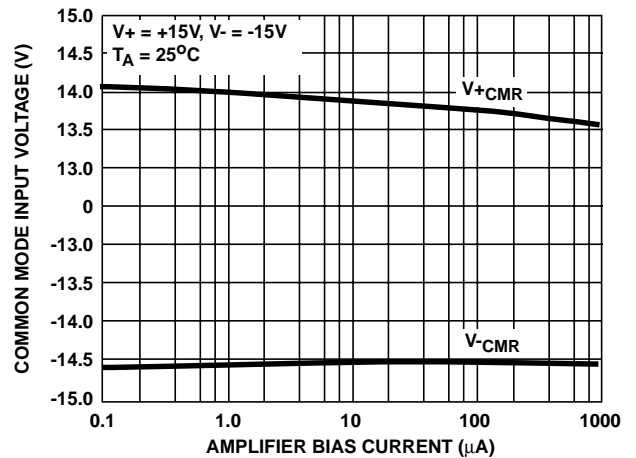

FIGURE 28. COMMON MODE INPUT VOLTAGE vs AMPLIFIER BIAS CURRENT (I_{ABC} , TERMINAL 5)

CA3094, CA3094A, CA3094B

Typical Performance Curves (Continued)

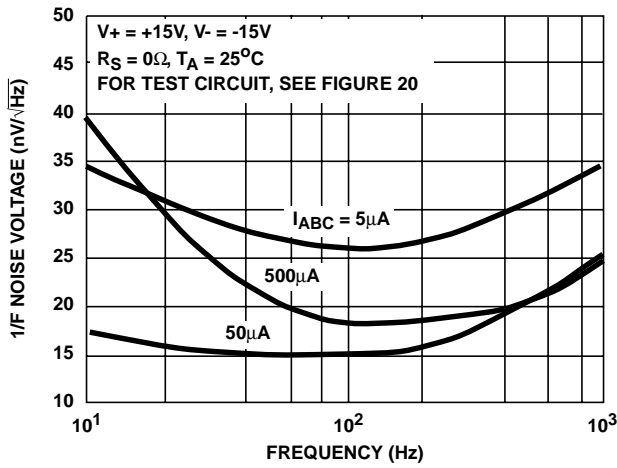

FIGURE 29. 1/f NOISE VOLTAGE vs FREQUENCY

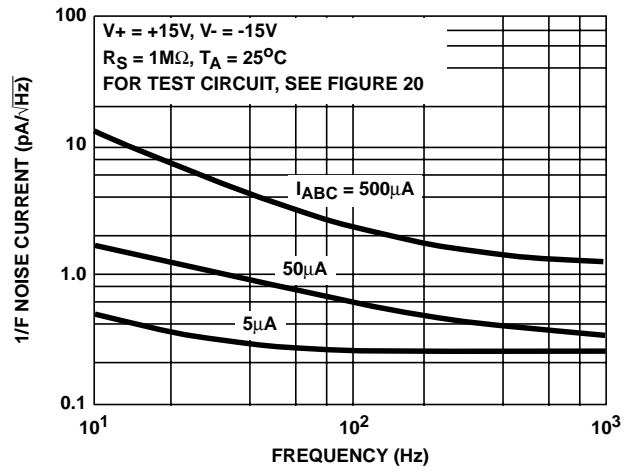

FIGURE 30. 1/f NOISE CURRENT vs FREQUENCY

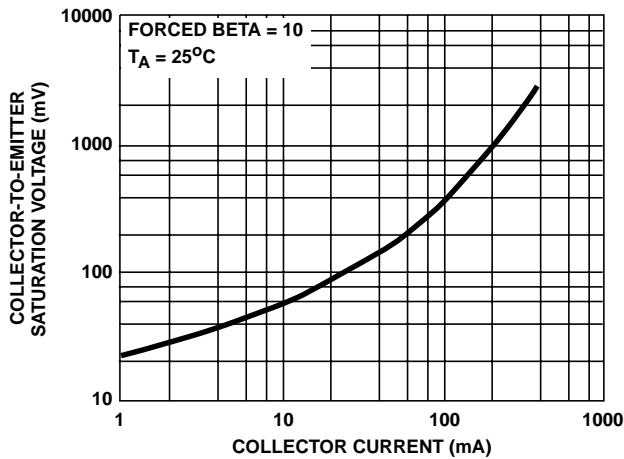

FIGURE 31. COLLECTOR-EMITTER SATURATION VOLTAGE vs COLLECTOR CURRENT OF OUTPUT TRANSISTOR (Q₁₃)

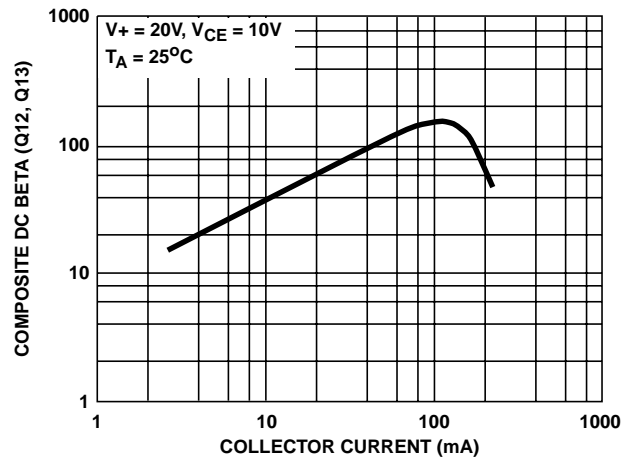

FIGURE 32. COMPOSITE DC BETA vs COLLECTOR CURRENT OF DARLINGTON CONNECTED OUTPUT TRANSISTORS (Q₁₂, Q₁₃)

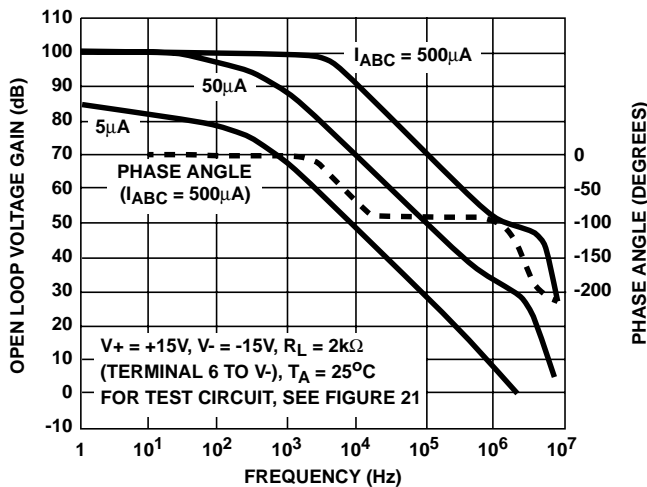

FIGURE 33. OPEN LOOP VOLTAGE GAIN vs FREQUENCY

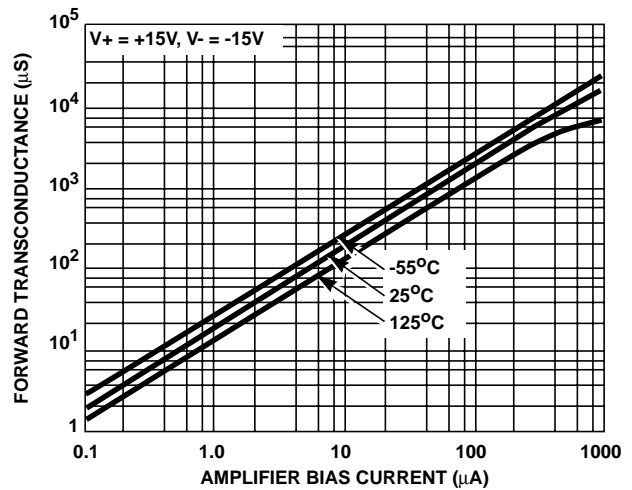

FIGURE 34. FORWARD TRANSCONDUCTANCE vs AMPLIFIER BIAS CURRENT

CA3094, CA3094A, CA3094B

Typical Performance Curves (Continued)

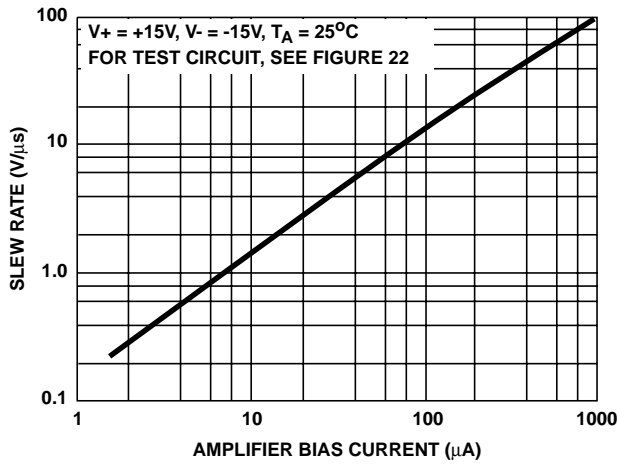

FIGURE 35. SLEW RATE vs AMPLIFIER BIAS CURRENT

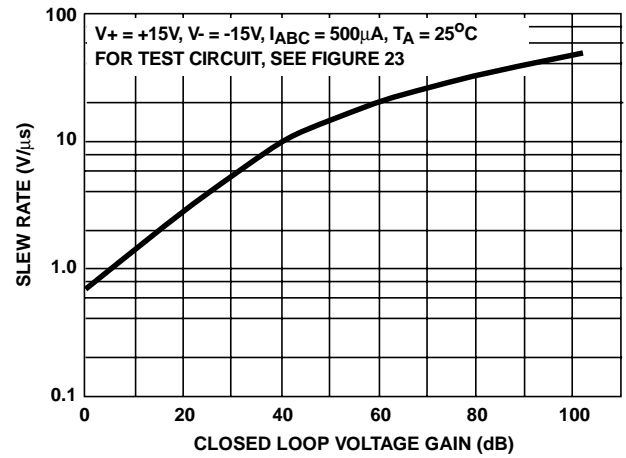

FIGURE 36. SLEW RATE vs CLOSED LOOP VOLTAGE GAIN

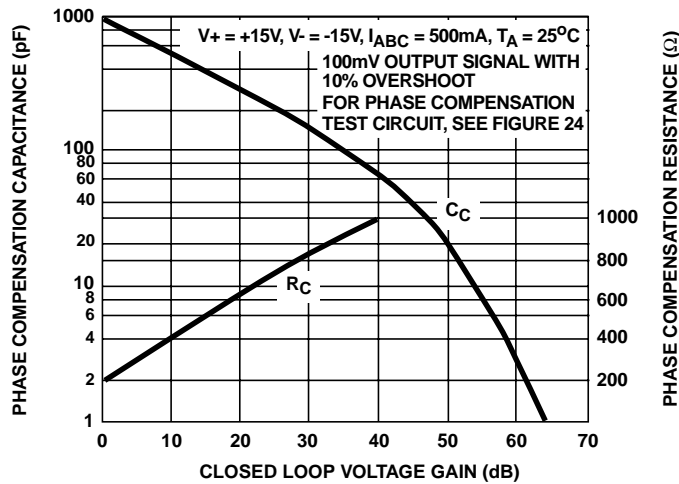

FIGURE 37. PHASE COMPENSATION CAPACITANCE AND RESISTANCE vs CLOSED LOOP VOLTAGE GAIN