

0.5MHz, Low Supply Voltage, Low Input Current BiMOS Operational Amplifiers

The CA5420A is an integrated circuit operational amplifier that combines PMOS transistors and bipolar transistors on a single monolithic chip. It is designed and guaranteed to operate in microprocessor logic systems that use $V_+ = 5V$, $V_- = GND$, since it can operate down to $\pm 1V$ supplies. It will also be suitable for 3.3V logic systems.

The CA5420A BiMOS operational amplifier features gate-protected PMOS transistors in the input circuit to provide very high input impedance, very low input currents (less than 1pA). The internal bootstrapping network features a unique guardbanding technique for reducing the doubling of leakage current for every $10^\circ C$ increase in temperature. The CA5420A operates at total supply voltages from 2V to 20V either single or dual supply. This operational amplifier is internally phase compensated to achieve stable operation in the unity gain follower configuration. Additionally, it has access terminals for a supplementary external capacitor if additional frequency roll-off is desired. Terminals are also provided for use in applications requiring input offset voltage nulling. The use of PMOS in the input stage results in common-mode input voltage capability down to 0.45V below the negative supply terminal, an important attribute for single supply application. The output stage uses a feedback OTA type amplifier that can swing essentially from rail-to-rail. The output driving current of 1.0mA (Min) is provided by using nonlinear current mirrors.

This device has guaranteed specifications for 5V operation over the full military temperature range of $-55^\circ C$ to $125^\circ C$.

The CA5420A has the same 8 lead pinout used for the industry standard 741.

Functional Diagram

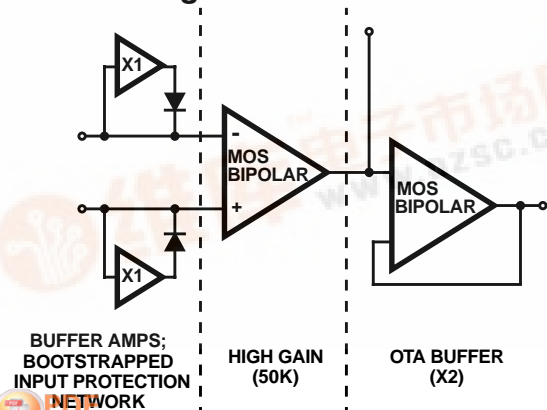

Features

- CA5420A at 5V Supply Voltage with Full Military Temperature Range Guaranteed Specifications
- CA5420A Guaranteed to Operate from $\pm 1V$ to $\pm 10V$ Supplies
- 2V Supply at 300 μA Supply Current
- 1pA (Typ) Input Current (Essentially Constant to $85^\circ C$)
- Rail-to-Rail Output Swing (Drive $\pm 2mA$ Into 1k Ω Load)
- Pin Compatible with 741 Op Amp

Applications

- pH Probe Amplifiers
- Picoammeters
- Electrometer (High Z) Instruments
- Portable Equipment
- Inaccessible Field Equipment
- Battery Dependent Equipment (Medical and Military)
- 5V Logic Systems
- Microprocessor Interface

Ordering Information

PART NUMBER (BRAND)	TEMP. RANGE ($^\circ C$)	PACKAGE	PKG. NO.
CA5420AM (5420A)	-55 to 125	8 Ld SOIC	M8.15

Pinout

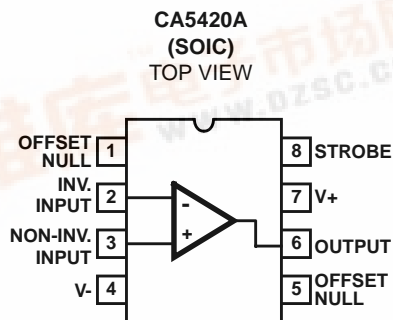

NOTE: Pin is connected to Case.



CA5420A

Absolute Maximum Ratings

Supply Voltage (Between V+ and V- Terminals)	22V
Differential Input Voltage	15V
Input Voltage	(V+ + 8V) to (V- - 0.5V)
Input Current	1mA
Output Short Circuit Duration (Note 1)	Indefinite

Thermal Information

Thermal Resistance (Typical, Note 2)	θ_{JA} (°C/W)	θ_{JC} (°C/W)
SOIC Package	157	N/A
Maximum Junction Temperature (Plastic Package)	150°C	
Maximum Storage Temperature Range (All Types)	-65°C to 150°C	
Maximum Lead Temperature (Soldering 10s)	300°C (SOIC - Lead Tips Only)	

Operating Conditions

Temperature Range -55°C to 125°C

CAUTION: Stresses above those listed in "Absolute Maximum Ratings" may cause permanent damage to the device. This is a stress only rating and operation of the device at these or any other conditions above those indicated in the operational sections of this specification is not implied.

NOTES:

1. Short circuit may be applied to ground or to either supply.
2. θ_{JA} is measured with the component mounted on an evaluation PC board in free air.

Electrical Specifications Typical Values Intended Only for Design Guidance. V+ = +5V; V- = GND, T_A = 25°C

PARAMETER		SYMBOL	TEST CONDITIONS		CA5420A	UNITS
Input Resistance		R _I			150	TΩ
Input Capacitance		C _I			4.9	pF
Output Resistance		R _O			300	Ω
Equivalent Input Noise Voltage		e _N	f = 1kHz	R _S = 100Ω	62	nV/√Hz
			f = 10kHz		38	nV/√Hz
Short-Circuit Current To Opposite Supply	Source	I _{OM+}			2.6	mA
	Sink	I _{OM-}			2.4	mA
Gain Bandwidth Product		f _T			0.5	MHz
Slew Rate		SR			0.5	V/μs
Transient Response	Rise Time	t _r	R _L = 2kΩ, C _L = 100pF		0.7	μs
	Overshoot	OS			15	%
Current from Terminal 8 To V-		I _{g+}			20	μA
Current from Terminal 8 To V+		I _{g-}			2	mA
Settling Time	0.01%	A _V = 1	2V _{P-P} Input		8	μs
	0.10%	A _V = 1	2V _{P-P} Input		4.5	μs

Electrical Specifications T_A = 25°C, V+ = 5V, V- = 0, Unless Otherwise Specified

PARAMETER	SYMBOL	TEST CONDITIONS	CA5420A			UNITS
			MIN	TYP	MAX	
Input Offset Voltage	V _{IO}	V _O = 2.5V	-	1	5	mV
Input Offset Current	I _{IO}	V _O = 2.5V	-	0.02	0.5	pA
Input Current	I _I	V _O = 2.5V	-	0.02	1	pA
Common Mode Rejection Ratio	CMRR	V _{CM} = 0 to 3.7V, V _O = 2.5V	75	83	-	dB
Common Mode Input Voltage Range	V _{ICR+}	V _O = 2.5V	3.7	4	-	V
	V _{ICR-}		-	-0.3	0	V
Power Supply Rejection Ratio	PSRR	ΔV+ = 1V; ΔV- = 1V	75	83	-	dB
Large Signal Voltage Gain	A _{OL}	V _O = 0.5 to 4V R _L = ∞	85	87	-	dB
		V _O = 0.5 to 4V R _L = 10kΩ	85	87	-	dB
		V _O = 0.7 to 3V R _L = 2kΩ	80	85	-	dB

CA5420A

Electrical Specifications $T_A = 25^\circ\text{C}$, $V_+ = 5\text{V}$, $V_- = 0$, Unless Otherwise Specified (Continued)

PARAMETER	SYMBOL	TEST CONDITIONS	CA5420A			UNITS
			MIN	TYP	MAX	
Source Current	I_{SOURCE}	$V_O = 0\text{V}$	1.2	2.7	-	mA
Sink Current	I_{SINK}	$V_O = 5\text{V}$	1.2	2.1	-	mA
Output Voltage	$V_{\text{OM}+}$	$R_L = \infty$	4.9	4.94	-	V
	$V_{\text{OM}-}$		-	0.13	0.15	V
	$V_{\text{OM}+}$	$R_L = 10\text{k}\Omega$	4.7	4.9	-	V
	$V_{\text{OM}-}$		-	0.12	0.15	V
	$V_{\text{OM}+}$	$R_L = 2\text{k}\Omega$	3.5	4.6	-	V
	$V_{\text{OM}-}$		-	0.1	0.15	V
Supply Current	I_{SUPPLY}	$V_O = 0\text{V}$	-	400	500	μA
		$V_O = 2.5\text{V}$	-	430	550	μA

Electrical Specifications $T_A = -55^\circ\text{C}$ to 125°C , $V_+ = 5\text{V}$, $V_- = 0$, Unless Otherwise Specified

PARAMETER	SYMBOL	TEST CONDITIONS	CA5420A			UNITS
			MIN	TYP	MAX	
Input Offset Voltage	V_{IO}	$V_O = 2.5\text{V}$	-	2	10	mV
Input Offset Current Up to $T_A = 85^\circ\text{C}$	I_{IO}	$V_O = 2.5\text{V}$	-	1.5	3	nA
			-	2	10	pA
Input Current Up to $T_A = 85^\circ\text{C}$	$ I_{\text{I}} $	$V_O = 2.5\text{V}$	-	2	5	nA
			-	10	15	pA
Common Mode Rejection Ratio	CMRR	$V_{\text{CM}} = 0$ to 3.7V , $V_O = 2.5\text{V}$	70	80	-	dB
Common Mode Input Voltage Range	$V_{\text{ICR}+}$	$V_O = 2.5\text{V}$	3.7	4	-	V
	$V_{\text{ICR}-}$		-	-0.3	0	V
Power Supply Rejection Ratio	PSRR	$\Delta V_+ = 1\text{V}$; $\Delta V_- = 1\text{V}$	70	83	-	dB
Large Signal Voltage Gain	A_{OL}	$R_L = \infty$	85	87	-	dB
		$R_L = 10\text{k}\Omega$	80	87	-	dB
		$R_L = 2\text{k}\Omega$	75	80	-	dB
Source Current	I_{SOURCE}	$V_O = 0\text{V}$	1	2.7	-	mA
Sink Current	I_{SINK}	$V_O = 5\text{V}$	1	2.1	-	mA
Output Voltage	$V_{\text{OM}+}$	$R_L = \infty$	4.8	4.9	-	V
	$V_{\text{OM}-}$		-	0.16	0.2	V
	$V_{\text{OM}+}$	$R_L = 10\text{k}\Omega$	4.7	4.9	-	V
	$V_{\text{OM}-}$		-	0.15	0.2	V
	$V_{\text{OM}+}$	$R_L = 2\text{k}\Omega$	3	4	-	V
	$V_{\text{OM}-}$		-	0.14	0.2	V
Supply Current	I_{SUPPLY}	$V_O = 0\text{V}$	-	430	550	μA
		$V_O = 2.5\text{V}$	-	480	600	μA

CA5420A

Electrical Specifications For Equipment Design at $V_{SUPPLY} = \pm 1V$, $T_A = 25^{\circ}C$, Unless Otherwise Specified

PARAMETER	SYMBOL	TEST CONDITIONS	CA5420A			UNITS
			MIN	TYP	MAX	
Input Offset Voltage	V_{IO}		-	2	5	mV
Input Offset Current	$ I_{IO} $		-	0.01	4 (Note 3)	pA
Input Current	$ I_I $		-	0.02	5 (Note 3)	pA
Large Signal Voltage Gain	A_{OL}	$R_L = 10k\Omega$	20	100	-	kV/V
			86	100	-	dB
Common Mode Rejection Ratio	CMRR		-	560	1000	$\mu V/V$
			60	65	-	dB
Common Mode Input Voltage Range	V_{ICR+}		0.2	0.5	-	V
	V_{ICR-}		-1	-1.3	-	V
Power Supply Rejection Ratio	PSRR		-	32	320	$\mu V/V$
			70	90	-	dB
Maximum Output Voltage	V_{OM+}	$R_L = \infty$	0.9	0.95	-	V
	V_{OM-}		-0.85	-0.91	-	V
Supply Current	I_{SUPPLY}		-	350	650	μA
Device Dissipation	P_D		-	0.7	1.1	mW
Input Offset Voltage Temp. Drift	$\Delta V_{IO}/\Delta T$		-	4	-	$\mu V/^{\circ}C$

Electrical Specifications For Equipment Design at $V_{SUPPLY} = \pm 10V$, $T_A = 25^{\circ}C$, Unless Otherwise Specified

PARAMETER	SYMBOL	TEST CONDITIONS	CA5420A			UNITS
			MIN	TYP	MAX	
Input Offset Voltage	V_{IO}		-	2	5	mV
Input Offset Current	$ I_{IO} $		-	0.03	4 (Note 3)	pA
Input Current	$ I_I $		-	0.05	5 (Note 3)	pA
Large Signal Voltage Gain	A_{OL}	$R_L = 10k\Omega$	20	100	-	kV/V
			86	100	-	dB
Common Mode Rejection Ratio	CMRR		-	100	320	$\mu V/V$
			70	80	-	dB
Common Mode Input Voltage Range	V_{ICR+}		9	9.3	-	V
	V_{ICR-}		-10	-10.3	-	V
Power Supply Rejection Ratio	PSRR		-	32	320	$\mu V/V$
			70	90	-	dB
Maximum Output Voltage	V_{OM+}	$R_L = \infty$	9.7	9.9	-	V
	V_{OM-}		-9.7	-9.85	-	V
Supply Current	I_{SUPPLY}		-	450	1000	μA
Device Dissipation	P_D		-	9	14	mW
Input Offset Voltage Temperature Drift	$\Delta V_{IO}/\Delta T$		-	4	-	$\mu V/^{\circ}C$

NOTE:

- The maximum limit represents the levels obtainable on high-speed automatic test equipment. Typical values are obtained under laboratory conditions.

CA5420A

Typical Applications

Picoammeter Circuit

The exceptionally low input current (typically 0.2pA) makes the CA5420A highly suited for use in a picoammeter circuit. With only a single 10GΩ resistor, this circuit covers the range from ±1.5pA. Higher current ranges are possible with suitable switching techniques and current scaling resistors. Input transient protection is provided by the 1MΩ resistor in series with the input. Higher current ranges require that this resistor be reduced. The 10MΩ resistor connected to pin 2 of the CA5420A decouples the potentially high input capacitance often associated with lower current circuits and reduces the tendency for the circuit to oscillate under these conditions.

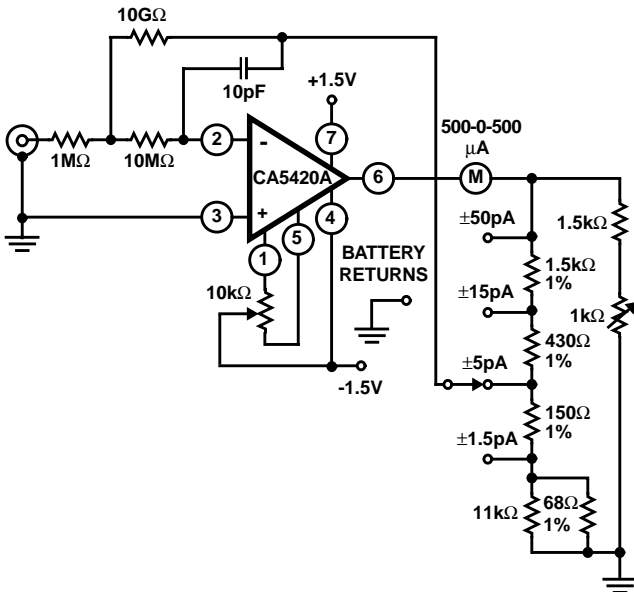

FIGURE 1. PICOAMMETER CIRCUIT

High Input Resistance Voltmeter

Advantage is taken of the high input impedance of the CA5420A in a high input resistance DC voltmeter. Only two 1.5V "AA" type penlite batteries power this exceedingly high-input resistance (>1,000,000MΩ) DC voltmeter. Full-scale deflection is ±500mV, ±150mV, and ±15mV. Higher voltage ranges are easily added with external input voltage attenuator networks.

The meter is placed in series with the gain network, thus eliminating the meter temperature coefficient error term.

Supply current in the standby position with the meter undeflected is 300μA. At full-scale deflection this current rises to 800μA. Carbon-zinc battery life should be in excess of 1,000 hours.

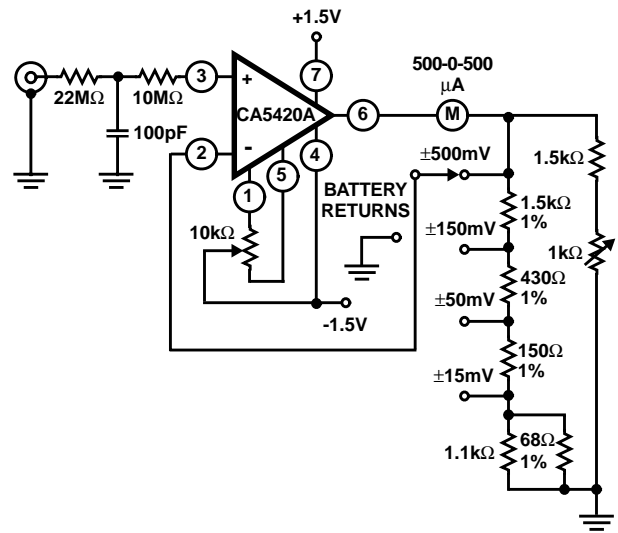

FIGURE 2. HIGH INPUT RESISTANCE VOLTMETER

Typical Performance Curves

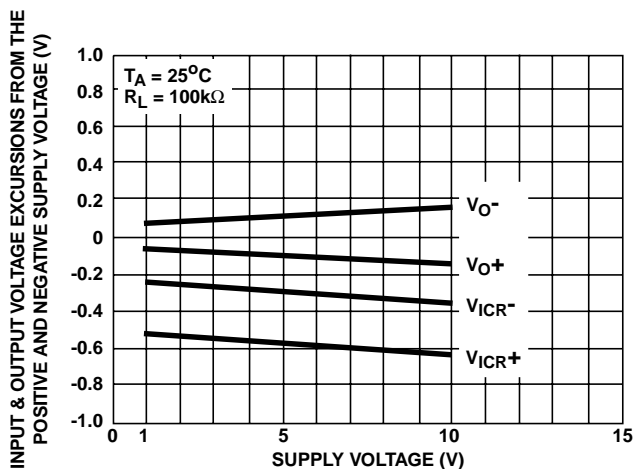

FIGURE 3. OUTPUT VOLTAGE SWING AND COMMON MODE INPUT VOLTAGE RANGE vs SUPPLY VOLTAGE

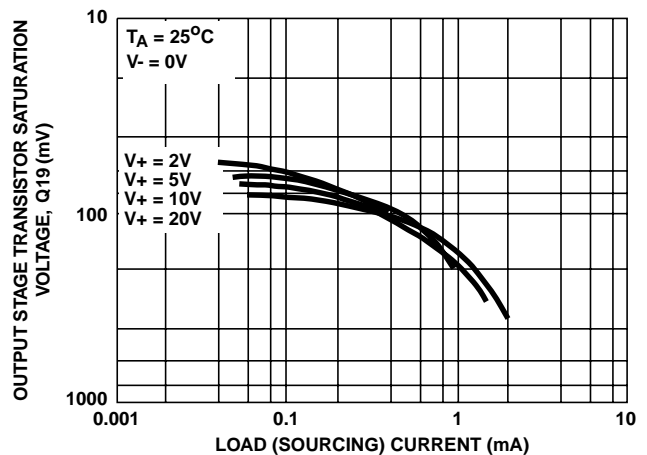

FIGURE 4. OUTPUT VOLTAGE vs LOAD SOURCING CURRENT

Typical Performance Curves (Continued)

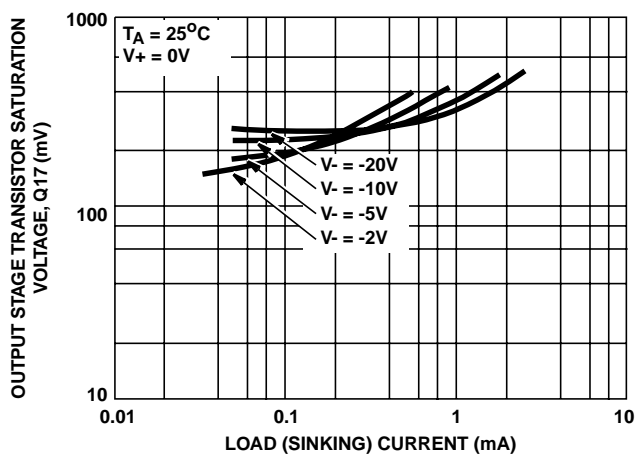

FIGURE 5. OUTPUT VOLTAGE vs LOAD SINKING CURRENT

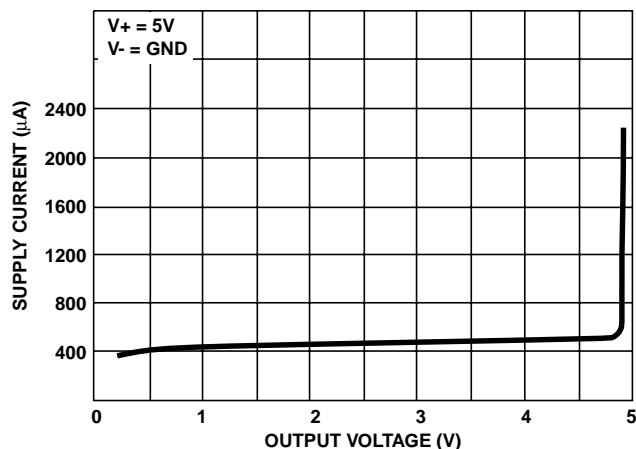

FIGURE 6. SUPPLY CURRENT vs OUTPUT VOLTAGE

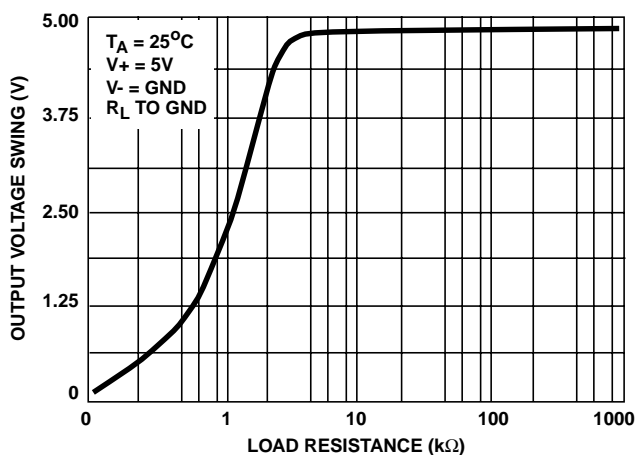

FIGURE 7. OUTPUT VOLTAGE SWING vs LOAD RESISTANCE

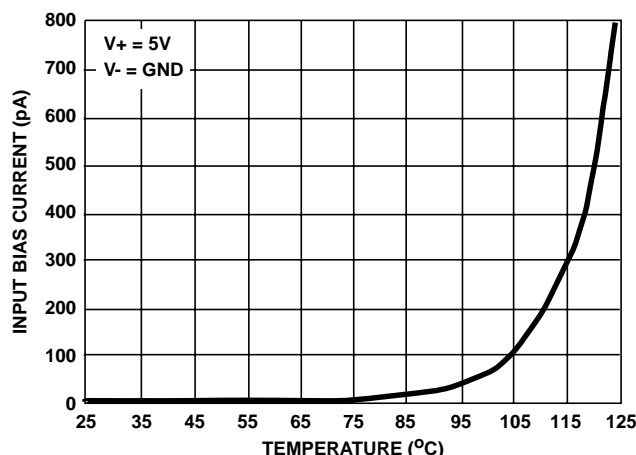

FIGURE 8. INPUT BIAS CURRENT DRIFT ($\Delta I_B/\Delta T$)

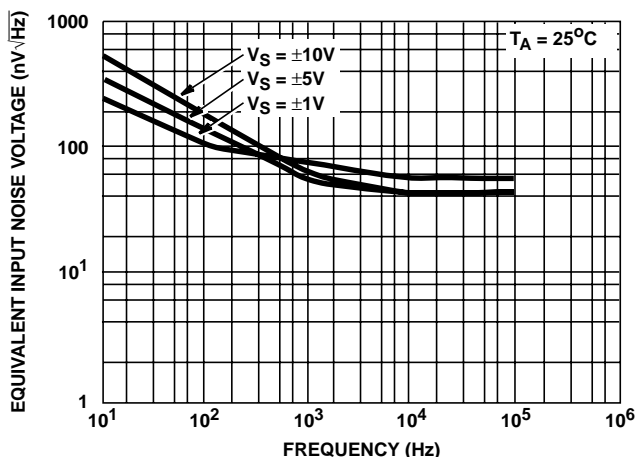

FIGURE 9. INPUT NOISE VOLTAGE vs FREQUENCY

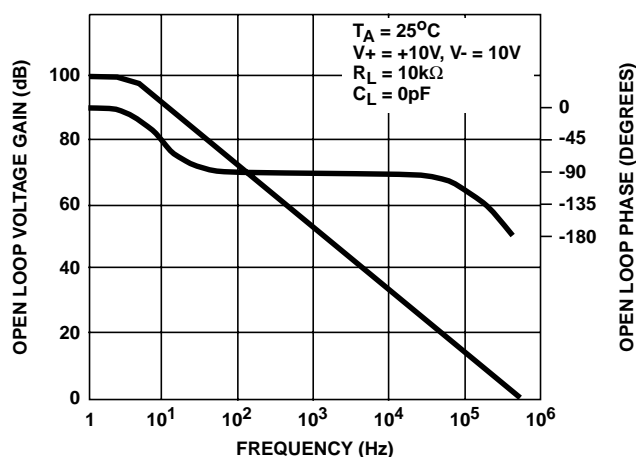

FIGURE 10. OPEN LOOP GAIN AND PHASE SHIFT RESPONSE

CA5420A

All Intersil semiconductor products are manufactured, assembled and tested under **ISO9000** quality systems certification.

Intersil semiconductor products are sold by description only. Intersil Corporation reserves the right to make changes in circuit design and/or specifications at any time without notice. Accordingly, the reader is cautioned to verify that data sheets are current before placing orders. Information furnished by Intersil is believed to be accurate and reliable. However, no responsibility is assumed by Intersil or its subsidiaries for its use; nor for any infringements of patents or other rights of third parties which may result from its use. No license is granted by implication or otherwise under any patent or patent rights of Intersil or its subsidiaries.

For information regarding Intersil Corporation and its products, see web site www.intersil.com

Sales Office Headquarters

NORTH AMERICA

Intersil Corporation
P. O. Box 883, Mail Stop 53-204
Melbourne, FL 32902
TEL: (321) 724-7000
FAX: (321) 724-7240

EUROPE

Intersil SA
Mercure Center
100, Rue de la Fusee
1130 Brussels, Belgium
TEL: (32) 2.724.2111
FAX: (32) 2.724.22.05

ASIA

Intersil (Taiwan) Ltd.
7F-6, No. 101 Fu Hsing North Road
Taipei, Taiwan
Republic of China
TEL: (886) 2 2716 9310
FAX: (886) 2 2715 3029