



September 1999

CLC5506 Gain Trim Amplifier (GTA)

General Description

The CLC5506 is a low-noise amplifier with programmable gain for use in cellular base stations, WLL, radar and RF/IF subsystems where gain-control is required to increase the dynamic range. The CLC5506 allows designers to compensate for manufacturing component tolerances and temperature variations in receiver front ends. Maximum amplifier gain is set at 26dB . A three-line MICROWIRE serial interface allows 16dB of attenuation from the max gain setting in precise 0.25dB steps.

The CLC5506 uses a differential input and output, allowing large output swings on a single 5V rail. The differential output is well suited for impedance matching networks driving SAW filters or directly driving differential input analog to digital converters (ADC). The differential output also makes it possible to drive transformers allowing designers the ability to match a wide variety of transmission lines. The output amplifier has excellent output drive with low distortion.

Digital control of the CLC5506 is accomplished using MICROWIRE Interface. Data Out and a Load Enable are incorporated so that more than one CLC5506/channel may be programmed per system.

The CLC5506 maintains a 600MHz performance bandwidth over its entire gain and attenuation range from +10dB to +26dB. Gain control is divided into 64 equal steps of 0.25dB and is dB-linear. Output drive and distortion performance are excellent; In a 50Ω system, the third-order output intercept point is +22dBm at nominal gain of 18dB at 25°C. The CLC5506 operates over the industrial temperature range of -40°C to +85°C.

Features

- 600MHz bandwidth
- 26dB maximum gain @ 150MHz
- 16dB gain control range
- Attenuation step size: 0.25dB
- 4.8dB noise figure @ 26dB
- +22dBm output IP3 @ 18dB gain
- Digital "dB Linear" gain control
- Supply voltage: 5V
- Supply current: 75mA
- Supply shutdown: 35μA
- Package: SOIC-14
- Typical at 25°C

Applications

- Cellular base-stations
- Base station repeater
- Wireless Local Loop
- Radar
- Receivers
- IF amplifiers
- Digital IF receiver
- Software radio
- Satellite communications

Frequency Response vs. Gain Setting

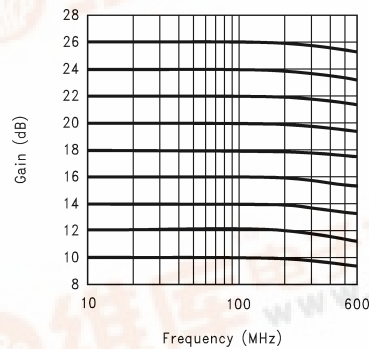

DS101050-1

CLC5506Gain Trim Amplifier (GTA)

MICROWIRE™



Typical Application

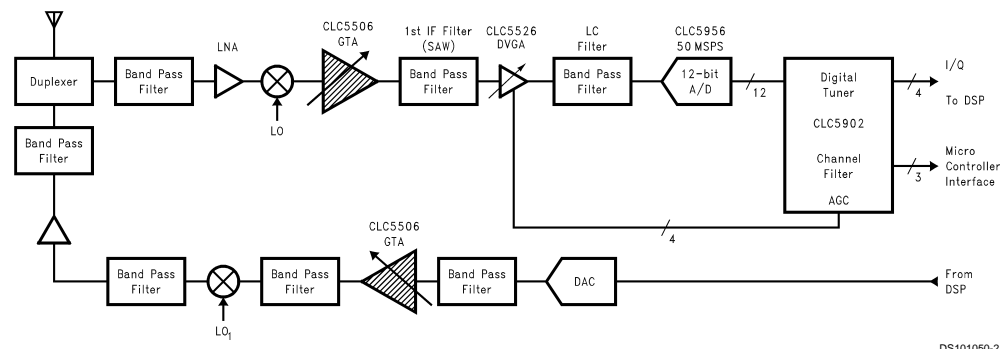

DS101050-2

Connection Diagram

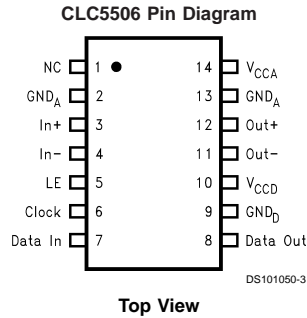

Pin #	Pin Name	Description
1	NC	No connection
2	GND _A	Analog ground
3	In+	Positive differential input
4	In-	Negative differential input
5	LE	MICROWIRE load enable input. High impedance CMOS input with Schmitt trigger
6	Clock	MICROWIRE clock input. High impedance CMOS input with Schmitt trigger. Data is clocked in on the rising edge of clock.
7	Data In	MICROWIRE data input. High impedance CMOS input with Schmitt trigger. Binary serial data. Data entered Power Down first.
8	Data Out	MICROWIRE data output. High impedance CMOS input with Schmitt trigger.
9	GND _D	Digital ground
10	V _{CCD}	Digital supply voltage
11	Out-	Negative differential Output
12	Out+	Positive differential output
13	GND _A	Analog ground
14	V _{CCA}	Analog supply voltage

Ordering Information

Package	Temperature Range	Transport Media	NSC Drawing
	-40°C to +85°C		
SO-14	CLC5506IM	Rails	M14a
	CLC5506IMX	2.5k Units Tape and Reel	
	CLC5506PCASM		Fully loaded evaluation board

Absolute Maximum Ratings (Note 1)

If Military/Aerospace specified devices are required, please contact the National Semiconductor Sales Office/ Distributors for availability and specifications.

ESD tolerance(Note 2)	
Human body model	2.5KV
Machine model	250V
Differential input voltage	+/-1V
Supply voltage	-0.3 to +6V
Digital input voltage	-0.3V to V_{CC}
Analog input voltage	-0.3V to V_{CC}
Output short circuit duration	Infinite
Lead temperature (soldering, 10 sec)	+300°C

Storage temperature range	-65°C to 150°C
Junction temperature	155°C
Differential voltage between any two inputs	<200mV

Operating Ratings (Note 1)

Supply voltage (pins 10 and 14)	5V +/- 10%
Ambient temperature range	-40°C to +85°C
Junction Temperature Range	-40°C to +150°C
Package thermal resistance, θ_{JA}	127°C/W

Electrical Characteristics

These conditions apply unless otherwise specified: $T_J = 25^\circ\text{C}$, $V_{CCA} = V_{CCD} = +5\text{V}$: Gain = 25.75dB, $R_{Ldiff} = 100\Omega$, Pin = -30dBm (Note 6),(Note 7).

Symbol	Parameter	Conditions	Typ (Note 3)	Limit (Note 4)	Units
Analog I/O					
Frequency Response/Distortion/Noise					
	upper -3dB bandwidth	All Gain Codes	600		MHz
	upper -1dB bandwidth	All Gain Codes		400	MHz
	gain flatness in any 1MHz band	10MHz < f < 600MHz, All Gain Codes	0.003		dB
	group delay	50MHz < f < 600MHz	1.5		nsec
	group delay ripple	50MHz < f < 600MHz	0.5		nsec
	output third order intercept point	18dB Gain, f = 110MHz	22		dBm
	noise figure	Gain = 25.75dB, (Note 6)	4.8		dB
		Gain = 18dB, (Note 6)	5.7		dB
		Gain = 10dB, (Note 6)	7.0		dB
	1dB output compression point	150MHz	4.0		dBm
	2 nd harmonic distortion	Pin = -30 dBm, fc = 200MHz @ Gain = 25.75dB @ Gain = 10dB	46		dBc
			46		dBc
	3 rd harmonic distortion	Pin = -30 dBm, fc = 200MHz @ Gain = 25.75dB @ Gain = 10dB	49		dBc
			56		dBc
	Input/Output Isolation power down mode	Full frequency band	45		dB
Gain Parameters: (Note 5)					
	maximum gain	Full temperature range	25.75		dB
	minimum gain	Full temperature range	10		dB
	gain step size	Full temperature range	0.25		dB
	accuracy of gain setting	@ 25°C	±0.05		dB
	gain variation over temperature	Full temperature range	±0.5		dB
Input/Output Characteristics:					
	input resistance	Differential	200		Ω
	input capacitance	Differential	0.5		pF

Electrical Characteristics (Continued)

These conditions apply unless otherwise specified: $T_J = 25^\circ\text{C}$, $V_{CCA} = V_{CCD} = +5\text{V}$; Gain = 25.75dB, $R_{Ldiff} = 100\Omega$, Pin = -30dBm (Note 6), (Note 7).

Symbol	Parameter	Conditions	Typ (Note 3)	Limit (Note 4)	Units
Input/Output Characteristics:					
	output resistance	Differential	5K		Ω
	output capacitance	Differential	0.5		pF
Logic I/O					
	clock speed	Maximum	1		MHz
	data to clock setup time, T_{CS}	Minimum	50		nsec
	data to clock hold time, T_{CH}	Minimum	10		nsec
	clock pulse width high, T_{CWH}	Minimum	50		nsec
	clock pulse width low, T_{CWL}	Minimum	50		nsec
	clock to load enable setup time, T_{ES}	Minimum	50		nsec
	high level input voltage		$0.7 V_{CCD}$		V
	low level input voltage		$0.3 V_{CCD}$		V
	High level input current		± 1.0		μA
	low level input current		± 1.0		μA
	high level output voltage	Isorce = 0.5mA	$V_{CCD} - 0.8$		V
	low level output voltage	Isink = 0.5mA	0.4		V
DC Characteristics:					
	Supply current		75	95	mA
	Supply current in power down mode		35	100	μA

Note 1: Absolute Maximum Ratings indicate limits beyond which damage to the device may occur. Operating Ratings indicate conditions for which the device is intended to be functional, but specific performance is not guaranteed. For guaranteed specifications and the test conditions, see the Electrical Characteristics.

Note 2: Human body model, 1.5k Ω in series with 100pF. Machine model, 200 Ω in series with 100pF.

Note 3: Typical values represent the most likely parametric norm.

Note 4: All limits are guaranteed by testing or statistical analysis, unless otherwise noted.

Note 5: AC test performed at 400MHz unless otherwise noted.

Note 6: Refer to test circuit schematic, loss of transformers is excluded from the measurement.

Note 7: Refer to test circuit schematic to see the definition of R_{Ldiff} .

Typical Performance Characteristics ($V_{CCA} = V_{CCD} = +5V$, $R_{Ldiff} = 100\Omega$, $T_A = 25^\circ C$, unless otherwise specified.)

Frequency Response vs. Gain Setting (0.25dB/step)

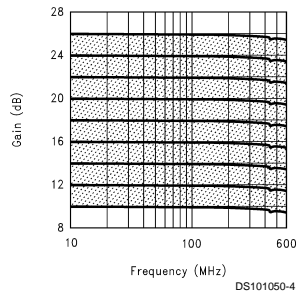

Gain vs. Input Code

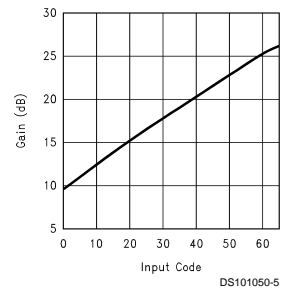

Gain Error vs. Input Code

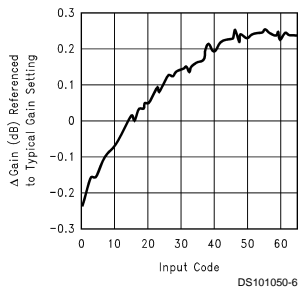

Output 3rd Order Intercept vs. Input Code

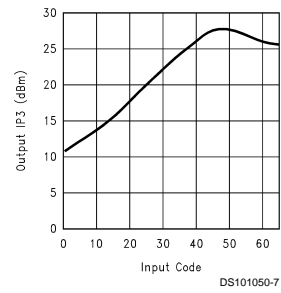

Input 3rd Order Intercept vs. Input Code

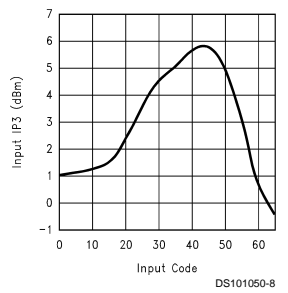

Noise Figure vs. Input Code

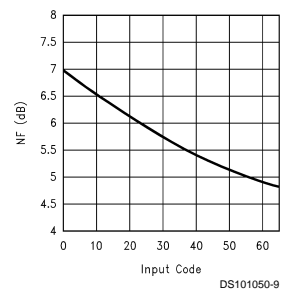

Gain Change Over Temperature vs. Frequency

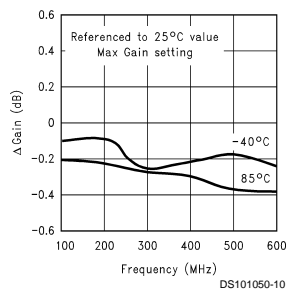

Gain Change Over Temperature vs. Frequency

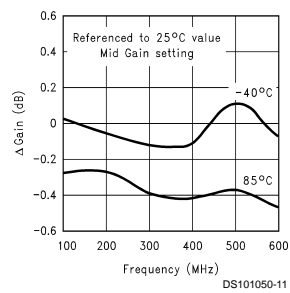

Typical Performance Characteristics ($V_{CCA} = V_{CCD} = +5V$, $R_{Ldiff} = 100\Omega$, $T_A = 25^\circ C$, unless otherwise specified.) (Continued)

Gain Change Over Temperature vs. Frequency

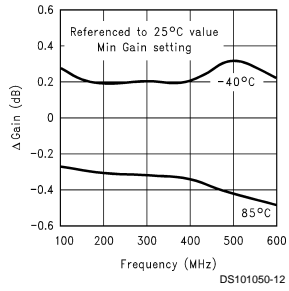

NF Change Over Temperature vs. Frequency

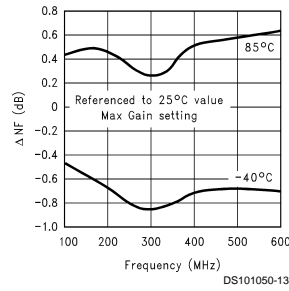

NF Change Over Temperature vs. Frequency

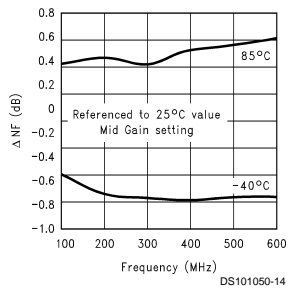

NF Change Over Temperature vs. Frequency

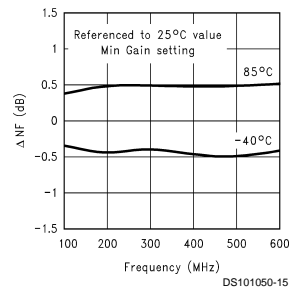

P_{1dB} vs. Gain Setting

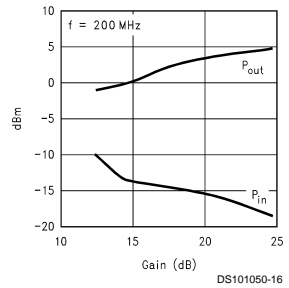

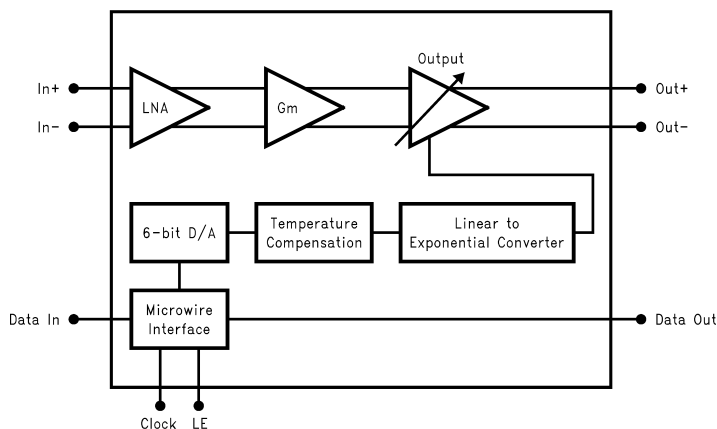

FIGURE 1. CLC5506 Functional Block Diagram

DS101050-17

APPLICATION NOTE

Description

Figure 1 above shows the CLC5506 functional block diagram overview.

The LNA (Low Noise Amplifier) is responsible for maintaining a nominal input impedance of 200Ω with minimum noise contribution and some finite and fixed amount of gain (-4). Exceptional Noise Figure (NF) performance of 4.8dB (@ Gain = 25.75dB) is achieved by utilizing an active impedance matching circuit technique which overcomes the inevitable 3dB NF penalty when using passive shunt matching.

The LNA stage is immediately followed by a transconductance stage (Gm) which then converts the LNA's voltage output into a differential current output with fixed gain.

The 6-bit D/A converter, which processes the digital code read into the device using the MICROWIRE interface, consists of a 6-bit R2R ladder. In order to achieve true "Linear in dB" gain control at the output, the D/A converter output is processed by a "Linear to Exponential" converter block be-

fore being used to set the gain of the input signal. The "Linear to Exponential" block and the "Temperature Compensation" blocks work in conjunction to achieve gain stability over the temperature range. Finally, the output stage consists of a variable gain cell with open Collector output. This variable gain cell sets the signal channel gain in accordance with the value of the digital code.

Gain Control

The CLC5506 minimum gain is at 10dB nominal. There are a total of 64 distinct gain control codes possible (serial data input through Data In pin) at 0.25dB/code resulting in a maximum nominal gain of 25.75dB.

Therefore, the overall gain can be written as:

$$\text{Gain (dB)} = 10\text{dB} + N_{\text{code}} * 0.25 \text{ (dB/code)}$$

where N_{code} refers to the decimal equivalent of the 6-bit gain control code.

TABLE 1.

Gain	Typical Gain Setting (dB)	Note
0	10	Minimum Gain Setting
1	10.25	
2	10.5	
***	***	
K	$10 + 0.25 * K$	
***	***	
62	25.50	
63	25.75	Maximum Gain Setting

Power Down

The CLC5506 is able to go to a Power Down mode in order to minimize its power consumption to a fraction of its nominal value. The Power Down mode is activated through the MICROWIRE interface by clocking in a "1" into the Power Down shift register prior to allowing LE (pin 5) to go high. Refer to Figure 2 and Figure 3 for more information.

In Power Down mode, the CLC5506 sinks less than $35\mu\text{A}$. The CLC5506 will wake up to the requested gain level specified by Data In through the MICROWIRE interface.

When V_{CC} is first applied, the device is configured such that it would always "wake up" with a nominal gain of 17.75dB ($N_{\text{code}} = 3$).

APPLICATION NOTE (Continued)

MICROWIRE™ Interface

Data In along with the Clock, LE, and Data Out, is used for the following purposes:

- Setting the 6-bit gain control code
 - Putting the device into a Power Up/Down mode to minimize power consumption
 - Daisy chain several CLC5506 or other MICROWIRE Interface devices through the Data Out pin
- The MICROWIRE interface timing diagram along with the bit assignment of all 8 bits is shown in *Figure 2*. The interface is active only when LE (pin 5) is low; otherwise, the interface is inactive (Clock and Data In are ignored) and the CLC5506 gain is the current content of the 6 bits already read into the device.

With LE low, each successive positive transition of Clock will read the value of the Data In into a series of 8 single bit shift registers. In order to load all 8 registers, 8 Clock transitions are required after which, when LE is allowed to go High, the new values in the shift registers are latched to determine the device gain setting (or Power Down state). New data can be shifted into the device with the present gain setting not affected as long as LE is held low.

Data from the last register in the chain is clocked out on Data Out pin on the negative transitions of Clock as shown in *Figure 3*. This enables several MICROWIRE Interface devices to be daisy chained and controlled from a single bus master. The maximum clock frequency (Clock pin) is 1MHz.

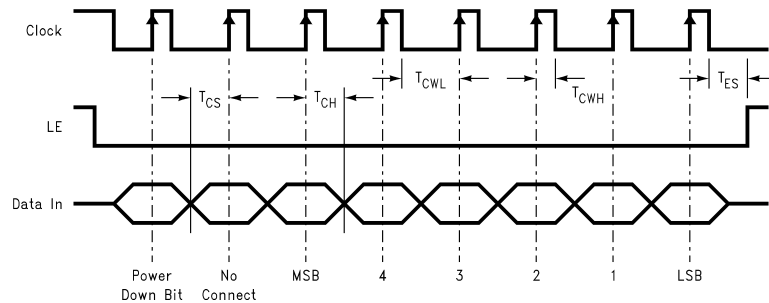

DS101050-18
Note:

1. Data is clocked in on the rising edge of Clock.
2. Power Down bit is the first data to enter the CLC5506.

FIGURE 2. MICROWIRE Interface Timing Diagram

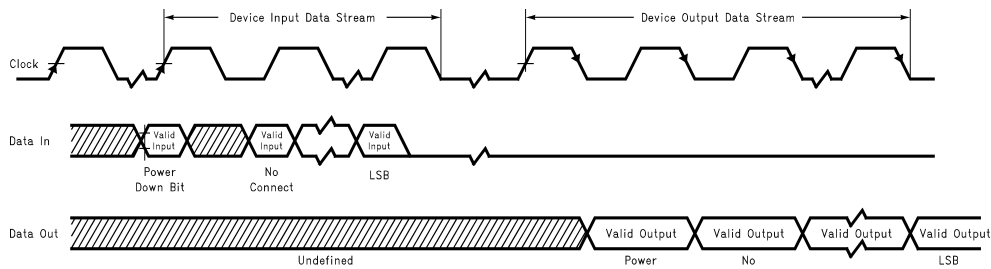

DS101050-19

FIGURE 3. MICROWIRE Interface Serial Data Out Timing

APPLICATION NOTE (Continued)

Differential Input and Output Considerations

The CLC5506 typical application requires DC blocking capacitors for both inputs and outputs to main internal DC biasing points.

The input impedance between the differential inputs (IN+, IN-) is $200\Omega/0.5\text{pF}$. Since the 0.5pF capacitance can be neglected in the VHF band, a 1:4 impedance ratio balun can be used to transform a 50Ω source to the 200Ω differential inputs of CLC5506 for wide band design.

The CLC5506 has a pair of open collector differential outputs (OUT+, OUT-). DC biasing is achieved through an RF inductor. The RF inductor acts as a choke to block RF leakage and interference. An external resistor across the differential out-

puts is used to set the output resistance of CLC5506. Wide-band output matching to an unbalanced 50Ω load can be achieved by using a 1:n balun. A 1:4 impedance ratio balun is used when a 200Ω external resistor is used in a 50Ω system.

Although the CLC5506 can be used as a single-ended device by grounding one of the inputs through a capacitor, the noise figure would be severely degraded by 6dB.

The CLC5506 can also directly interface to balanced devices, like SAW filters and ADCs. Narrowband design example with ADC CLC5956 and SAW filter is provided below. The component values of matching inductors and capacitors depend on the actual input/output impedance of the SAW filter, ADC, PWB properties, layout and frequency band.

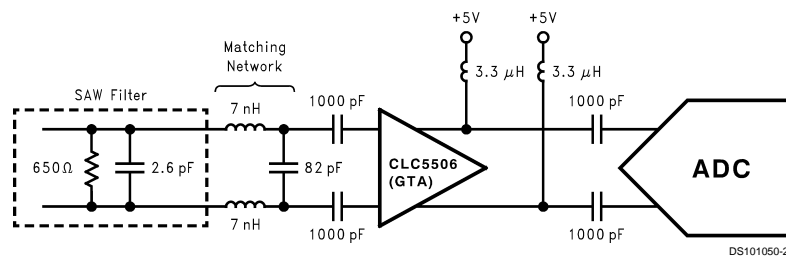
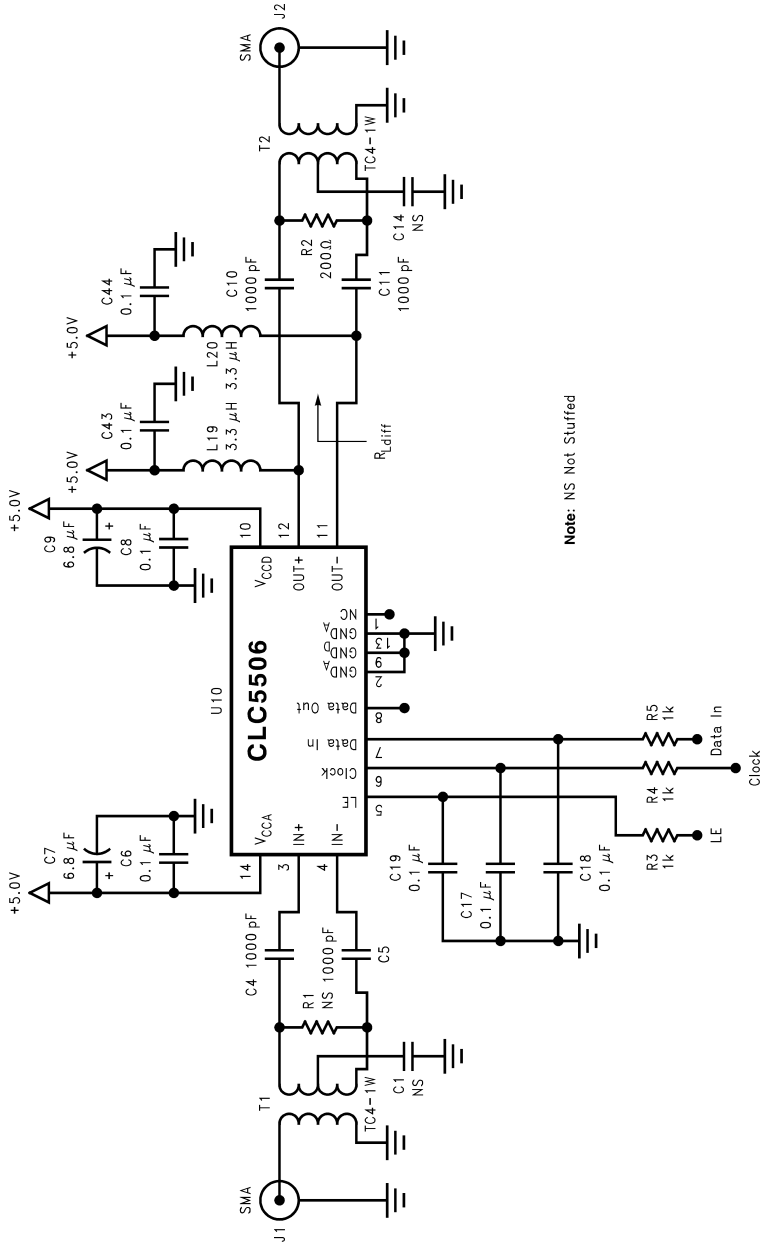

FIGURE 4. Narrow band design example with balanced SAW filter and ADC

CLC5506 Evaluation Board

A proper printed circuit layout is essential for achieving high frequency performance. To expedite evaluation, an assembled and tested evaluation kit CLC5506PCASM is available for sale. See application note AN-1138 for technical details of evaluation kit. Order information and application note is available on the Web at <http://www.national.com>

CLC5506 Test Circuit Schematic



Note: NS Not Stuffed

DS101050-21

Physical Dimensions inches (millimeters) unless otherwise noted

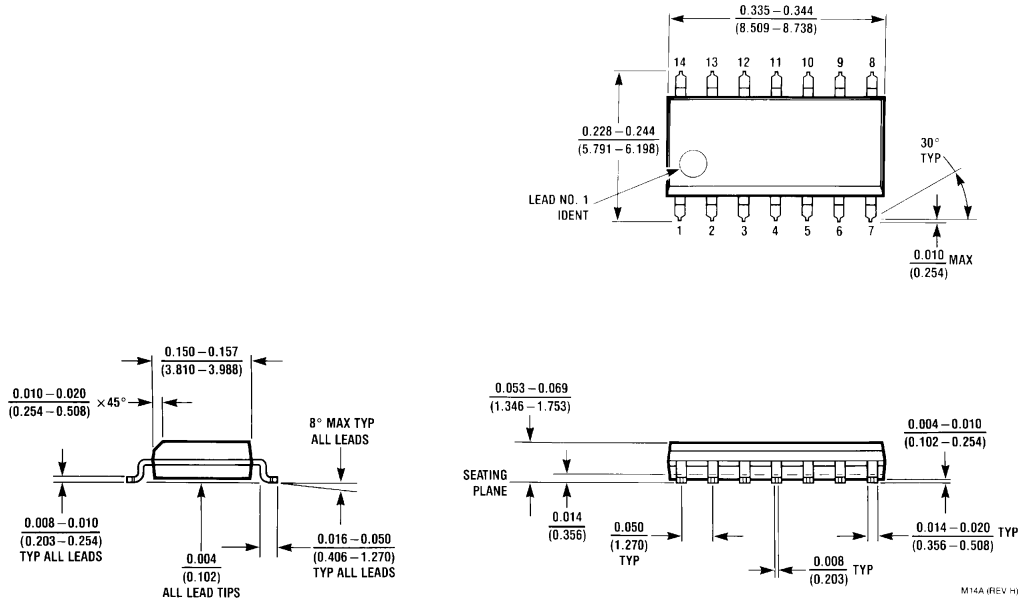

**14-Pin Small Outline
NSC Package Number M14A**

LIFE SUPPORT POLICY

NATIONAL'S PRODUCTS ARE NOT AUTHORIZED FOR USE AS CRITICAL COMPONENTS IN LIFE SUPPORT DEVICES OR SYSTEMS WITHOUT THE EXPRESS WRITTEN APPROVAL OF THE PRESIDENT AND GENERAL COUNSEL OF NATIONAL SEMICONDUCTOR CORPORATION. As used herein:

1. Life support devices or systems are devices or systems which, (a) are intended for surgical implant into the body, or (b) support or sustain life, and whose failure to perform when properly used in accordance with instructions for use provided in the labeling, can be reasonably expected to result in a significant injury to the user.
2. A critical component is any component of a life support device or system whose failure to perform can be reasonably expected to cause the failure of the life support device or system, or to affect its safety or effectiveness.



National Semiconductor Corporation
Americas
Tel: 1-800-272-9959
Fax: 1-800-737-7018
Email: support@nsc.com

National Semiconductor Europe
Fax: +49 (0) 1 80-530 85 86
Email: europe.support@nsc.com
Deutsch Tel: +49 (0) 1 80-530 85 85
English Tel: +49 (0) 1 80-532 78 32
Français Tel: +49 (0) 1 80-532 93 58
Italiano Tel: +49 (0) 1 80-534 16 80

National Semiconductor Asia Pacific Customer Response Group
Tel: 65-2544466
Fax: 65-2504466
Email: sea.support@nsc.com

National Semiconductor Japan Ltd.
Tel: 81-3-5639-7560
Fax: 81-3-5639-7507

www.national.com