

Converter IC for Capacitive Signals

CAV424

FEATURES

- **Ratiometric Supply Voltage: $5V \pm 5\%$**
- **Wide Operating Temperature Range: $-40^{\circ}C...+85^{\circ}C$**
- **High Detection Sensitivity of Relative Capacitive Changes: 5% – 100%**
- **Detection Frequency up to 2kHz**
- **Differential Output Signal with Great Voltage Swing**
- **Integrated Temperature Sensor**
- **Adjustable with only two Resistors**

APPLICATIONS

- Industrial Process Control
- Distance Measurement
- Pressure Measurement
- Humidity Measurement
- Level Control

BLOCK DIAGRAM

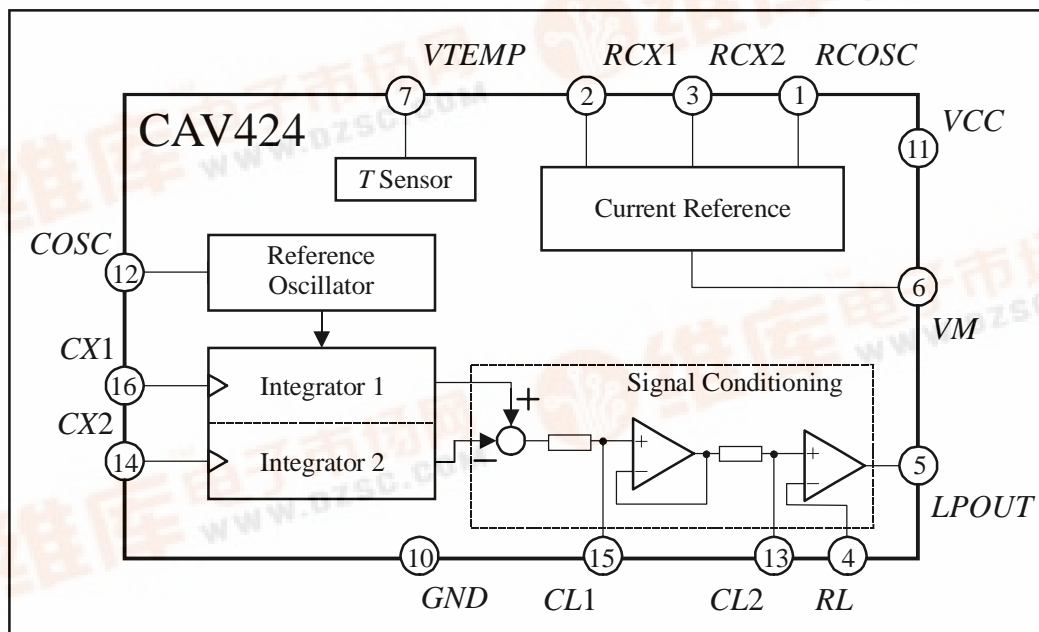

Figure 1: block diagram CAV424

GENERAL DESCRIPTION

The CAV424 is an integrated C/V converter and contains the complete signal processing unit for capacitive signals on chip. The CAV424 detects the relative capacitive change of a measuring capacity to a fixed reference capacity. The IC is optimised for capacities in the wide range of 10pF to 2nF with possible changes of capacity of 5% to 100% of the reference capacity. The differential voltage output signal can be directly connected to a following A/D converter or another signal conditioning IC from Analog Microelectronics. Using the integrated temperature sensor, digital adjustable systems can be built easily.

DELIVERY

- DIL16 packages
- SO16(n) packages
- Dice put on 5" blue foil

ELECTRICAL SPECIFICATIONS

$T_{amb} = 25^{\circ}\text{C}$, $V_{CC} = 5\text{V}$ (unless otherwise noted)

Parameter	Symbol	Conditions	Min.	Typ.	Max.	Unit
Supply						
Supply Voltage	V_{CC}	ratiometric range	4.75	5.00	5.25	V
Maximum Supply Voltage	V_{CCmax}				17	V
Quiescent Current	I_{CC}	$T_{amb} = -40 \dots 85^{\circ}\text{C}$, $G_{LP} = 1$	0.6	1.0	1.4	mA
Temperature Specifications						
Operating	T_{amb}		-40		85	$^{\circ}\text{C}$
Storage	T_{st}		-55		125	$^{\circ}\text{C}$
Junction	T_j				150	$^{\circ}\text{C}$
Thermal Resistance	Θ_{ja}	DIL16 plastic package		70		$^{\circ}\text{C}/\text{W}$
	Θ_{ja}	SO16 (n) plastic package		140		$^{\circ}\text{C}/\text{W}$
Reference Oscillator						
Oscillator Capacitor Range	C_{OSC}	$C_{OSC} = 1.6 \cdot C_{X1}$	14		1800	pF
Oscillator Frequency Range	f_{OSC}		1		130	kHz
Oscillator Current	I_{OSC}	$R_{OSC} = 250\text{k}\Omega$	9.5	10	10.75	μA
Capacitive Integrator 1 and 2						
Capacitor Range 1	C_{X1}		10		1000	pF
Capacitive Integrator Current 1	I_{X1}	$R_{CX1} = 500\text{k}\Omega$	4.75	5	5.38	μA
Capacitor Detection Sensitivity	ΔC_X	$\Delta C_X = (C_{X2} - C_{X1})/C_{X1}$	5		100	%
Capacitor Range 2	C_{X2}	$C_{X2} = C_{X1} \cdot (1 + \Delta C_X)$	10.5		2000	pF
Capacitive Integrator Current 2	I_{X2}	$R_{CX2} = 500\text{k}\Omega$	4.75	5	5.38	μA
Detection Frequency	f_{DET}	$C_{L1} = C_{L2} = 1\text{nF}$			2	kHz
Lowpass						
Adjustable Gain	G_{LP}		1		10	
Output Voltage	V_{LPOUT}		1.1		$V_{CC} - 1.1$	V
Corner Frequency 1	f_{C1}	$R_{01} = 20\text{k}\Omega$, $C_{L1} = 1\text{nF}$			8	kHz
Corner Frequency 2	f_{C2}	$R_{02} = 20\text{k}\Omega$, $C_{L2} = 1\text{nF}$			8	kHz
Resistive Load at PIN $LPOUT$	R_{LOAD}		200			$\text{k}\Omega$
Capacitive Load at PIN $LPOUT$	C_{LOAD}				50	pF
Temperature Coefficient V_{DIFF} (together with Input Stages)	dV_{DIFF}/dT	$V_{DIFF} = V_{LPOUT} - V_M$, $T_{amb} = -40 \dots 85^{\circ}\text{C}$		± 100		ppm/ $^{\circ}\text{C}$
Internal Resistor 1 and 2	R_{01} , R_{02}			20		$\text{k}\Omega$
Temperature Coefficient $R_{01,02}$	$dR_{01,02}/dT$	$T_{amb} = -40 \dots 85^{\circ}\text{C}$		1.9		$10^{-3}/^{\circ}\text{C}$
Ratiometric Error of V_{LPOUT}	$RAT@V_{DIFF}^*$			0.11		%FS

* $RAT @ V_{DIFF} = 2 [1.05 V_{DIFF}(V_{CC} = 5\text{V}) - V_{DIFF}(V_{CC} = 5.25\text{V})] / [V_{DIFF}(V_{CC} = 5\text{V}) + V_{DIFF}(V_{CC} = 5.25\text{V})]$

Parameter	Symbol	Conditions	Min.	Typ.	Max.	Unit
Voltage Reference V_M						
Voltage	V_M			2.5		V
V_M vs. Temperature	dV_M/dT	$T_{amb} = -40...+85^{\circ}\text{C}$		± 20	± 50	ppm/ $^{\circ}\text{C}$
Current	I_{VM}	Source			16	μA
	I_{VM}	Sink			-16	μA
Load Capacitance	C_{VM}		80	100	120	nF
Ratiometric Error of V_M	$RAT@V_M^{**}$			0.007		%FS
Temperature Sensor V_{TEMP}						
Voltage	V_{TEMP}	$R_{TEMP} \geq 50\text{M}\Omega$	2.20	2.32	2.45	V
Sensitivity	dV_{TEMP}/dT	$R_{TEMP} \geq 50\text{M}\Omega$		8		mV/ $^{\circ}\text{C}$
Thermal Nonlinearity		$R_{TEMP} \geq 50\text{M}\Omega$, end point method		0.5		%FS

** $RAT @ V_M = 2 [1.05 V_M(V_{CC} = 5\text{V}) - V_M(V_{CC} = 5.25\text{V})] / [V_M(V_{CC} = 5\text{V}) + V_M(V_{CC} = 5.25\text{V})]$

Note:

- 1) The oscillator capacity has to be chosen in the following way: $C_{OSC} = 1.6 \cdot C_{X1}$
- 2) The capacitor range of C_{X1} and C_{X2} can be extended whereby the system performance is reduced and the electrical limits are exceeded.
- 3) Currents flowing into the IC, are negative.
- 4) R_{TEMP} is the minimum load resistance at pin V_{TEMP}

BOUNDARY CONDITIONS

Parameter	Symbol	Min.	Typ.	Max.	Unit
Current Definition of Ref. Oscillator	R_{COSC}	235	250	265	k Ω
Current Adjustment of Cap. Integrator 1	R_{CX1}	475	500	525	k Ω
Current Adjustment of Cap. Integrator 2	R_{CX2}	475	500	525	k Ω
Output Stage Resistor Sum	$R_{L1} + R_{L2}$	90		200	k Ω
Reference Voltage 2.5V (only for internal use)	C_{VM}	80	100	120	nF
Lowpass Capacitance 1	C_{L1}	$100 \cdot C_{X1}$	$200 \cdot C_{X1}$		
Lowpass Capacitance 2	C_{L2}	$100 \cdot C_{X1}$	$200 \cdot C_{X1}$		
Oscillator Capacitance	C_{OSC}	$C_{OSC} = 1.55 \cdot C_{X1}$	$C_{OSC} = 1.60 \cdot C_{X1}$	$C_{OSC} = 1.65 \cdot C_{X1}$	

Note: The system performance over temperature forces that the resistors R_{CX1} , R_{CX2} and R_{OSC} have the same temperature coefficient and a very close placement of them in the circuit. The capacities C_{X1} , C_{X2} and C_{OSC} are also forced to have the same temperature coefficient and a very close placement of them in the circuit.

FUNCTIONAL DESCRIPTION

The CAV424 functions according to the following principle. A variable reference oscillator, whose frequency is set via capacitance C_{OSC} , drives two symmetrical integrators which are phase-locked and clock-synchronised. The amplitudes of the two driven integrators are determined by capacitances C_{X1} and C_{X2} , where C_{X1} is designated as the (measurement signal) reference capacitance and C_{X2} as the measurement signal capacitance. With high common-mode rejection ratio and a high resolution, com-

parison of the two amplitudes produces a signal which corresponds to the change in capacitance of C_{X1} and C_{X2} relative to one another. This difference signal is rectified in an ensuing low pass. The filtered DC signal is transferred to the differential, adjustable output stage. Individual circuit variables, such as filter constants and amplification, can be set with just a few external components. By using the integrators and their capacitances

C_{X1} and C_{X2} , swings in capacitance of 5% to 100% in relation to the measurement reference capacitance can be measured. As C_{X1} can be varied in a range of 10 pF to 1 nF, the range of measurement for the measurement signal capacitance is 0-10.5 pF to 0-2 nF.

The way a capacitive sensor functions whose signal can be conditioned with a CAV424 is described in detail in the following section. Simple dimensional requirements are given, permitting a sensor system to be assembled.

The CAV424 reference oscillator

The reference oscillator charges up and then discharges the external oscillator capacitance C_{OSC} , the internal parasitic capacitance of the IC, $C_{OSC,PAR,INT}$, and the external parasitic capacitance $C_{OSC,PAR,EXT}$ (from a printed board assembly, for example). Oscillator capacitance C_{OSC} is dimensioned as follows:

$$C_{OSC} = 1.6 \cdot C_{X1},$$

where C_{X1} is the fixed capacitance (reference capacitance) of a capacitive sensing element.

The reference oscillator current I_{OSC} is determined via external resistance R_{OSC} and reference voltage V_M :

$$I_{OSC} = \frac{V_M}{R_{OSC}}$$

The frequency of the reference oscillator f_{OSC} is given by

$$f_{OSC} = \frac{I_{OSC}}{2 \cdot \Delta V_{OSC} \cdot (C_{OSC} + C_{OSC,PAR,INT} + C_{OSC,PAR,EXT})},$$

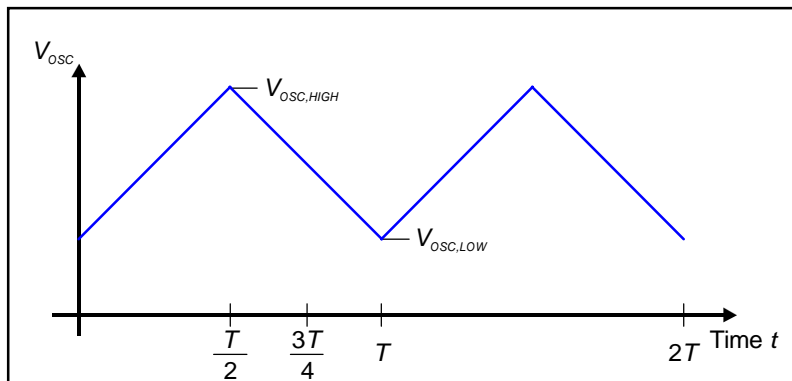

Figure 2: oscillator voltage curve

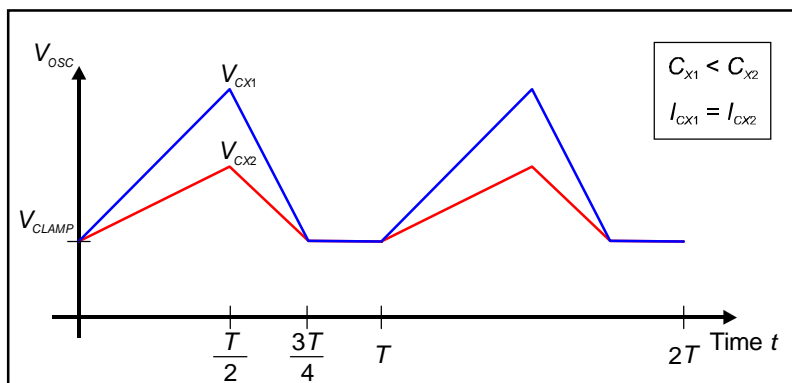

Figure 3: integrator voltage curve

where ΔV_{OSC} is the difference between the thresholds ($V_{OSC,HIGH}$ and $V_{OSC,LOW}$) of the internal reference oscillator. ΔV_{OSC} is defined via internal resistances and has a value of 2.1V @ $V_{CC} = 5V$. The oscillator voltage curve is shown in Figure 2.

Capacitive integrators

The built-in capacitive integrators function in much the same way as the reference oscillator. One difference lies in the discharge time, which here is twice as long as the charge-up period. Furthermore, the discharge voltage is clamped to an internal fixed voltage, V_{CLAMP} . The signal voltage of capacitances C_{X1} and C_{X2} is outlined in Figure 3.

The capacitive integrator current I_{CX} is set by external resistance R_{CX} and reference voltage V_M :

$$I_{CX} = \frac{V_M}{R_{CX}}$$

Capacitance C_X is charged up to maximum voltage V_{CX} and can be calculated as follows:

$$V_{CX} = \frac{I_{CX}}{2 \cdot f_{OSC} \cdot (C_X + C_{X,PAR,INT} + C_{X,PAR,EXT})} + V_{CLAMP}$$

The two voltages across capacitances C_{X1} and C_{X2} are subtracted from one another. Applied to the reference voltage V_M the resulting differential voltage is:

$$V_{CX,DIFF} = (V_{CX1} - V_{CX2}) + V_M$$

Differential voltage $V_{CX,DIFF}$ is applied to a second-order low-pass filter. The 3dB cut-off frequencies of the two stages, f_{C1} and f_{C2} , are defined by external capacitances C_{L1} and C_{L2} and internal resistances R_{01} and R_{02} (typically 20k Ω). The 3dB cut-off frequencies must be selected with regard to the reference oscillator frequency f_{OSC} and the required detection frequency of the overall sensor system (f_{DET}). Here, the following inequality of the various frequencies must be adhered to:

$$f_{DET} < f_C \ll f_{OSC}$$

The external capacitance for the required cut-off frequency f_C amounts to

$$C_L = \frac{1}{2\pi \cdot R_0 \cdot f_C}$$

The output signal of the low-pass filter tracing the ideal curve shown in Figure 3 is calculated as

$$V_{LPOUT} = V_{DIFF,0} + V_M \quad \text{with} \quad V_{DIFF,0} = \frac{3}{8} \cdot (V_{CX1} - V_{CX2})$$

Should the differential output voltage $V_{DIFF,0}$ be too small it can be amplified using the non-inverting output amplifier, with the degree of amplification being determined by resistances R_{L1} and R_{L2} .

The amplification of the stage is

$$G_{LP} = 1 + \frac{R_{L1}}{R_{L2}}$$

It thus follows that the output signal of the low-pass stage is

$$V_{LPOUT} = V_{DIFF} + V_M \quad \text{with} \quad V_{DIFF} = G_{LP} \cdot V_{DIFF,0} = G_{LP} \cdot \frac{3}{8} \cdot (V_{CX1} - V_{CX2})$$

In order to reduce the number of external components needed for the sensor system a temperature acquisition sensor was integrated. With the aid of a processor, this sensor can be used to compensate for the temperature error of the entire sensor system, for example.

FUNCTIONAL DIAGRAM

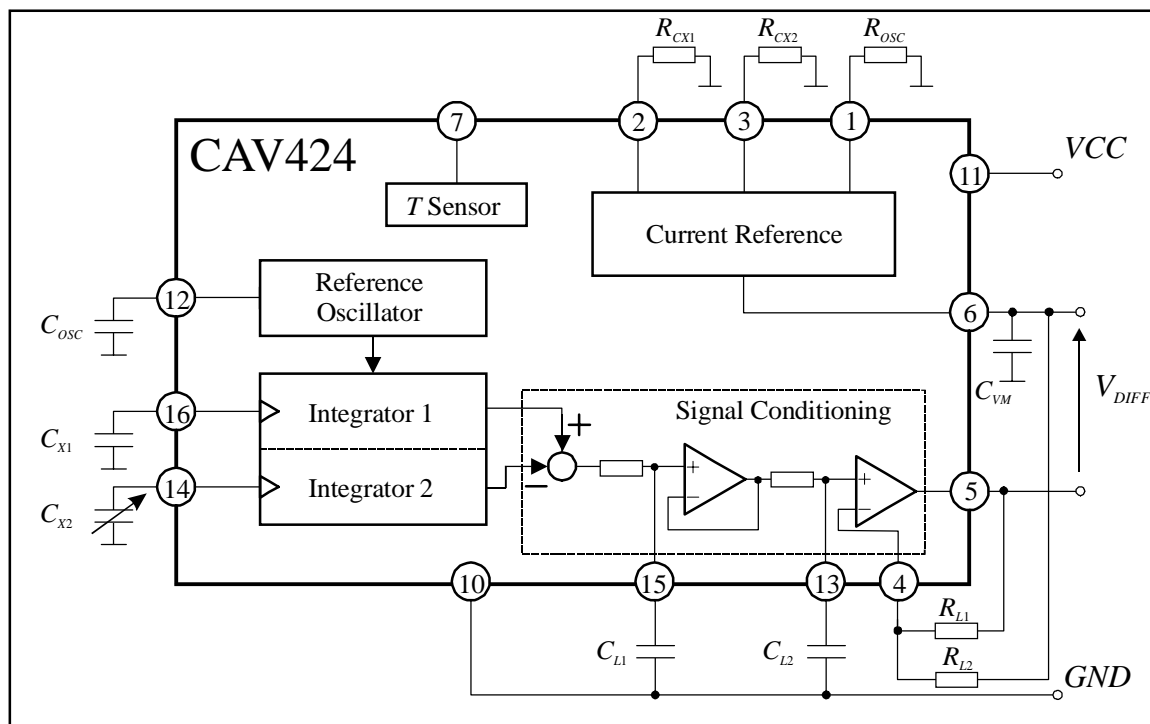

Figure 4: functional diagram CAV424

Adjustment:

The zero-adjustment is made by the resistors R_{CX1} or R_{CX2} for the case that the varying capacitance C_{X2} has nearly the same (and its smallest) value as the fixed capacitance C_{X1} (reference capacitance). Therefore one of this resistors is varied until the differential voltage

$$V_{DIFF} = V_{LPOUT} - V_M$$

is zero:

$$V_{DIFF} = 0$$

Application Example:

The following values are given:

- fixed capacitance C_{X1} : 50pF
- varying capacitance C_{X2} : 50 ... 100pF

Calculation:

With the equations given in the boundary conditions, the following values for the devices can be calculated:

- C_{OSC} : 80pF
- C_{L1} : 10nF
- C_{L2} : 10nF

PINOUT

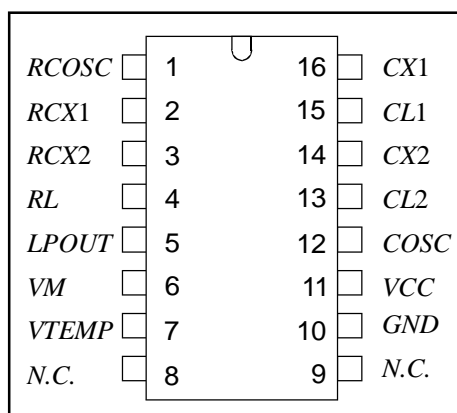

Figure 5: pinout CAV424

PIN	NAME	DESCRIPTION
1	RCOSC	Current Definition of Ref. Oscillator
2	RCX1	Current Adjustment of Cap. Integrator 1
3	RCX2	Current Adjustment of Cap. Integrator 2
4	RL	Gain Adjustment
5	LPOUT	Output
6	VM	Reference Voltage 2.5V
7	VTEMP	Temperature Sensor
8	N.C.	Not Connected
9	N.C.	Not Connected
10	GND	IC Ground
11	VCC	Supply Voltage
12	COSC	Capacitor of Reference Oscillator
13	CL2	Corner Frequency of Lowpass 2
14	CX2	Integrator Capacitor 2
15	CL1	Corner Frequency of Lowpass 1
16	CX1	Integrator Capacitor 1

DELIVERY

The CAV424 is available in version:

- 16 pin DIL
- SO 16 (n) (maximum power dissipation $P_D = 300\text{mW}$)
- Dice on 5" blue foil

The information provided herein is believed to be reliable; however, Analog Microelectronics assumes no responsibility for inaccuracies or omissions. Analog Microelectronics assumes no responsibility for the use of this information, and all use of such information shall be entirely at the user's own risk. Prices and specifications are subject to change without notice. No patent rights or licences to any of the circuits described herein are implied or granted to any third party. Analog Microelectronics does not authorise or warrant any Analog Microelectronics product use in life support devices and/or systems.