



June 1999

## ADC1001 10-Bit $\mu$ P Compatible A/D Converter

### General Description

The ADC1001 is a CMOS, 10-bit successive approximation A/D converter. The 20-pin ADC1001 is pin compatible with the ADC0801 8-bit A/D family. The 10-bit data word is read in two 8-bit bytes, formatted left justified and high byte first. The six least significant bits of the second byte are set to zero, as is proper for a 16-bit word.

Differential inputs provide low frequency input common mode rejection and allow offsetting the analog range of the converter. In addition, the reference input can be adjusted enabling the conversion of reduced analog ranges with 10-bit resolution.

### Key Specifications

- Resolution 10 bits
- Linearity error  $\pm 1$  LSB
- Conversion time 200 $\mu$ S

### Features

- ADC1001 is pin compatible with ADC0801 series 8-bit A/D converters
- Compatible with NSC800 and 8080  $\mu$ P derivatives—no interfacing logic needed
- Easily interfaced to 6800  $\mu$ P derivatives
- Differential analog voltage inputs
- Logic inputs and outputs meet both MOS and TTL voltage level specifications
- Works with 2.5V (LM336) voltage reference
- On-chip clock generator
- 0V to 5V analog input voltage range with single 5V supply
- Operates ratiometrically or with 5  $V_{DC}$ , 2.5  $V_{DC}$ , or analog span adjusted voltage reference
- 0.3" standard width 20-pin DIP package

### Connection Diagram

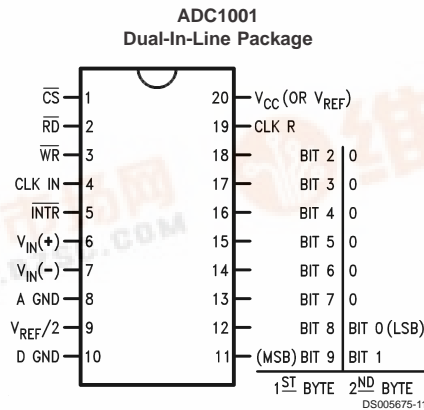

### Ordering Information

Temperature Range	0°C to +70°C	-40°C to +85°C
Order Number	ADC1001CCJ-1	ADC1001CCJ
Package Outline	J20A	J20A



## Absolute Maximum Ratings (Notes 1, 2)

If Military/Aerospace specified devices are required, please contact the National Semiconductor Sales Office/Distributors for availability and specifications.

Supply Voltage ( $V_{CC}$ ) (Note 3)	6.5V
Logic Control Inputs	-0.3V to +18V
Voltage at Other Inputs and Outputs	-0.3V to ( $V_{CC}+0.3V$ )
Storage Temperature Range	-65°C to +150°C
Package Dissipation at $T_A=25^\circ\text{C}$	875 mW

Lead Temp. (Soldering, 10 seconds)	300°C
ESD Susceptibility (Note 10)	800V

## Operating Conditions (Notes 1, 2)

Temperature Range	$T_{MIN} \leq T_A \leq T_{MAX}$
ADC1001CCJ	-40°C $\leq T_A \leq$ +85°C
ADC1001CCJ-1	0°C $\leq T_A \leq$ +70°C
Range of $V_{CC}$	4.5 $V_{DC}$ to 6.3 $V_{DC}$

## Converter Characteristics

**Converter Specifications:**  $V_{CC}=5 V_{DC}$ ,  $V_{REF}/2=2.500 V_{DC}$ ,  $T_{MIN} \leq T_A \leq T_{MAX}$ , and  $f_{CLK}=410$  kHz unless otherwise specified.

Parameter	Conditions	Min	Typ	Max	Units
Linearity Error				$\pm 1$	LSB
Zero Error				$\pm 2$	LSB
Full-Scale Error				$\pm 2$	LSB
Total Ladder Resistance (Note 9)	Input Resistance at Pin 9	2.2	4.8		K $\Omega$
Analog Input Voltage Range	(Note 4) V(+) or V(-)	GND-0.05		$V_{CC}+0.05$	$V_{DC}$
DC Common-Mode Error	Over Analog Input Voltage Range		$\pm 1/8$		LSB
Power Supply Sensitivity	$V_{CC}=5 V_{DC} \pm 5\%$ Over Allowed $V_{IN}(+)$ and $V_{IN}(-)$ Voltage Range (Note 4)		$\pm 1/8$		LSB

## AC Electrical Characteristics

**Timing Specifications:**  $V_{CC}=5 V_{DC}$  and  $T_A=25^\circ\text{C}$  unless otherwise specified.

Symbol	Parameter	Conditions	Min	Typ	Max	Units
$T_c$	Conversion Time	(Note 5)	80		90	1/ $f_{CLK}$
		$f_{CLK}=410$ kHz	195		220	$\mu\text{s}$
$f_{CLK}$	Clock Frequency	(Note 8)	100		1260	kHz
		Clock Duty Cycle	40		60	%
CR	Conversion Rate In Free-Running Mode	$\overline{INTR}$ tied to $\overline{WR}$ with $\overline{CS}=0 V_{DC}$ , $f_{CLK}=410$ kHz			4600	conv/s
$t_{W(WR)L}$	Width of $\overline{WR}$ Input (Start Pulse Width)	$\overline{CS}=0 V_{DC}$ (Note 6)	150			ns
$t_{ACC}$	Access Time (Delay from Falling Edge of $\overline{RD}$ to Output Data Valid)	$C_L=100$ pF		170	300	ns
$t_{1H}, t_{0H}$	TRI-STATE® Control (Delay from Rising Edge of $\overline{RD}$ to Hi-Z State)	$C_L=10$ pF, $R_L=10k$ (See TRI-STATE Test Circuits)		125	200	ns
$t_{WI}, t_{RI}$	Delay from Falling Edge of $\overline{WR}$ or $\overline{RD}$ to Reset of $\overline{INTR}$			300	450	ns
$t_{1rs}$	$\overline{INTR}$ to 1st Read Set-Up Time		550	400		ns
$C_{IN}$	Input Capacitance of Logic Control Inputs			5	7.5	pF
$C_{OUT}$	TRI-STATE Output Capacitance (Data Buffers)			5	7.5	pF

## DC Electrical Characteristics

The following specifications apply for  $V_{CC}=5 V_{DC}$  and  $T_{MIN} \leq T_A \leq T_{MAX}$ , unless otherwise specified.

Symbol	Parameter	Conditions	Min	Typ	Max	Units
<b>CONTROL INPUTS</b> [Note: CLK IN is the input of a Schmitt trigger circuit and is therefore specified separately]						
$V_{IN(1)}$	Logical "1" Input Voltage (Except CLK IN)	$V_{CC}=5.25 V_{DC}$	2.0		15	$V_{DC}$
$V_{IN(0)}$	Logical "0" Input Voltage (Except CLK IN)	$V_{CC}=4.75 V_{DC}$			0.8	$V_{DC}$
$I_{IN(1)}$	Logical "1" Input Current (All Inputs)	$V_{IN}=5 V_{DC}$		0.005	1	$\mu A_{DC}$
$I_{IN(0)}$	Logical "0" input Current (All Inputs)	$V_{IN}=0 V_{DC}$	-1	-0.005		$\mu A_{DC}$
<b>CLOCK IN</b>						
$V_{T+}$	CLK IN Positive Going Threshold Voltage		2.7	3.1	3.5	$V_{DC}$
$V_{T-}$	CLK IN Negative Going Threshold Voltage		1.5	1.8	2.1	$V_{DC}$
$V_H$	CLK IN Hysteresis ( $V_{T+}$ )-( $V_{T-}$ )		0.6	1.3	2.0	$V_{DC}$
<b>OUTPUTS AND INTR</b>						
$V_{OUT(0)}$	Logical "0" Output Voltage	$I_{OUT}=1.6 mA, V_{CC}=4.75 V_{DC}$			0.4	$V_{DC}$
$V_{OUT(1)}$	Logical "1" Output Voltage	$I_O=-360 \mu A, V_{CC}=4.75 V_{DC}$ $I_O=-10 \mu A, V_{CC}=4.75 V_{DC}$	2.4 4.5			$V_{DC}$ $V_{DC}$
$I_{OUT}$	TRI-STATE Disabled Output Leakage (All Data Buffers)	$V_{OUT}=0.4 V_{DC}$ $V_{OUT}=5 V_{DC}$		0.1 0.1	-100 3	$\mu A_{DC}$ $\mu A_{DC}$
$I_{SOURCE}$		$V_{OUT}$ Short to GND, $T_A=25^\circ C$	4.5	6		$mA_{DC}$
$I_{SINK}$		$V_{OUT}$ Short to $V_{CC}$ , $T_A=25^\circ C$	9.0	16		$mA_{DC}$
<b>POWER SUPPLY</b>						
$I_{CC}$	Supply Current (Includes Ladder Current)	$f_{CLK}=410 kHz,$ $V_{REF}/2=NC, T_A=25^\circ C$ and $\overline{CS}=1$		2.5	5.0	mA

**Note 1:** Absolute Maximum Ratings indicate limits beyond which damage to the device may occur. DC and AC electrical specifications do not apply when operating the device beyond its specified operating conditions.

**Note 2:** All voltages are measured with respect to GND, unless otherwise specified. The separate A GND point should always be wired to the D GND.

**Note 3:** A zener diode exists, internally, from  $V_{CC}$  to GND and has a typical breakdown voltage of  $7 V_{DC}$ .

**Note 4:** For  $V_{IN(-)} \geq V_{IN(+)}$  the digital output code will be all zeros. Two on-chip diodes are tied to each analog input (see Block Diagram) which will forward conduct for analog input voltages one diode drop below ground or one diode drop greater than the  $V_{CC}$  supply. Be careful, during testing at low  $V_{CC}$  levels (4.5V), as high level analog inputs (5V) can cause this input diode to conduct — especially at elevated temperatures, and cause errors for analog inputs near fullscale. The spec allows 50 mV forward bias of either diode. This means that as long as the analog  $V_{IN}$  does not exceed the supply voltage by more than 50 mV, the output code will be correct. To achieve an absolute 0  $V_{DC}$  to 5  $V_{DC}$  input voltage range will therefore require a minimum supply voltage of  $4.950 V_{DC}$  over temperature variations, initial tolerance and loading.

**Note 5:** With an asynchronous start pulse, up to 8 clock periods may be required before the internal clock phases are proper to start the conversion process. The start request is internally latched, see *Figure 3*.

**Note 6:** The  $\overline{CS}$  input is assumed to bracket the  $\overline{WR}$  strobe input and therefore timing is dependent on the  $\overline{WR}$  pulse width. An arbitrarily wide pulse width will hold the converter in a reset mode and the start of conversion is initiated by the low to high transition of the  $\overline{WR}$  pulse (see Timing Diagrams).

**Note 7:** All typical values are for  $T_A=25^\circ C$ .

**Note 8:** Accuracy is guaranteed at  $f_{CLK}=410 kHz$ . At higher clock frequencies accuracy can degrade.

**Note 9:** The  $V_{REF}/2$  pin is the center point of a two resistor divider (each resistor is  $2.4k\Omega$ ) connected from  $V_{CC}$  to ground. Total ladder input resistance is the sum of these two equal resistors.

**Note 10:** Human body model, 100 pF discharged through a  $1.5 k\Omega$  resistor.

## Typical Performance Characteristics

**Logic Input Threshold Voltage vs Supply Voltage**

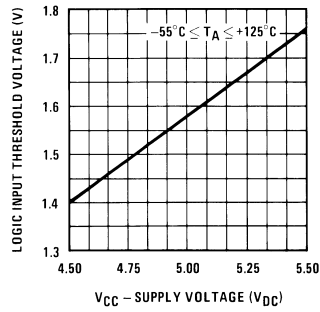

DS005675-14

**Delay From Falling Edge of RD to Output Data Valid vs Load Capacitance**

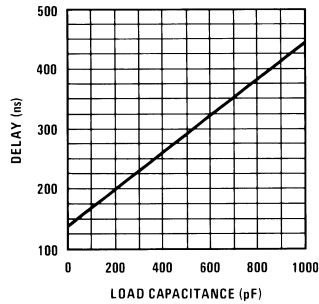

DS005675-15

**CLK IN Schmitt Trip Levels vs Supply Voltage**

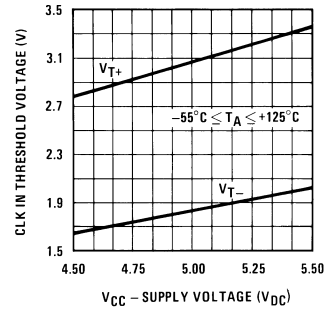

DS005675-16

**Output Current vs Temperature**

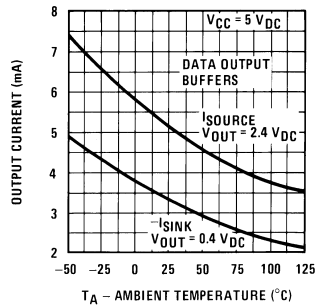

DS005675-17

## TRI-STATE Test Circuits and Waveforms

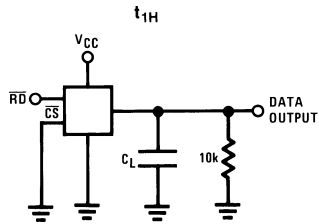

DS005675-3

$t_r=20$  ns

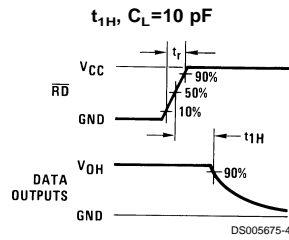

DS005675-4

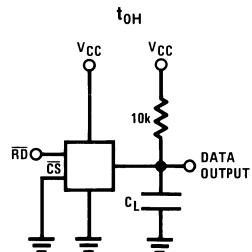

DS005675-5

$t_r=20$  ns

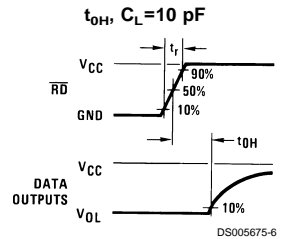

DS005675-6

## TRI-STATE Test Circuits and Waveforms (Continued)

### Timing Diagrams

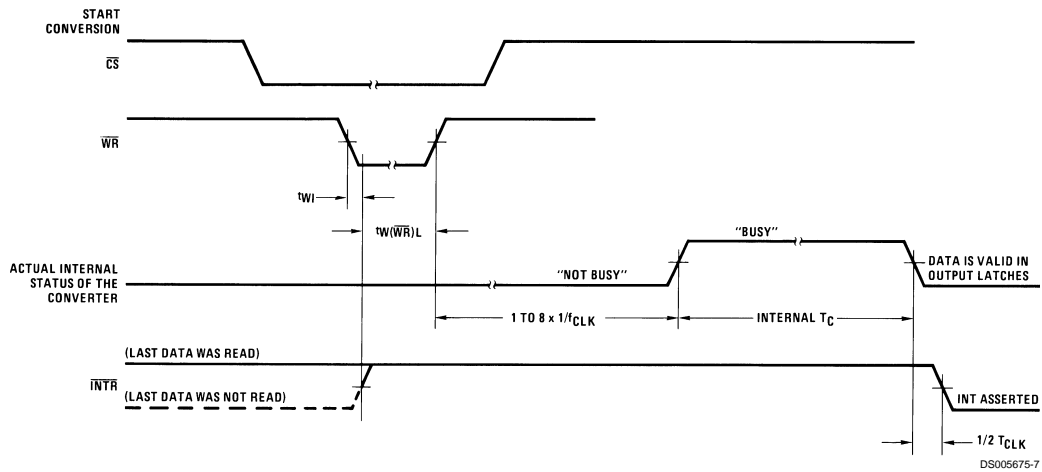

### Output Enable and Reset $\overline{INTR}$

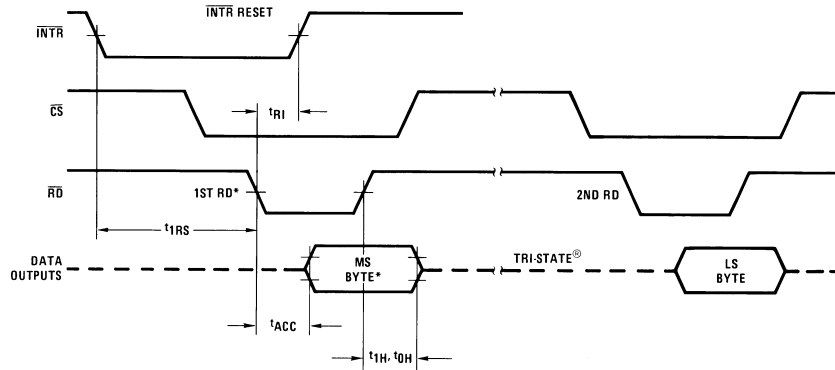

\*All timing is measured from the 50% voltage points.

## Timing Diagrams (Continued)

### Byte Sequencing For The 20-Pin ADC1001

Byte Order	8-Bit Data Bus Connection							
	DB7	DB6	DB5	DB4	DB3	DB2	DB1	DB0
1st	MSB Bit 9	Bit 8	Bit 7	Bit 6	Bit 5	Bit 4	Bit 3	Bit 2
2nd	Bit 1	LSB Bit 0	0	0	0	0	0	0

### Functional Description

The ADC1001 uses an advanced potentiometric resistive ladder network. The analog inputs, as well as the taps of this ladder network, are switched into a weighted capacitor array. The output of this capacitor array is the input to a sampled data comparator. This comparator allows the successive approximation logic to match the analog difference input voltage  $[V_{IN(+)} - V_{IN(-)}]$  to taps on the R network. The most significant bit is tested first and after 10 comparisons (80 clock cycles) a digital 10-bit binary code (all "1"s=full-scale) is transferred to an output latch and then an interrupt is asserted ( $\overline{INTR}$  makes a high-to-low transition). The device may be operated in the free-running mode by connecting  $\overline{INTR}$  to the  $\overline{WR}$  input with  $\overline{CS} = 0$ . To ensure start-up under all possible conditions, an external  $\overline{WR}$  pulse is required during the first power-up cycle. A conversion in process can be interrupted by issuing a second start command.

On the high-to-low transition of the  $\overline{WR}$  input the internal SAR latches and the shift register stages are reset. As long as the  $\overline{CS}$  input and  $\overline{WR}$  input remain low, the A/D will remain in a reset state. Conversion will start from 1 to 8 clock periods after at least one of these inputs makes a low-to-high transition.

A functional diagram of the A/D converter is shown in Figure 3. All of the inputs and outputs are shown and the major logic control paths are drawn in heavier weight lines.

The conversion is initialized by taking  $\overline{CS}$  and  $\overline{WR}$  simultaneously low. This sets the start flip-flop (F/F) and the resulting "1" level resets the 8-bit shift register, resets the Interrupt ( $\overline{INTR}$ ) F/F and inputs a "1" to the D flop, F/F1, which is at the input end of the 10-bit shift register. Internal clock signals then transfer this "1" to the Q output of F/F1. The AND gate, G1, combines this "1" output with a clock signal to provide a reset signal to the start F/F. If the set signal is no longer present (either  $\overline{WR}$  or  $\overline{CS}$  is a "1") the start F/F is reset and the 10-bit shift register then can have the "1" clocked in, which allows the conversion process to continue. If the set signal were to still be present, this reset pulse would have no effect and the 10-bit shift register would continue to be held in the reset mode. This logic therefore allows for wide  $\overline{CS}$  and  $\overline{WR}$  signals and the converter will start after at least one of these signals returns high and the internal clocks again provide a reset signal for the start F/F.

After the "1" is clocked through the 10-bit shift register (which completes the SAR search) it causes the new digital word to transfer to the TRI-STATE output latches. When this XFER signal makes a high-to-low transition the one shot fires, setting the  $\overline{INTR}$  F/F. An inverting buffer then supplies the  $\overline{INTR}$  output signal.

Note that this  $\overline{SET}$  control of the  $\overline{INTR}$  F/F remains low for approximately 400 ns. If the data output is continuously enabled ( $\overline{CS}$  and  $\overline{RD}$  both held low), the  $\overline{INTR}$  output will still signal the end of the conversion (by a high-to-low transition),

because the  $\overline{SET}$  input can control the Q output of the  $\overline{INTR}$  F/F even though the RESET input is constantly at a "1" level. This  $\overline{INTR}$  output will therefore stay low for the duration of the  $\overline{SET}$  signal.

When data is to be read, the combination of both  $\overline{CS}$  and  $\overline{RD}$  being low will cause the  $\overline{INTR}$  F/F to be reset and the TRI-STATE output latches will be enabled.

#### Zero and Full-Scale Adjustment

Zero error can be adjusted as shown in Figure 1.  $V_{IN(+)}$  is forced to +2.5 mV (+1/2 LSB) and the potentiometer is adjusted until the digital output code changes from 00 0000 0000 to 00 0000 0001.

Full-scale is adjusted as shown in Figure 2, with the  $V_{REF/2}$  input. With  $V_{IN (+)}$  forced to the desired full-scale voltage less 1/2 LSBs ( $V_{FS} - 1/2$  LSBs),  $V_{REF/2}$  is adjusted until the digital output code changes from 11 1111 1110 to 11 1111 1111.

## Functional Description (Continued)

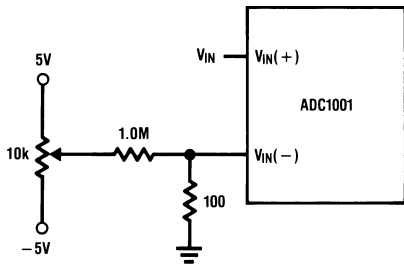

DS005675-9

**Note 11:**  $V_{IN(-)}$  should be biased so that  $V_{IN(-)} \geq -0.05V$  when potentiometer wiper is set at most negative voltage position.

FIGURE 1. Zero Adjust Circuit

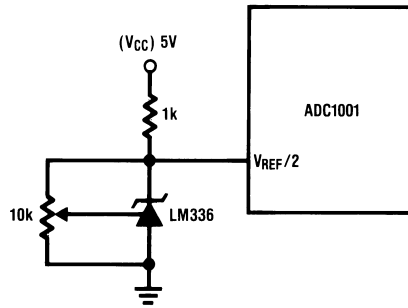

DS005675-10

FIGURE 2. Full-Scale Adjust

## Typical Application

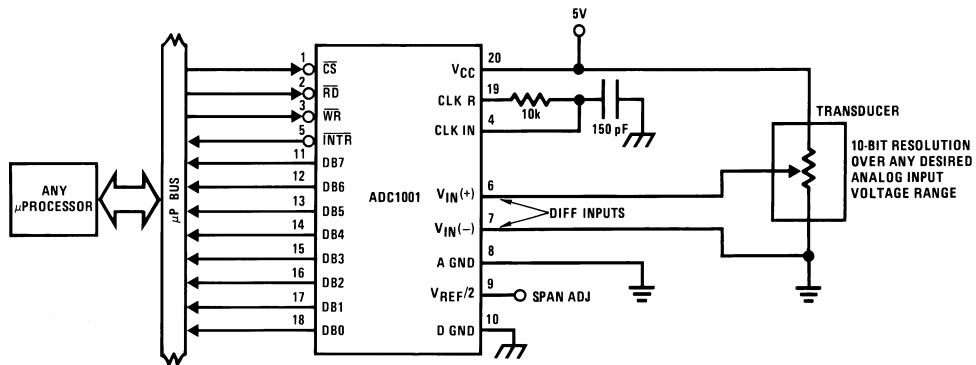

DS005675-1

## Block Diagram

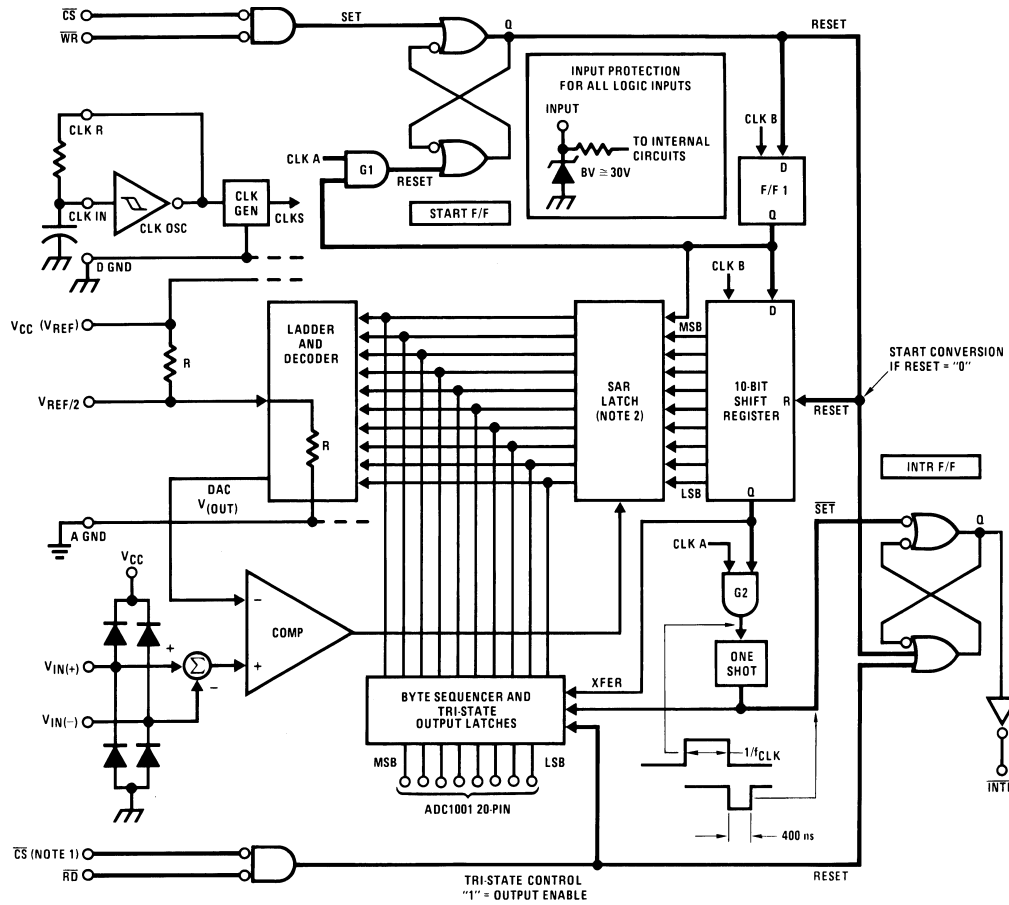

Note 12:  $\overline{CS}$  shown twice for clarity.

Note 13: SAR= Successive Approximation Register.

FIGURE 3.

DS005675-13



**Physical Dimensions** inches (millimeters) unless otherwise noted

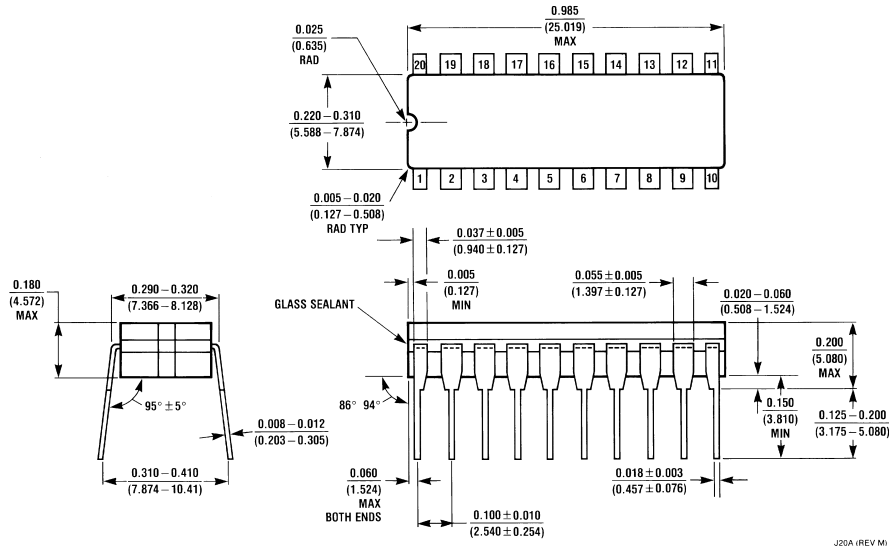

**Cavity Dual-In-Line Package (J) (Side Brazed)**  
**Order Number ADC1001CCJ or ADC1001CCJ-1**  
**NS Package Number J20A**

**LIFE SUPPORT POLICY**

NATIONAL'S PRODUCTS ARE NOT AUTHORIZED FOR USE AS CRITICAL COMPONENTS IN LIFE SUPPORT DEVICES OR SYSTEMS WITHOUT THE EXPRESS WRITTEN APPROVAL OF THE PRESIDENT AND GENERAL COUNSEL OF NATIONAL SEMICONDUCTOR CORPORATION. As used herein:

1. Life support devices or systems are devices or systems which, (a) are intended for surgical implant into the body, or (b) support or sustain life, and whose failure to perform when properly used in accordance with instructions for use provided in the labeling, can be reasonably expected to result in a significant injury to the user.
2. A critical component is any component of a life support device or system whose failure to perform can be reasonably expected to cause the failure of the life support device or system, or to affect its safety or effectiveness.

**National Semiconductor Corporation**  
Americas  
Tel: 1-800-272-9959  
Fax: 1-800-737-7018  
Email: support@nsc.com

**National Semiconductor Europe**  
Fax: +49 (0) 1 80-530 85 86  
Email: europe.support@nsc.com  
Deutsch Tel: +49 (0) 1 80-530 85 85  
English Tel: +49 (0) 1 80-532 78 32  
Français Tel: +49 (0) 1 80-532 93 58  
Italiano Tel: +49 (0) 1 80-534 16 80

**National Semiconductor Asia Pacific Customer Response Group**  
Tel: 65-2544466  
Fax: 65-2504466  
Email: sea.support@nsc.com

**National Semiconductor Japan Ltd.**  
Tel: 81-3-5639-7560  
Fax: 81-3-5639-7507

www.national.com