



HCC/HCF4009UB HCC/HCF4010B

HEX BUFFER/CONVERTERS

4009UB—INVERTING TYPE 4010B—NON INVERTING TYPE

- CMOS TO DTL/TTL HEX CONVERTER
- HIGH-TO-LOW LEVEL LOGIC CONVERSION
- MULTIPLEXER: 1-TO-6 OR 6-TO-1
- HIGH "SINK" AND "SOURCE" CURRENT CAPABILITY
- 5V, 10V AND 15V PARAMETRIC RATINGS
- MAXIMUM INPUT CURRENT OF 100 μ A AT 18V OVER FULL
- PACKAGE AND TEMPERATURE RANGE; 100nA AT 18V AND 25°C
- 100% TESTED FOR QUIESCENT CURRENT AT 20V
- MEETS ALL REQUIREMENTS OF JEDEC TENTATIVE STANDARD N. 13A, "STANDARD SPECIFICATIONS FOR DESCRIPTION OF B SERIES CMOS DEVICES"

non-inverting Hex Buffer/Converters, respectively. Both devices can be used as CMOS to TTL or DTL logic-level converters, as current "sink" or "source" drivers or as multiplexer (1 to 6).

4049UB and **4050B** are preferred replacements for **4009UB** and **4010B**, respectively, in buffer applications.

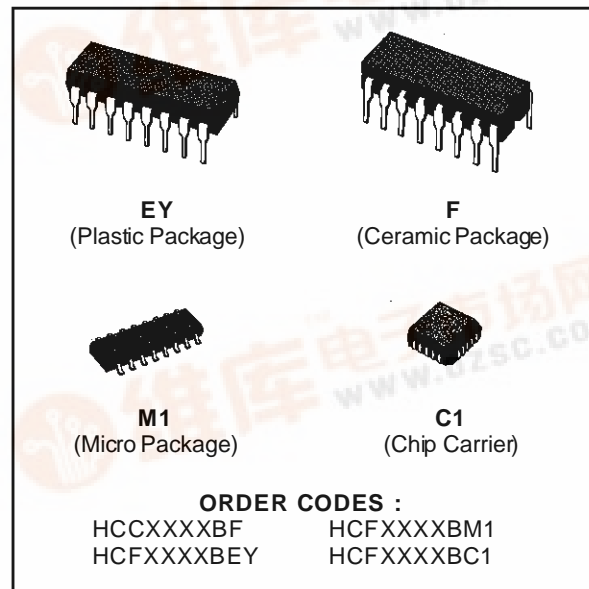

DESCRIPTION

The **HCC4009UB/4010B** (extended temperature range) and the **HCF4009UB/4010B** (intermediate temperature range) are monolithic integrated circuits available in 16-lead dual in line plastic or ceramic packages and plastic micropackage.

The **HCC/HCF4009UB/4010B** are inverting and

PIN CONNECTIONS

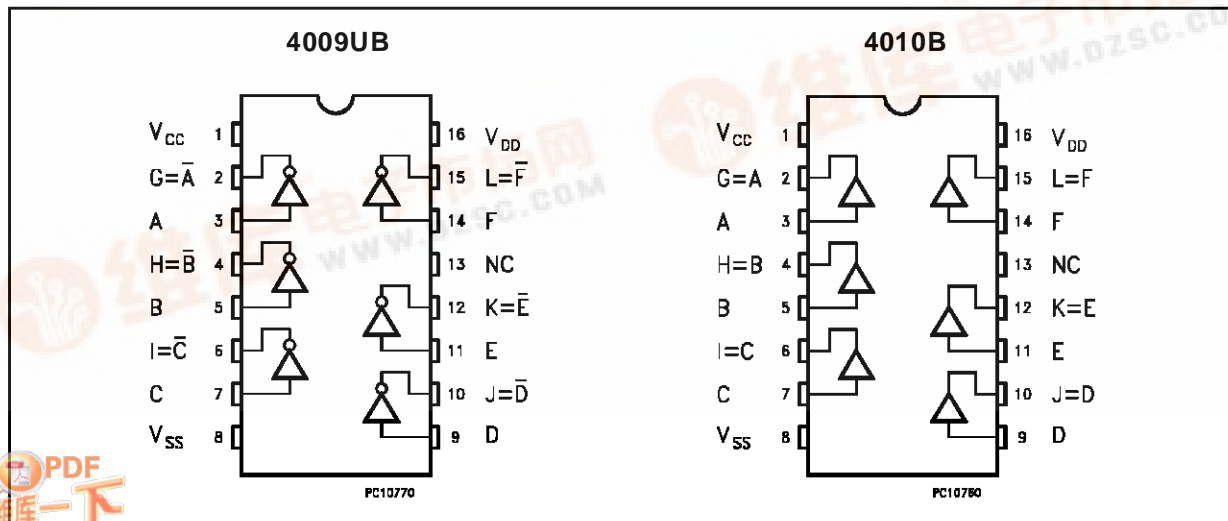

HCC/HCF4009UB HCC/HCF4010B

SCHEMATIC DIAGRAM: COS/MOS TO DTL OR TTL CONVERTER (1 of 6 identical units)

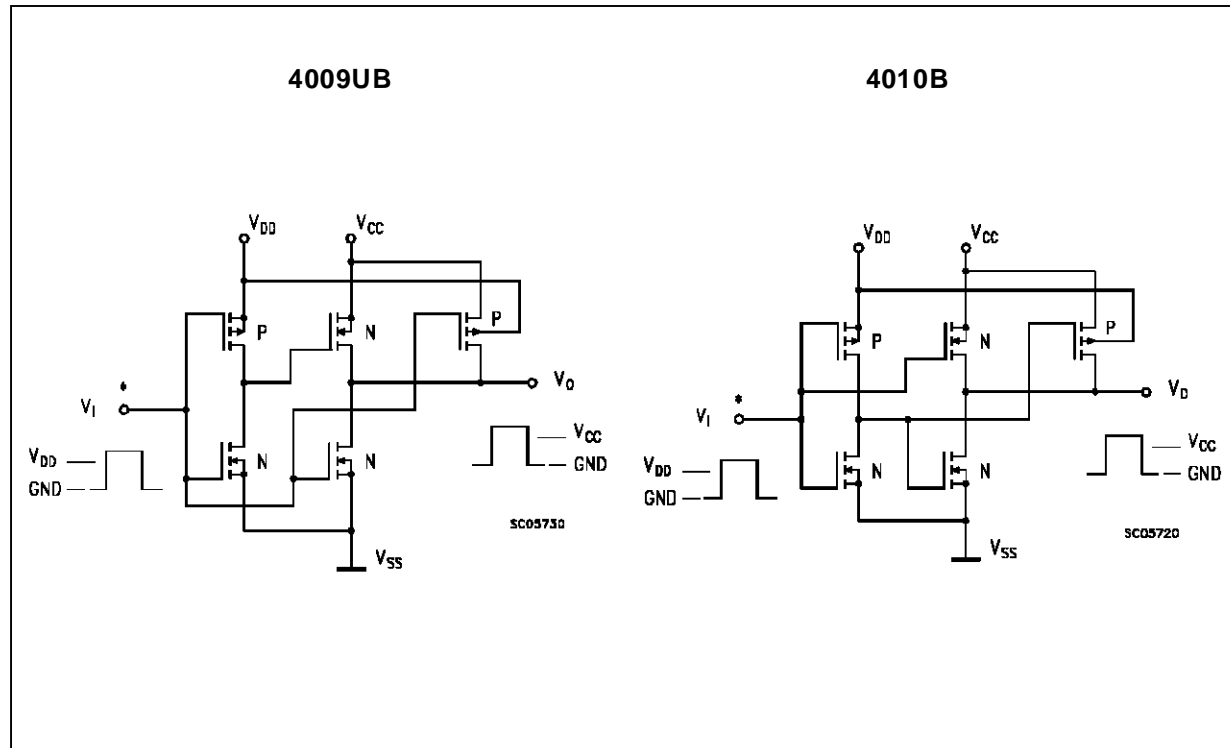

Connect V_{CC} to DTL or TTL supply and V_{DD} to COS/MOS supply

ABSOLUTE MAXIMUM RATING

Symbol	Parameter	Value	Unit
V_{DD} *	Supply Voltage: HCC Types HCF Types	-0.5 to +20	V
		-0.5 to +18	V
V_i	Input Voltage	-0.5 to $V_{DD} + 0.5$	V
I_i	DC Input Current (any one input)	± 10	mA
P_{tot}	Total Power Dissipation (per package) Dissipation per Output Transistor for $T_{op} =$ Full Package Temperature Range	200	mW
		100	mW
T_{op}	Operating Temperature: HCC Types HCF Types	-55 to +125	$^{\circ}\text{C}$
		-40 to +85	$^{\circ}\text{C}$
T_{stg}	Storage Temperature	-65 to +150	$^{\circ}\text{C}$

Stresses above those listed under "Absolute Maximum Ratings" may cause permanent damage to the device. This is a stress rating only and functional operation of the device at these or any other conditions above those indicated in the operational sections of this specification is not implied. Exposure to absolute maximum rating conditions for external periods may affect device reliability.

* All voltage values are referred to V_{SS} pin voltage.

RECOMMENDED OPERATING CONDITIONS

Symbol	Parameter	Value	Unit
V_{DD}	Supply Voltage: HCC Types HCF Types	3 to 18	V
		3 to 15	V
V_i	Input Voltage	0 to V_{DD}	V
T_{op}	Operating Temperature: HCC Types HCF Types	-55 to +125	$^{\circ}\text{C}$
		-40 to +85	$^{\circ}\text{C}$

HCC/HCF4009UB HCC/HCF4010B

STATIC ELECTRICAL CHARACTERISTICS (over recommended operating conditions)

Symbol	Parameter		Test Conditions				Value						Unit	
			V _I (V)	V _O (V)	I _O (μ A)	V _{DD} (V)	T _{LOW} *		25 °C			T _{HIGH} *		
							Min.	Max.	Min.	Typ.	Max.	Min.		Max.
I _L	Quiescent Current	HCC Types	0/5			5		1		0.02	1		30	μ A
			0/10			10		2		0.02	2		60	
			0/15			15		4		0.02	4		120	
		0/20			20		20		0.04	20		600		
		HCF Types	0/5			5		4		0.02	4		30	
			0/10			10		8		0.02	8		60	
0/15				15		16		0.02	16		120			
V _{OH}	Output High Voltage	0/5			5	4.95		4.95			4.95		V	
		0/10			10	9.95		9.95			9.95			
		0/15			15	14.95		14.95			14.95			
V _{OL}	Output Low Voltage	5/0			5		0.05			0.05		0.05	V	
		10/0			10		0.05			0.05		0.05		
		15/0			15		0.05			0.05		0.05		
V _{IH}	Input High Voltage (4009UB)		0.5		5	4		4			4		V	
			1		10	8		8			8			
			1.5		15	12.5		12.5			12.5			
V _{IH}	Input High Voltage (4010B)		4.5		5	3.5		3.5			3.5		V	
			9		10	7		7			7			
			13.5		15	11		11			11			
V _{IL}	Input Low Voltage (4009UB)		4.5		5		1			1		1	V	
			9		10		2			2		2		
			13.5		15		2.5			2.5		2.5		
V _{IL}	Input Low Voltage (4010B)		0.5		5		1.5			1.5		1.5	V	
			1		10		3			3		3		
			1.5		15		4			4		4		
I _{OH}	Output Drive Current	HCC Types	0/5	2.5		5	-1		-0.8	-1.6		-0.58	mA	
			0/5	4.6		5	-0.25		-0.2	-0.4		-0.15		
			0/10	9.5		10	-0.55		-0.45	-0.9		-0.33		
		0/15	13.5		15	-1.65		-1.5	-3		-1.1			
		HCF Types	0/5	2.5		5	-0.9		-0.8	-1.6		-0.65		
			0/5	4.6		5	-0.23		-0.2	-0.4		-0.18		
0/10	9.5			10	-0.5		-0.45	-0.9		-0.38				
0/15	13.5		15	-1.6		-1.5	-3		-1.25					
I _{OL}	Output Sink Current	HCC Types	0/5	0.4		5	3.75		3	4		2.1	mA	
			0/10	0.5		10	10		8	10		5.6		
			0/15	1.5		15	30		24	36		16		
		HCF Types	0/5	0.4		5	3.6		3	4		2.4		
			0/10	0.5		10	0.96		8	10		6.4		
			0/15	1.5		15	40		24	36		1.9		
I _{IH} , I _{IL}	Input Leakage Current	0/18			18		\pm 0.1		\pm 10 ⁻⁵	\pm 0.1		\pm 1	μ A	
C _i	Input Capacitance	4009UB	Any Input						15	22.6				
		4010B							5	7.5			pF	

* T_{LOW} = -55 °C for HCC device; -40 °C for HCF device.

* T_{HIGH} = +125 °C for HCC device; +85 °C for HCF device.

The Noise Margin for both "1" and "0" level is: 1V min. with V_{DD} = 5V, 2V min. with V_{DD} = 10V, 2.5V min. with V_{DD} = 15V

HCC/HCF4009UB HCC/HCF4010B

DYNAMIC ELECTRICAL CHARACTERISTICS ($T_{amb} = 25\text{ }^{\circ}\text{C}$, $C_L = 50\text{ pF}$, $R_L = 200\text{ K}\Omega$, typical temperature coefficient for all V_{DD} values is $03\text{ }^{\circ}\text{C}$, all input rise and fall times = 20 ns)

Symbol	Parameter	Test Conditions			Value			Unit
		V_{DD} (V)	V_i (V)	V_{CC} (V)	Min.	Typ.	Max.	
t_{PLH}	Propagation Delay Time (4009UB)	5	5	5		70	140	ns
		10	10	10		40	80	
		10	10	5		35	70	
		15	15	15		30	60	
		15	15	5		30	60	
t_{PLH}	Propagation Delay Time (4010B)	5	5	5		100	200	ns
		10	10	10		50	100	
		10	10	5		50	100	
		15	15	15		35	70	
t_{PHL}	Propagation Delay Time (4009UB)	5	5	5		30	60	ns
		10	10	10		20	40	
		10	10	5		15	30	
		15	15	15		15	30	
		15	15	5		10	20	
t_{PHL}	Propagation Delay Time (4010B)	5	5	5		65	130	ns
		10	10	10		35	70	
		10	10	5		30	70	
		15	15	15		25	50	
		15	15	5		20	40	
t_{TLH}	Transition Time	5	5	5		150	350	ns
		10	10	10		75	150	
		15	15	15		55	110	
t_{THL}	Transition Time	5	5	5		35	70	ns
		10	10	10		20	40	
		15	15	15		15	30	

Minimum and Maximum Voltage Transfer Characteristics for 4009UB

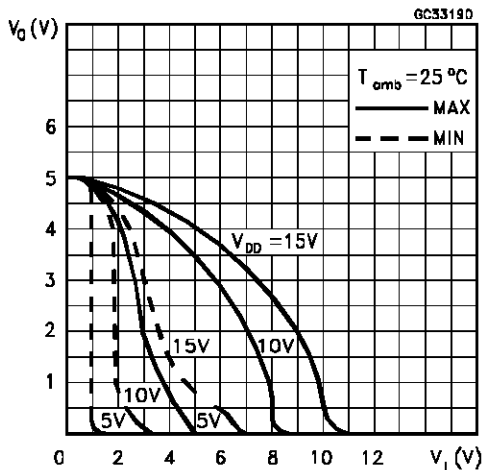

Typical Voltage Transfer Characteristics As a Function of Temperature for 4009UB

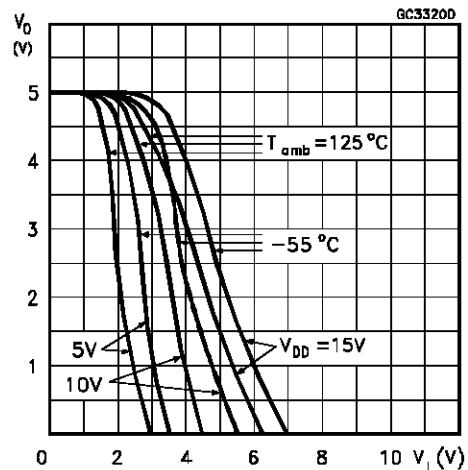

HCC/HCF4009UB HCC/HCF4010B

Minimum and Maximum Voltage Transfer Characteristics for 4010B

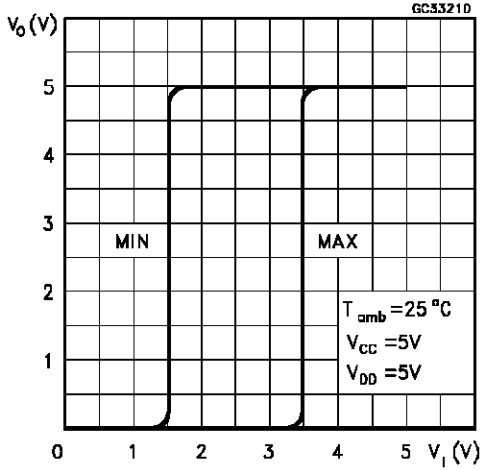

Minimum and Maximum Voltage Transfer Characteristics for 4010B

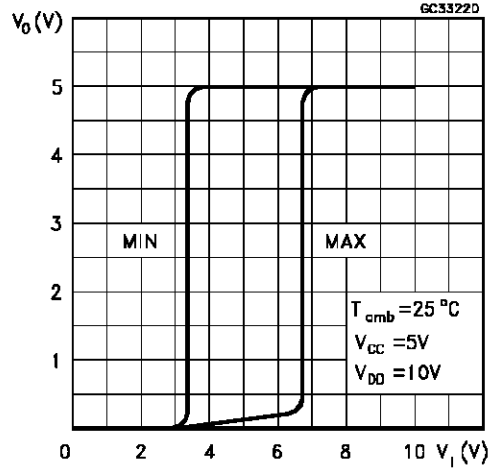

Minimum and Maximum Voltage Transfer Characteristics for 4010B

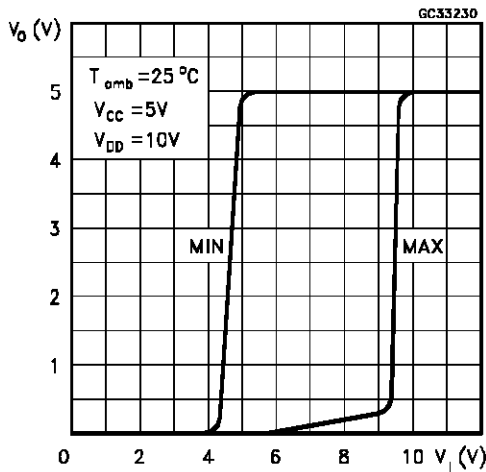

Typical Voltage Transfer Characteristics As a Function of Temperature for 4010B

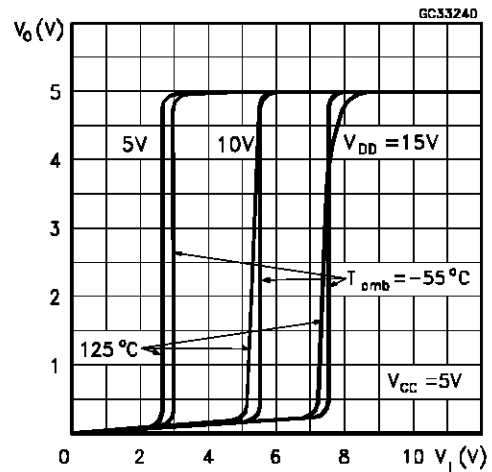

Typical Output Los (sink) Current Characteristics

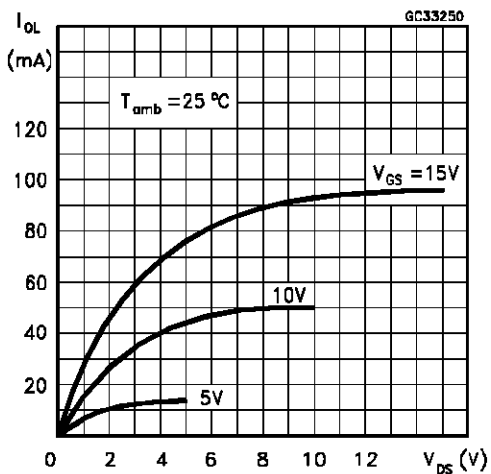

Minimum output Low (sink) Current Characteristics

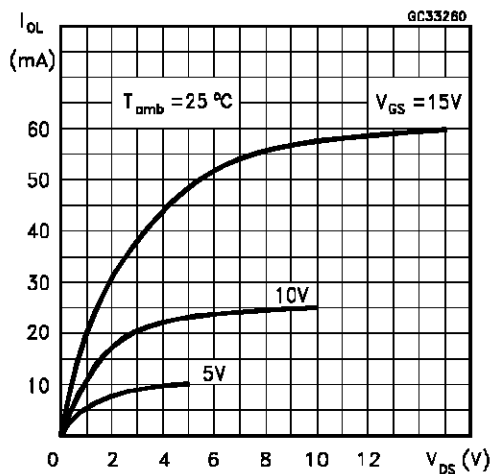

HCC/HCF4009UB HCC/HCF4010B

Typical Output High (source) Current Characteristics

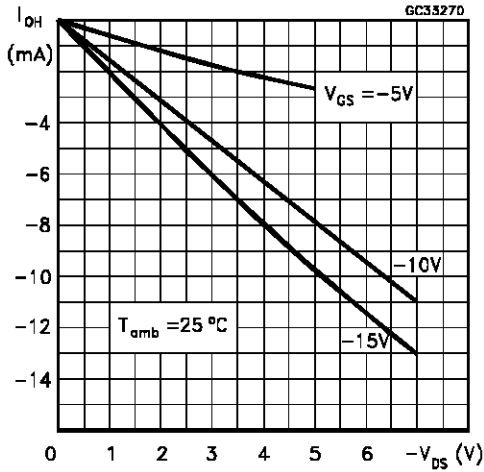

Minimum output High (source) Current Characteristics

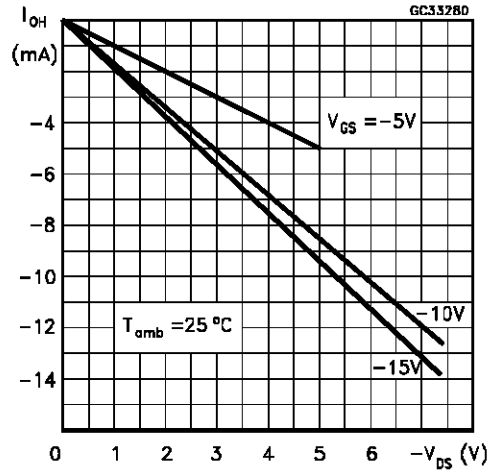

Typical Low to High Propagation Delay Time vs Load Capacitance for 4009UB

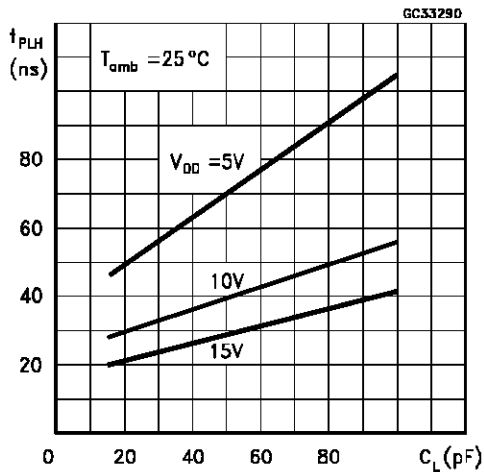

Typical High to Low Propagation Delay Time vs Load Capacitance for 4009UB

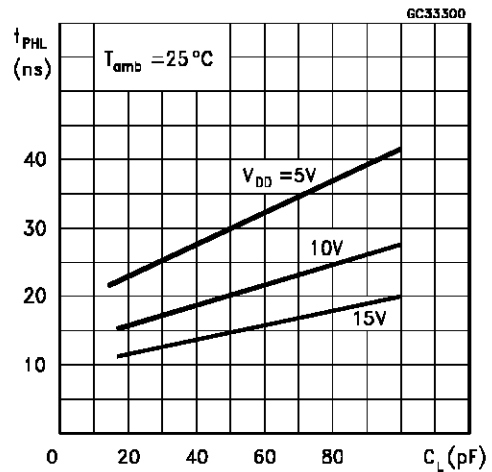

Typical Low to High Propagation Delay Time vs Load Capacitance for 4010B

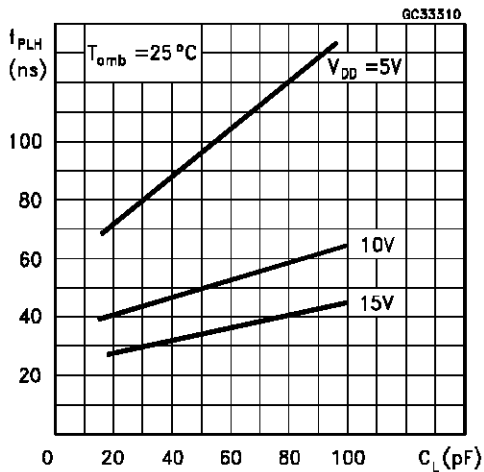

typical High to Low Propagation Delay Time vs Load Capacitance for 4010B

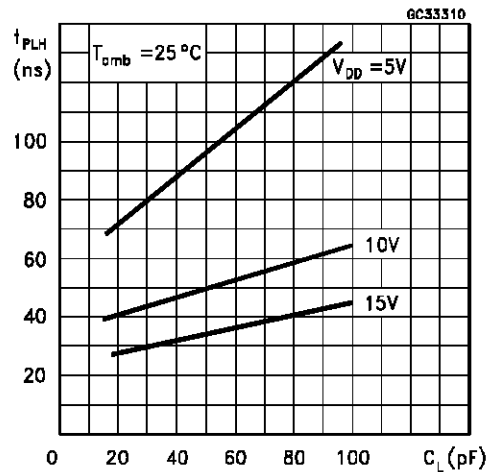

HCC/HCF4009UB HCC/HCF4010B

Typical Low to High Transition Time vs Load Capacitance

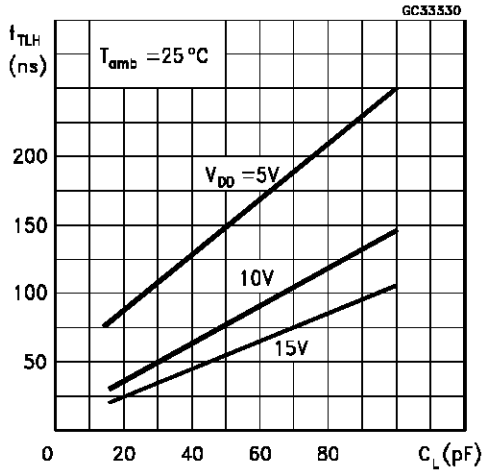

Typical High to Low Transition Time vs Load Capacitance

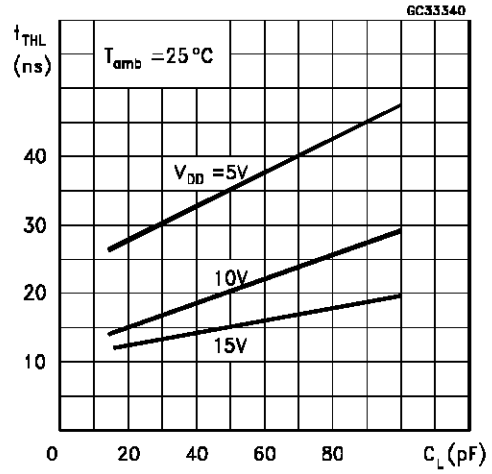

Typical Dissipation Characteristics

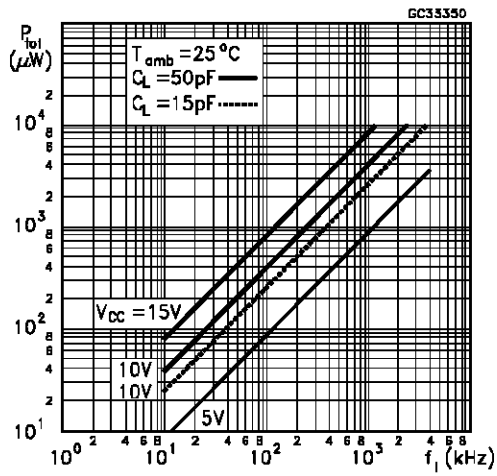

HCC/HCF4009UB HCC/HCF4010B

TEST CIRCUITS

Quiescent Device Current.

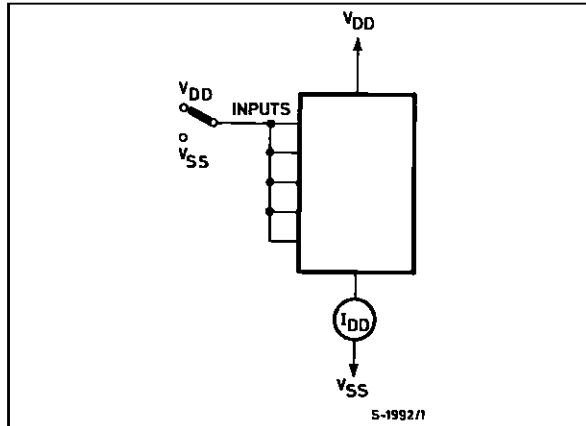

Noise Immunity.

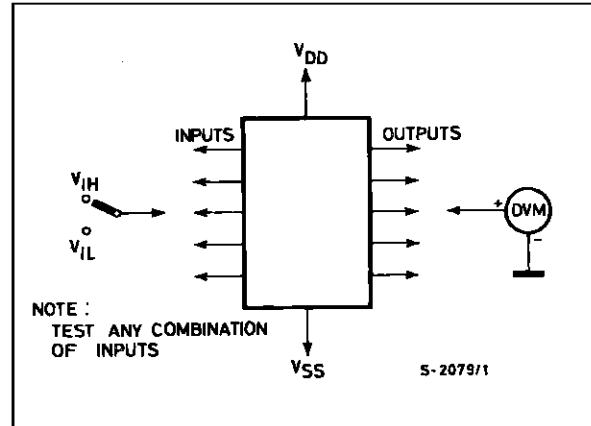

Input Leakage Current.

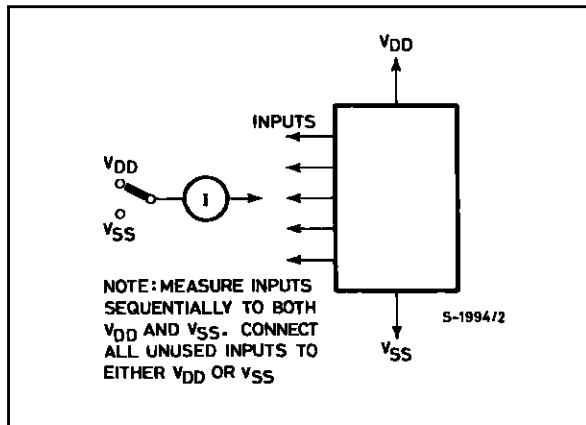

Plastic DIP16 (0.25) MECHANICAL DATA

DIM.	mm			inch		
	MIN.	TYP.	MAX.	MIN.	TYP.	MAX.
a1	0.51			0.020		
B	0.77		1.65	0.030		0.065
b		0.5			0.020	
b1		0.25			0.010	
D			20			0.787
E		8.5			0.335	
e		2.54			0.100	
e3		17.78			0.700	
F			7.1			0.280
I			5.1			0.201
L		3.3			0.130	
Z			1.27			0.050

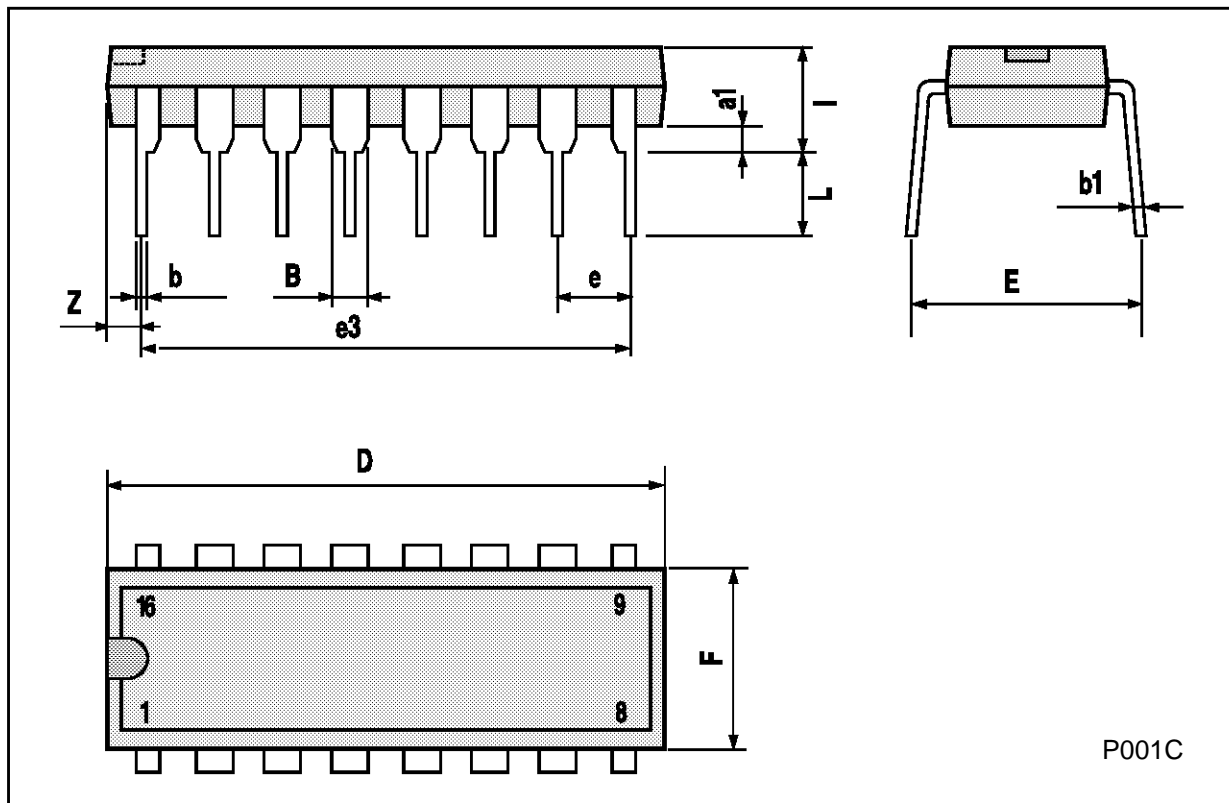

HCC/HCF4009UB HCC/HCF4010B

Ceramic DIP16/1 MECHANICAL DATA

DIM.	mm			inch		
	MIN.	TYP.	MAX.	MIN.	TYP.	MAX.
A			20			0.787
B			7			0.276
D		3.3			0.130	
E	0.38			0.015		
e3		17.78			0.700	
F	2.29		2.79	0.090		0.110
G	0.4		0.55	0.016		0.022
H	1.17		1.52	0.046		0.060
L	0.22		0.31	0.009		0.012
M	0.51		1.27	0.020		0.050
N			10.3			0.406
P	7.8		8.05	0.307		0.317
Q			5.08			0.200

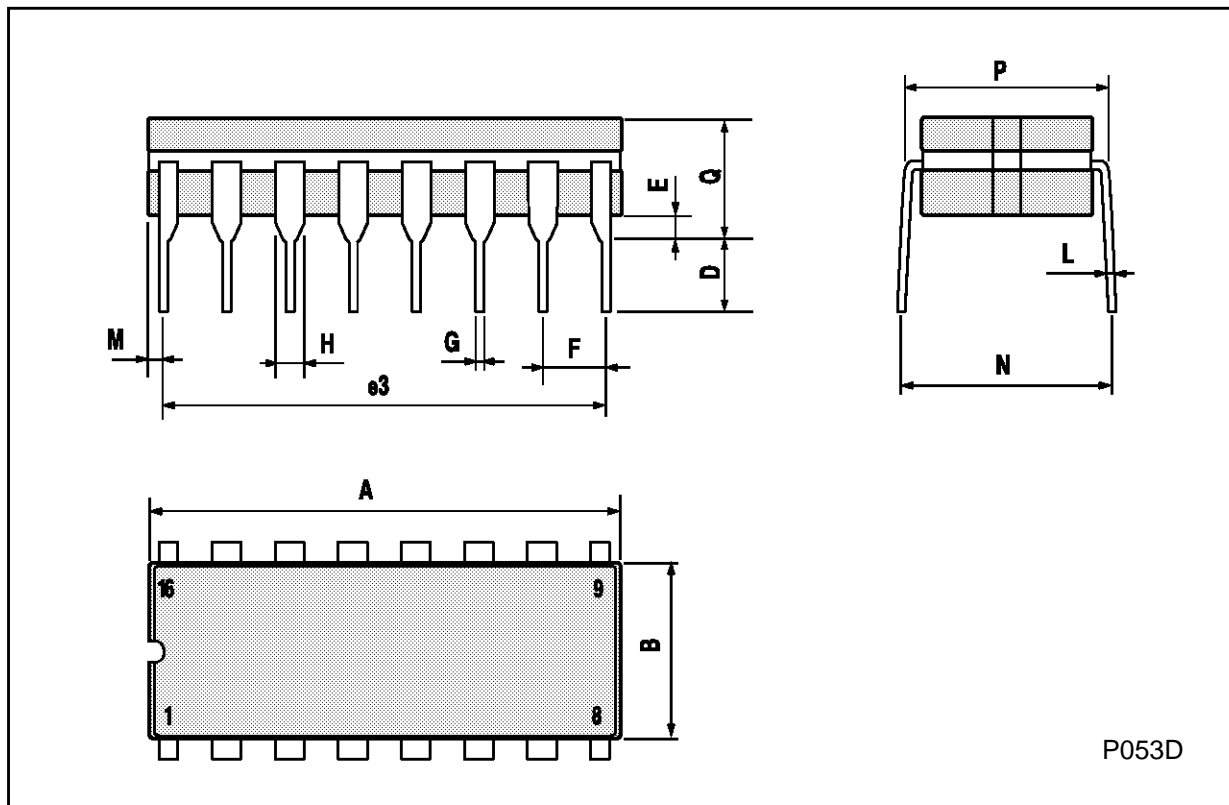

SO16 (Narrow) MECHANICAL DATA

DIM.	mm			inch		
	MIN.	TYP.	MAX.	MIN.	TYP.	MAX.
A			1.75			0.068
a1	0.1		0.2	0.004		0.007
a2			1.65			0.064
b	0.35		0.46	0.013		0.018
b1	0.19		0.25	0.007		0.010
C		0.5			0.019	
c1	45° (typ.)					
D	9.8		10	0.385		0.393
E	5.8		6.2	0.228		0.244
e		1.27			0.050	
e3		8.89			0.350	
F	3.8		4.0	0.149		0.157
G	4.6		5.3	0.181		0.208
L	0.5		1.27	0.019		0.050
M			0.62			0.024
S	8° (max.)					

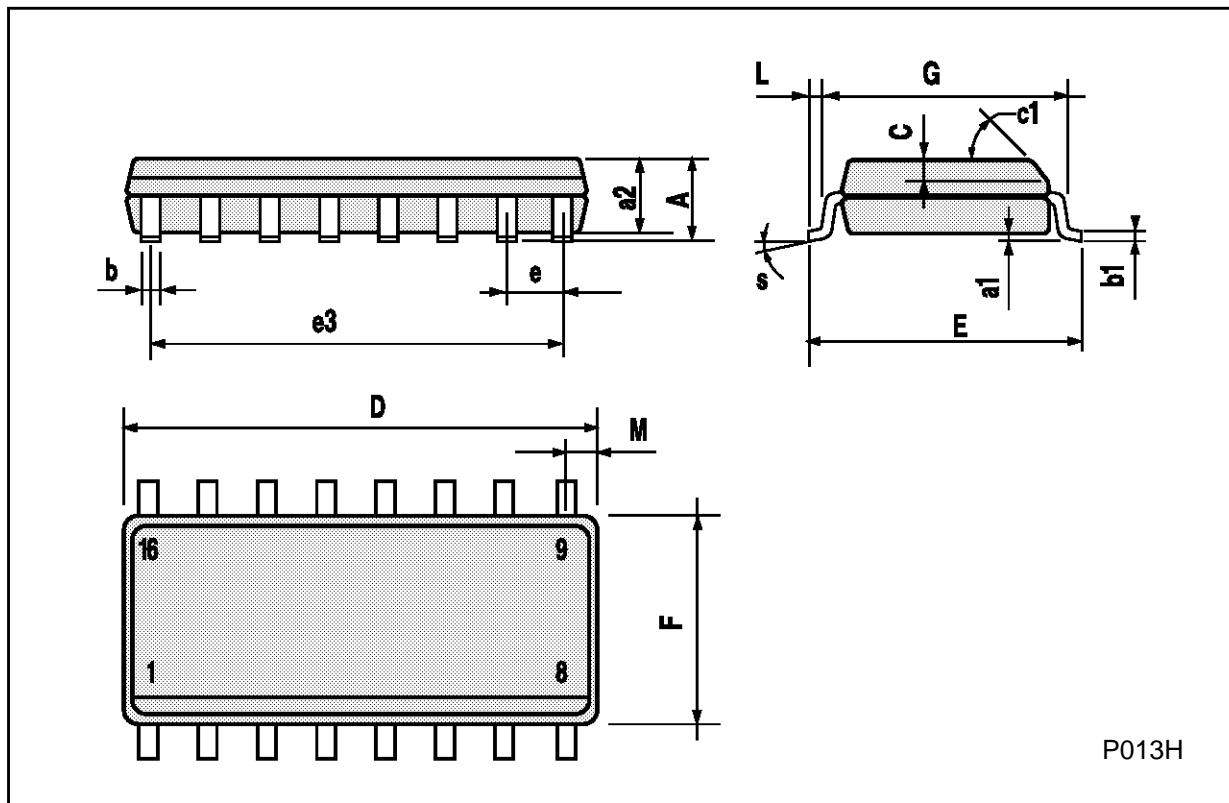

P013H

PLCC20 MECHANICAL DATA

DIM.	mm			inch		
	MIN.	TYP.	MAX.	MIN.	TYP.	MAX.
A	9.78		10.03	0.385		0.395
B	8.89		9.04	0.350		0.356
D	4.2		4.57	0.165		0.180
d1		2.54			0.100	
d2		0.56			0.022	
E	7.37		8.38	0.290		0.330
e		1.27			0.050	
e3		5.08			0.200	
F		0.38			0.015	
G			0.101			0.004
M		1.27			0.050	
M1		1.14			0.045	

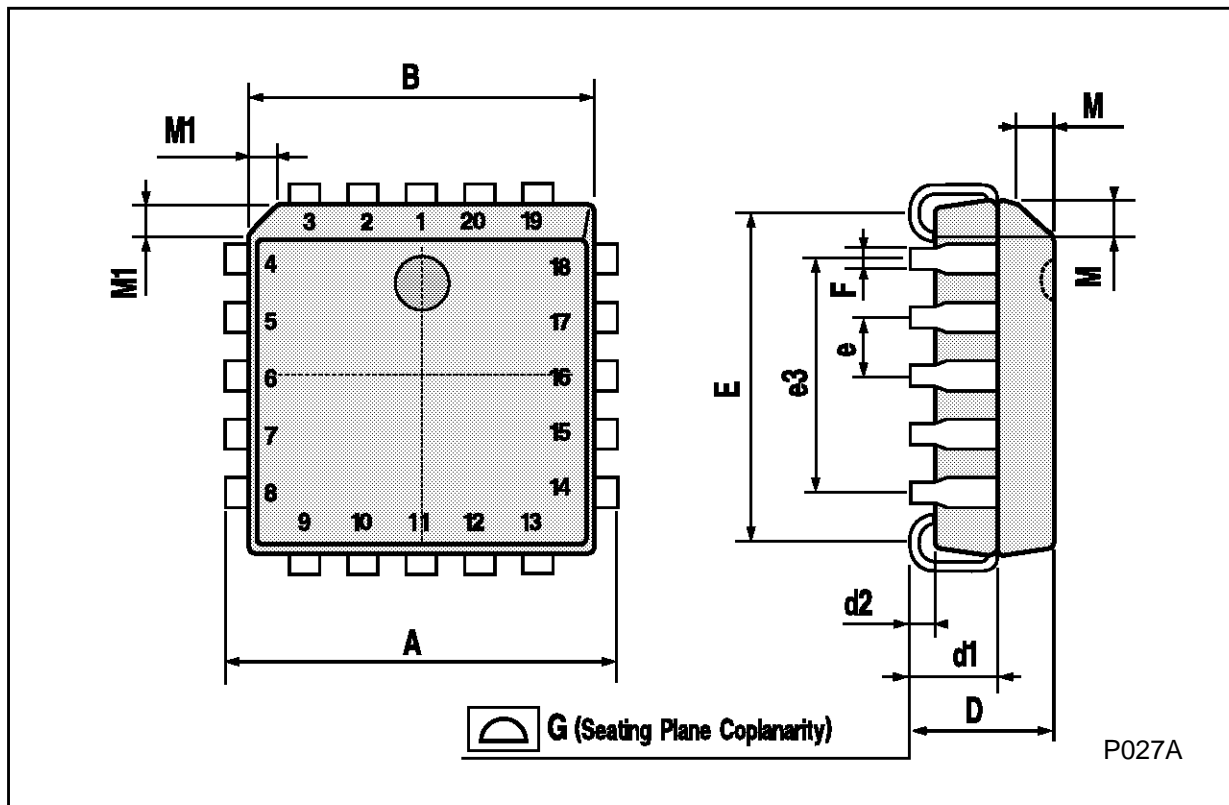

Information furnished is believed to be accurate and reliable. However, SGS-THOMSON Microelectronics assumes no responsibility for the consequences of use of such information nor for any infringement of patents or other rights of third parties which may result from its use. No license is granted by implication or otherwise under any patent or patent rights of SGS-THOMSON Microelectronics. Specifications mentioned in this publication are subject to change without notice. This publication supersedes and replaces all information previously supplied. SGS-THOMSON Microelectronics products are not authorized for use as critical components in life support devices or systems without express written approval of SGS-THOMSON Microelectronics.

© 1994 SGS-THOMSON Microelectronics - All Rights Reserved

SGS-THOMSON Microelectronics GROUP OF COMPANIES
Australia - Brazil - France - Germany - Hong Kong - Italy - Japan - Korea - Malaysia - Malta - Morocco - The Netherlands -
Singapore - Spain - Sweden - Switzerland - Taiwan - Thailand - United Kingdom - U.S.A