

January 1997

Monolithic PCM Repeater

Features

- Automatic Line Buildout
- Supply Voltage 5.1V
- Buffered Output

Applications

- Bipolar Carrier System T1 1.544Mbps/s
- Ternary Carrier System T148 2.37Mbps/s

Ordering Information

PART NUMBER	TEMP. RANGE (°C)	PACKAGE	PKG. NO.
CD22301E	-40 to 85	18 Ld PDIP	E18.3

Description

The CD22301 monolithic PCM repeater circuit is designed for T1 carrier systems operating with a bipolar pulse train of 1.544Mbps/s. It can also be used in the T148 carrier system operating with a ternary pulse train of 2.37Mbps/s. The circuit operates from a 5.1V ±5% externally regulated supply.

The CD22301 provides active circuitry to perform all functions of signal equalization and amplification, automatic line buildout (ALBO), threshold detection, clock extraction, pulse timing and buffered output formation.

Pinout

CD22301 (PDIP)
TOP VIEW

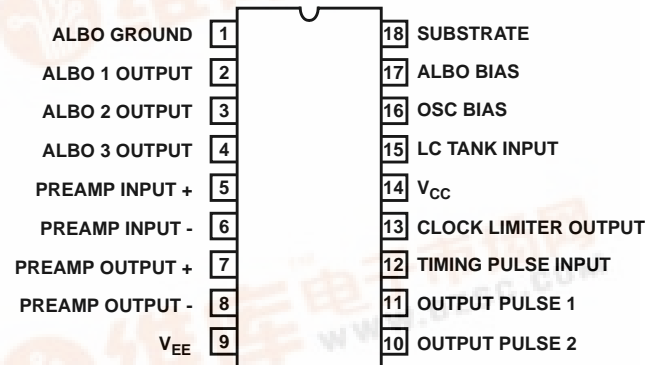

Functional Diagram

ALBO OUTPUT CIRCUIT

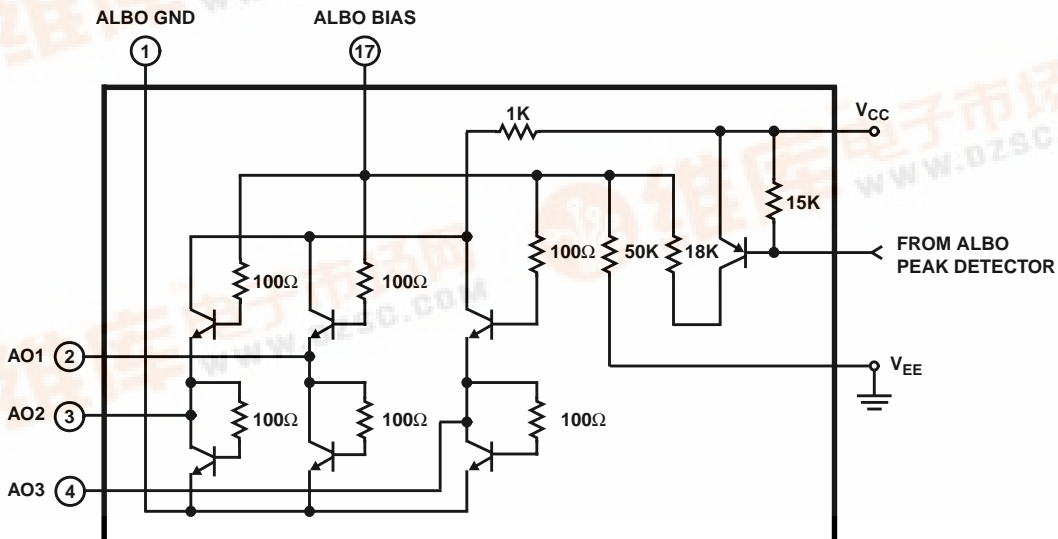

CD22301

Absolute Maximum Ratings

Supply Voltage	10V
Input Current (Into Pin 9 or 10)	25mA
Peak Current (Into Pin 9 or 10)	100mA
Input Surge Voltage (Between Pins 5 and 6, t = 10ms)	50V
Output Surge Voltage (Between Pins 10 and 11, t = 1ms)	50V
Power Dissipation	
For T _A = -40°C to 60°C	500mW
For T _A = 60°C to 85°C	Derate Linearly 12mW/°C to 200mW
Device Dissipation per Output Transistor	
For T _A = Full Package Temperature Range (All Types)	100mW

Thermal Information

Maximum Junction Temperature	175°C
Maximum Junction Temperature (Plastic Package)	150°C
Maximum Storage Temperature Range	-65°C ≤ T _A ≤ 150°C
Maximum Lead Temperature (Soldering 10s)	300°C

Operating Conditions

Temperature Range	-40°C ≤ T _A ≤ 85°C
-------------------	-------------------------------

CAUTION: Stresses above those listed in "Absolute Maximum Ratings" may cause permanent damage to the device. This is a stress only rating and operation of the device at these or any other conditions above those indicated in the operational sections of this specification is not implied.

Electrical Specifications T_A = 25°C, V_{CC} = 5.1V ±5% (See Figure 4)

PARAMETER	MIN	TYP	MAX	UNITS
STATIC DC VOLTAGES				
ALBO Pins (Pins 2, 3, 4 and 17)	-	0	0.1	V
Pre Amp Inputs and Outputs (Pins 5, 6, 7 and 8)	2.4	2.9	3.4	V
Output Pulse 1, 2 (Pins 10 and 11)	-	5.1	-	V
Oscillator/Clock (Pins 12, 13, 15 and 16)	3.1	3.6	4.1	V
STATIC DC CURRENTS				
I _{CC}	-	22	30	mA
Output Pulse 1, 2 (Pins 10 and 11)	-	0	100	μA

Electrical Specifications T_A = 25°C, V_{CC} = 5.1V ±5%

PARAMETER	SYMBOL	FIGURE	NOTE	MIN	TYP	MAX	UNITS
DYNAMIC SPECIFICATIONS							
Preamplifier Input Impedance	Z _{IN}	7		20	-	-	kΩ
Preamplifier Output Impedance	Z _{OUT}	7		-	-	2	kΩ
Preamplifier Gain at 2.37MHz	A _O	7		47	50	-	dB
Preamplifier Output Offset Voltage	ΔV _{OUT}	7	1	-50	0	50	mV
Clock Limiter Input Impedance	Z _{IN(CL)}	5	2	10	-	-	kΩ
ALBO Off Impedance	Z _{ALBO(off)}	5	3	20	-	-	kΩ
ALBO On Impedance	Z _{ALBO(on)}	5	4	-	-	10	Ω
DATA Threshold Voltage	V _{TH(D)}	6	5, 8	0.62	0.7	0.78	V
CLOCK Threshold Voltage	V _{TH(CL)}	6	6, 8	0.92	1.1	1.28	V
ALBO Threshold	V _{TH(AL)}	6	7, 8	1.4	1.5	1.6	V
V _{TH(D)} as % of V _{TH(AL)}				44	47	49	%
V _{TH(CL)} as % of V _{TH(AL)}				66	73	80	%
Buffer Gate Voltage (low)	V _{OL}	4	9	0.65	0.8	0.95	V
Differential Buffer Gate Voltage	ΔV _{OL}	4	9	-0.15	0	0.15	V
Output Pulse Rise Time	t _R	4, 8	9, 10	-	-	40	ns

CD22301

Electrical Specifications $T_A = 25^\circ\text{C}$, $V_{CC} = 5.1\text{V} \pm 5\%$ (Continued)

PARAMETER	SYMBOL	FIGURE	NOTE	MIN	TYP	MAX	UNITS
Output Pulse Fall Time	t_F	4, 8	9, 10	-	-	40	ns
Output Pulse Width	t_W	4, 8	9, 10	290	324	340	ns
Pulse Width Differential	Δt_W	4, 8	9, 10	-10	0	10	ns
Clock Drive Current	I_{CL}			-	2	-	mA

NOTES:

1. No signal input. Measure voltage between pins 7 and 8.
2. Measure clock limiter input impedance at pin 15. See Figure 5.
3. Adjust potentiometer for 0V (See Figure 5). Measure ALBO off impedances from pins 2, 3 and 4 to pin 1.
4. Increase potentiometer until voltage at pin 17 = 2V (See Figure 5). Measure ALBO on impedances from pins 2, 3 and 4 to pin 1.
5. Adjust potentiometer for $\Delta V = 0\text{V}$ (See Figure 6). Then slowly increase ΔV in the positive direction until pulses are observed at the DATA terminal.
6. Continue increasing ΔV until the DC level at the clock terminal drops to 4V (See Figure 6).
7. Continue increasing ΔV until the ALBO terminal rises to 1V (See Figure 6).
8. Turn potentiometer in the opposite direction and measure negative threshold voltages by repeating tests outlined in notes 5, 6 and 7.
9. Set $e_{IN} = 2.75\text{mV}_{\text{RMS}}$ at $f \approx 1.185\text{MHz}$. Adjust frequency until maximum amplitude is obtained at pin 15. Observe output pulses at pins 10 and 11.
10. Adjust input signal amplitude until pulses just appear in outputs. Increase input amplitude by 3dB.

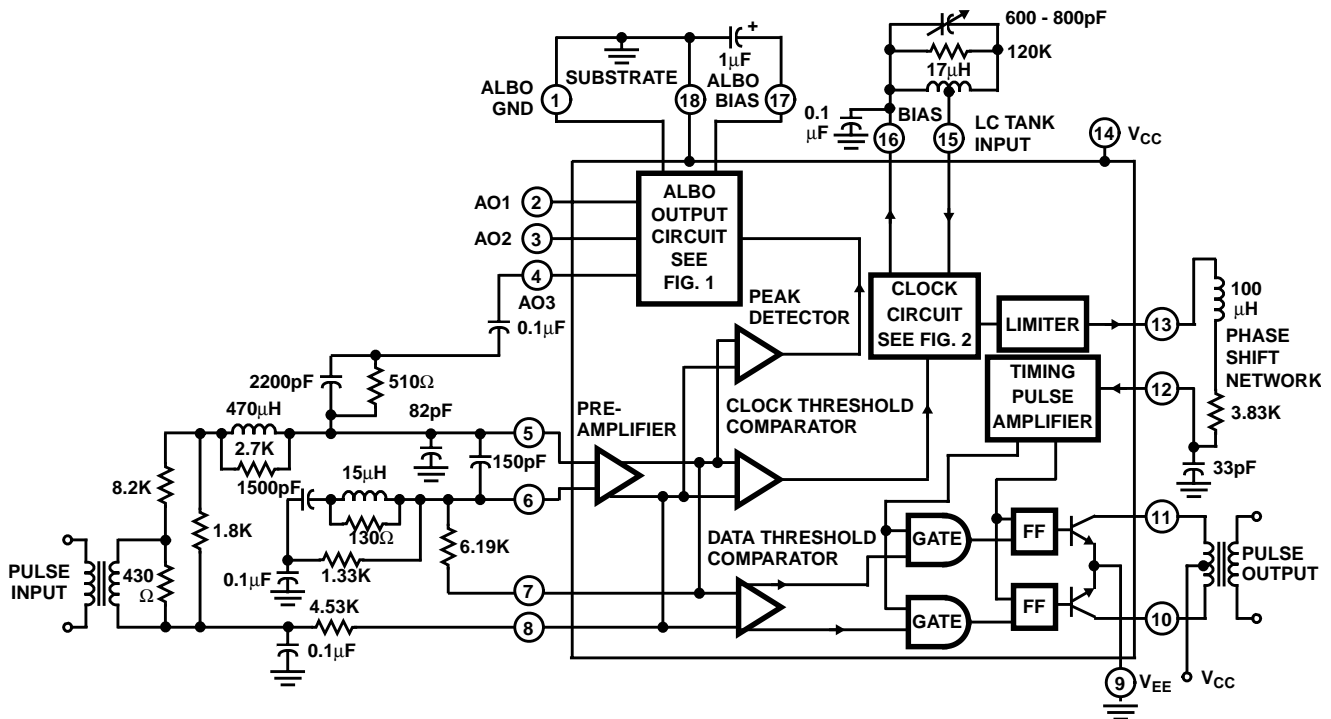

FIGURE 1. TYPICAL 1.544MHz T1 REPEATER SYSTEM

CD22301

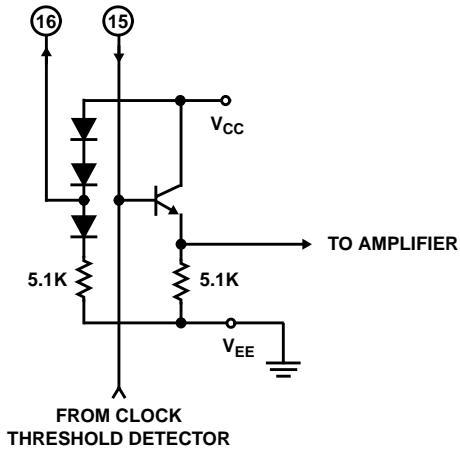

FIGURE 2. CLOCK INTERFACE CIRCUIT

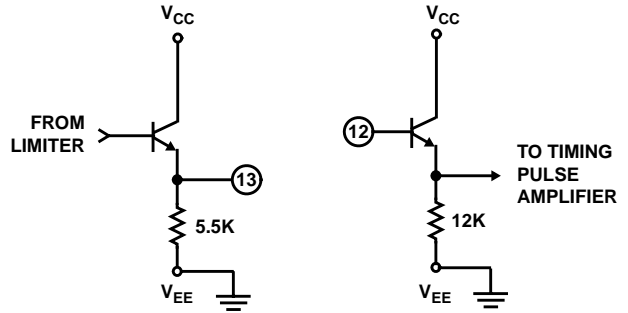

FIGURE 3. PHASE-SHIFT INTERFACE CIRCUITS

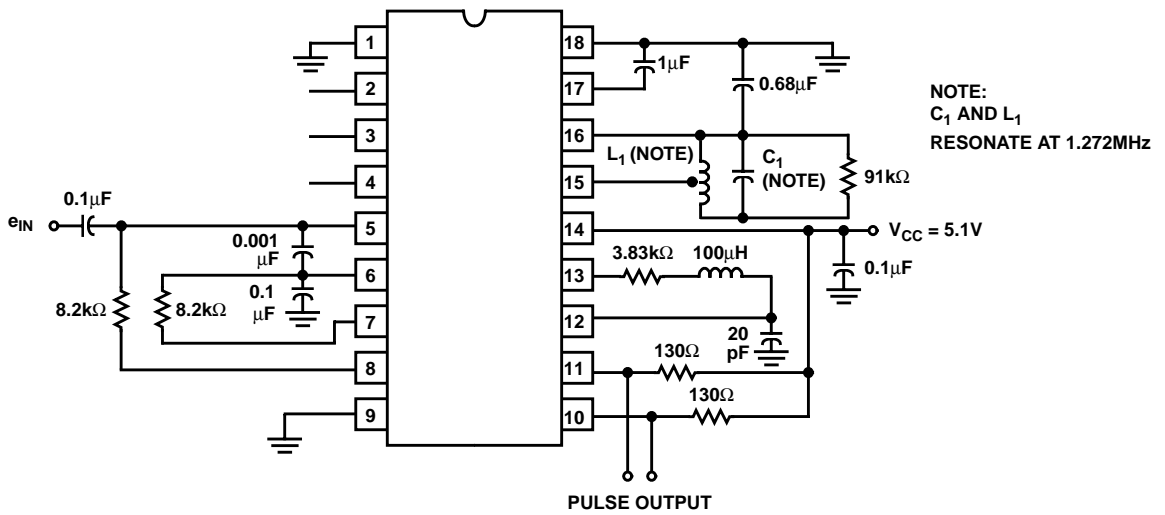

FIGURE 4. DC AND OUTPUT PULSE TEST CIRCUIT

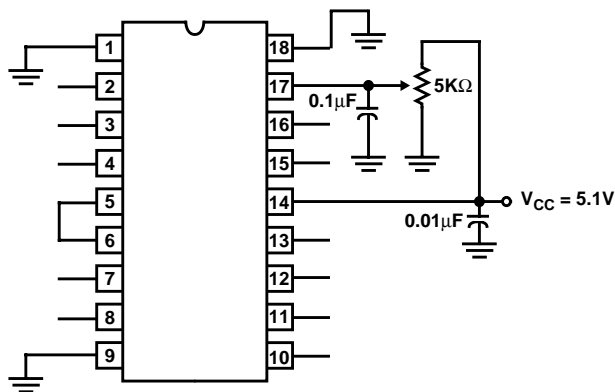

FIGURE 5. TEST CIRCUIT FOR IMPEDANCE MEASUREMENT

CD22301

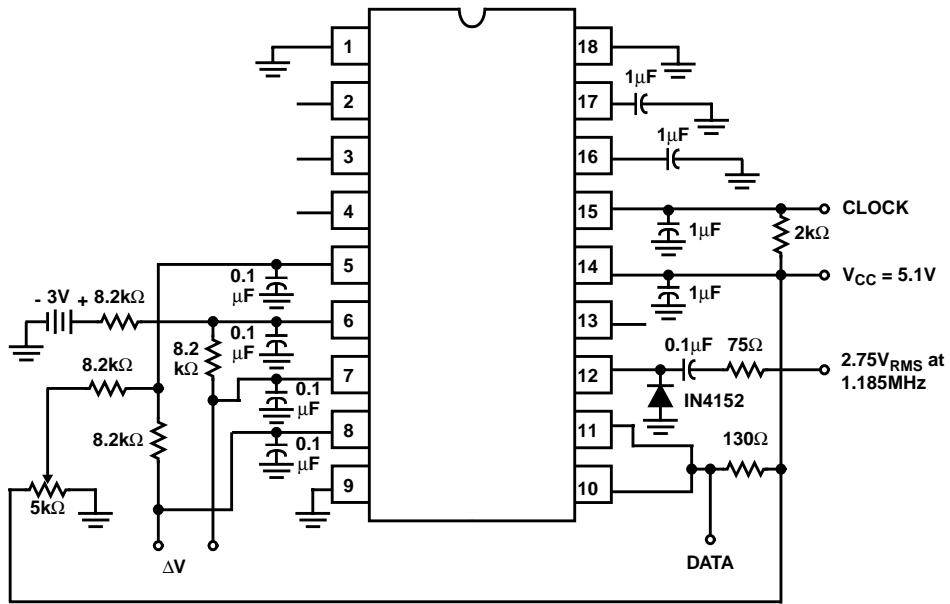

FIGURE 6. TEST CIRCUIT FOR THRESHOLD VOLTAGE MEASUREMENT

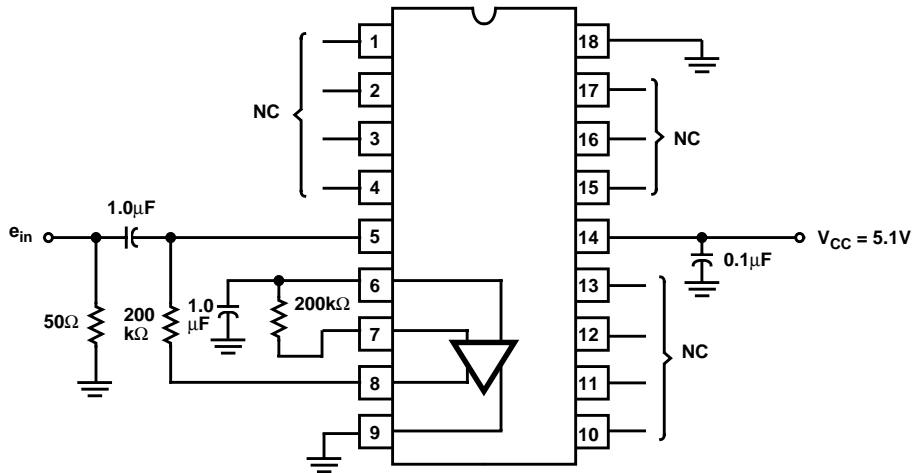

FIGURE 7. PREAMPLIFIER GAIN AND IMPEDANCE MEASUREMENT CIRCUIT

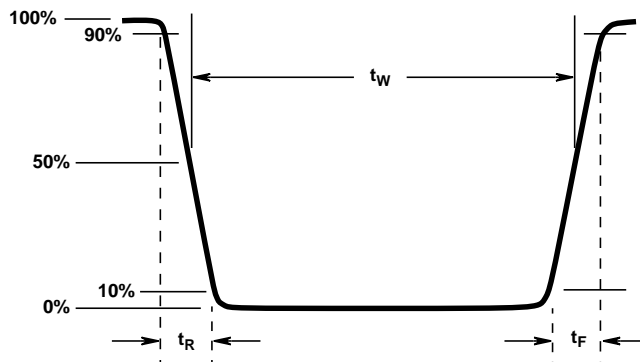

FIGURE 8. OUTPUT PULSE WAVEFORM

CD22301

All Intersil semiconductor products are manufactured, assembled and tested under **ISO9000** quality systems certification.

Intersil products are sold by description only. Intersil Corporation reserves the right to make changes in circuit design and/or specifications at any time without notice. Accordingly, the reader is cautioned to verify that data sheets are current before placing orders. Information furnished by Intersil is believed to be accurate and reliable. However, no responsibility is assumed by Intersil or its subsidiaries for its use; nor for any infringements of patents or other rights of third parties which may result from its use. No license is granted by implication or otherwise under any patent or patent rights of Intersil or its subsidiaries.

For information regarding Intersil Corporation and its products, see web site <http://www.intersil.com>

Sales Office Headquarters

NORTH AMERICA

Intersil Corporation
P. O. Box 883, Mail Stop 53-204
Melbourne, FL 32902
TEL: (407) 724-7000
FAX: (407) 724-7240

EUROPE

Intersil SA
Mercure Center
100, Rue de la Fusee
1130 Brussels, Belgium
TEL: (32) 2.724.2111
FAX: (32) 2.724.22.05

ASIA

Intersil (Taiwan) Ltd.
Taiwan Limited
7F-6, No. 101 Fu Hsing North Road
Taipei, Taiwan
Republic of China
TEL: (886) 2 2716 9310
FAX: (886) 2 2715 3029