

**OBSOLETE PRODUCT**  
**NO RECOMMENDED REPLACEMENT**  
 Call Central Applications 1-800-442-7747  
 or email: centapp@harris.com

## Monolithic Silicon COS/MOS Dual-Tone Multifrequency Tone Generator

The CD22859 is a CMOS dual-tone multifrequency (DTMF) tone generator for use in dual-tone telephone dialing systems. The device can easily be interfaced to a standard push-button telephone keyboard to provide enabling operation directly with the telephone lines.

The CD22859 generates standard DTMF sinusoidal dialing tones from an on-chip reference crystal oscillator. The reference oscillator uses an inexpensive 3.579545MHz color TV crystal to create highly stable and accurate tones. The sinusoidal tones are digitally synthesized by a stair-step approximation.

One of four low-frequency band row tones and one of four high-frequency band column tones are selected by driving one of the four row inputs and one of the four column inputs low. Simultaneous selection of more than one row input and/or more than one column input will inhibit tone generation, or generate a single-tone sinusoid. These operating modes are described in the functional truth table.

Control logic is included to allow easy interface to standard K500-type telephones. Two CMOS outputs ( $T_X$ ,  $R_X$ ) capable of driving external pnp receiver and transmitter muting transistors are provided. A low input to the  $\overline{CD}$  pin inhibits tone generation, turns off the reference oscillator and causes  $T_X$  and  $R_X$  outputs to go to logic '0'. During tone generation mode,  $\overline{CD} = 1$  and  $T_X, R_X = \text{logic } 1$ .

The row, column and  $\overline{CD}$  inputs are provided with pull-up resistors to allow the use of SPST switch matrixes.

## Ordering Information

PART NUMBER	TEMP. RANGE (°C)	PACKAGE	PKG. NO.
CD22859E	-40 to 85	16 Ld PDIP	E16.3

## Features

- Mute Drivers On-Chip
- Device Power can Either be Regulated DC or Telephone Loop Current
- Use of an Inexpensive 3.579545MHz TV Crystal Provides High Accuracy and Stability for all Frequencies

## Applications

- For Use In Dual-tone Telephone Dialing Systems

## Pinout

CD22859  
 (PDIP)  
 TOP VIEW

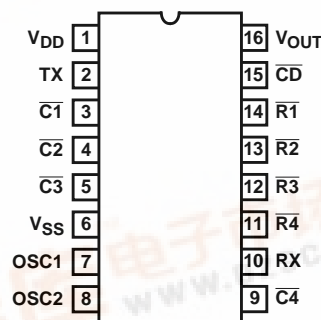

## CD22859

### Absolute Maximum Ratings

Supply Voltage ( $V_{DD} - V_{SS}$ )	-0.5 to 12V
Input Voltage	-0.5V to $V_{DD} 0.5V$
Power Dissipation, $P_D$	
$T_A = -40^{\circ}C$ to $60^{\circ}C$	.500mW
$T_A = 60^{\circ}C$ to $85^{\circ}C$	Derate Linearly at 1.2mW/ $^{\circ}C$ to 200mW

### Thermal Information

Maximum Junction Temperature	175 $^{\circ}C$
Maximum Junction Temperature (Plastic)	150 $^{\circ}C$
Maximum Storage Temperature Range	-65 $^{\circ}C$ to 150 $^{\circ}C$
Maximum Lead Temperature (Soldering 10s)	300 $^{\circ}C$

### Operating Conditions

Power Dissipation Per Output	.100mW
Temperature Range	-40 $^{\circ}C$ to 85 $^{\circ}C$

*CAUTION: Stresses above those listed in "Absolute Maximum Ratings" may cause permanent damage to the device. This is a stress only rating and operation of the device at these or any other conditions above those indicated in the operational sections of this specification is not implied.*

### Electrical Specifications $T_A = -25^{\circ}C$ to $60^{\circ}C$ , All Voltages Referenced to $V_{SS} = 0V$

PARAMETER	$V_{DD}$ (V)	MIN	MAX	UNITS
<b>DYNAMIC DC SUPPLY VOLTAGE</b>				
Tone Generation Mode with Valid Input (Note 1)		2.5	10	V
Non-Tone Generation (Note 2)		1.7	10	V
<b>DYNAMIC OPERATING CURRENT</b>				
Tone Generation Mode (Outputs Unloaded)	3.7	-	2.7	mA
	9.3	-	13	mA
No Keydown Mode	3.7	-	100	$\mu A$
	9.3	-	200	$\mu A$
Input Pull-Up Current	3 - 10	-	400	$\mu A$
Input Low Voltage ( $V_{IL}$ ) Maximum	3 - 10	-	$0.2V_{DD}$	V
Input Low Voltage ( $V_{IH}$ ) Minimum	3 - 10	-	$0.8V_{DD}$	V

### Electrical Specifications $T_A = -25^{\circ}C$ to $60^{\circ}C$

PARAMETER	$V_{DD}$ (V)	$V_O$ (V)	MIN	MAX	UNITS
<b>STATIC TONE OUTPUTS (<math>R_L = 82\Omega</math>)</b>					
$V_O$ ; Dual-Tone Output	3.7 - 9.3	-	350	700	mV <sub>RMS</sub>
$V_O$ ( $C_L$ ); Single-Tone Output, Column (Note 3)	3.7 - 9.3	-	300	-	mV <sub>RMS</sub>
$V_O$ ( $R_L$ ); Single-Tone Output, Row (Note 4)	3.7 - 9.3	-	260	-	mV <sub>RMS</sub>
Distortion (Note 5)	3.9 - 9.3	-	-	10	%
Rise and Fall Time (Dual-Tone Out) (Note 6)	3.9 - 9.3	-	-	5	ms
Pre-Emphasis (Note 7)	3.9 - 9.3	-	1	3	dB
Output Frequency (Note 8)	3.9 - 9.3	-	(Nom. -1%)	(Nom. +1%)	Hz

## CD22859

### Electrical Specifications $T_A = -25^{\circ}\text{C}$ to $60^{\circ}\text{C}$ (Continued)

PARAMETER	$V_{DD}$ (V)	$V_O$ (V)	MIN	MAX	UNITS
<b>STATIC MUTE OUTPUT CURRENT</b>					
Transmitter	1.7	1.2	-0.5	-	mA
$I_{OH}$ (Source)	10	9.5	-3.4	-	mA
$I_{OL}$ (Sink)	10	2.5	-	10	$\mu\text{A}$
Receiver	1.7	1.2	-0.5	-	mA
$I_{OH}$ (Source)	10	9.5	-3.4	-	mA
$I_{OL}$ (Sink)	10	2.5	-	10	$\mu\text{A}$

**NOTES:**

1. All logic and counters functional.
2. Mute switches remain open.
3. Two or more row inputs low and one column input low.
4. Two or more column inputs low and one row input low.
5. Distortion is defined as: The ratio of all extraneous frequency components generated in the voiceband 0.5kHz to 3kHz, to the power of the dual-tone signal, measure across  $R_L$ .

$$\text{Distortion} = \frac{\sqrt{(V_1^2 + V_2^2 + \dots + V_n^2)}}{\sqrt{V_L^2 + V_H^2}},$$

where  $V_1, V_2, \dots, V_n$  are extraneous frequency components in the voiceband 0.5kHz to 3kHz,  $V_L$  is the low-band frequency tone, and  $V_H$  is the high-band frequency tone.

6. Tone rise time is defined as the time for each of the 2 DTMF frequencies to attain 90% of full amplitude, measured from the time when a row and column signal are driven low.
7. Pre-emphasis is the ratio of the high-group level to the low-group level.
8. Refer to Figure 1 for standard DTMF frequencies.
9. Corresponds to normal dual-tone operation.
10. Corresponds to single-tone generation mode.

# CD22859

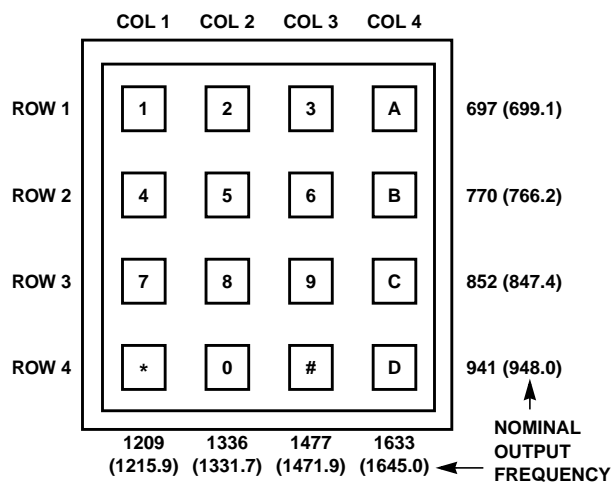

**FIGURE 1. BELL AND NOMINAL OUTPUT FREQUENCIES (IN PARENTHESIS) FOR 3.579545MHZ CRYSTAL**

### DTMF GENERATOR FUNCTIONAL TRUTH TABLE

KEYBOARD MODE	INPUTS			OUTPUTS			
	NUMBER OF COLUMN INPUTS ACTIVATED "LOW"	NUMBER OF ROW INPUTS ACTIVATED "LOW"	$\overline{CD}$	TONE	OSC RUNNING	R <sub>X</sub>	T <sub>X</sub>
X	X	X	"0"	None	No	"0"	"0"
No Key Depressed	0	0	"1"	None	No	"0"	"0"
	0	1	"1"	Dual Tone R <sub>A</sub> , C <sub>1</sub>	Yes	"1"	"1"
	1, 2, 3, or 4	0	"1"	None	No	"0"	"0"
Normal Dialing One Key Depressed (Note 9)	1	1	"1"	Dual Tone R <sub>A</sub> , C <sub>B</sub>	Yes	"1"	"1"
Two or More Keys In Same Row (Note 10)	2, 3, or 4	1	"1"	Single Row Tone R <sub>A</sub>	Yes	"1"	"1"
Two or More Keys In Same Column	1	2, 3, or 4	"1"	Single Column Tone C <sub>B</sub>	Yes	"1"	"1"
Two or More Keys In Different Rows and Columns	2, 3, or 4	2, 3, or 4	"1"	None	Yes	"1"	"1"

Where:

X = Don't Care

R<sub>A</sub> refers to Tone Output frequencies corresponding to Row 1, Row 2, Row 3, Row 4; C<sub>B</sub> refers to Tone Output frequencies corresponding to Column 1, Column 2, Column 3, Column 4.

A = 1, 2, 3, 4    B = 1, 2, 3, 4    A = B, or A ≠ B

Functional Diagram

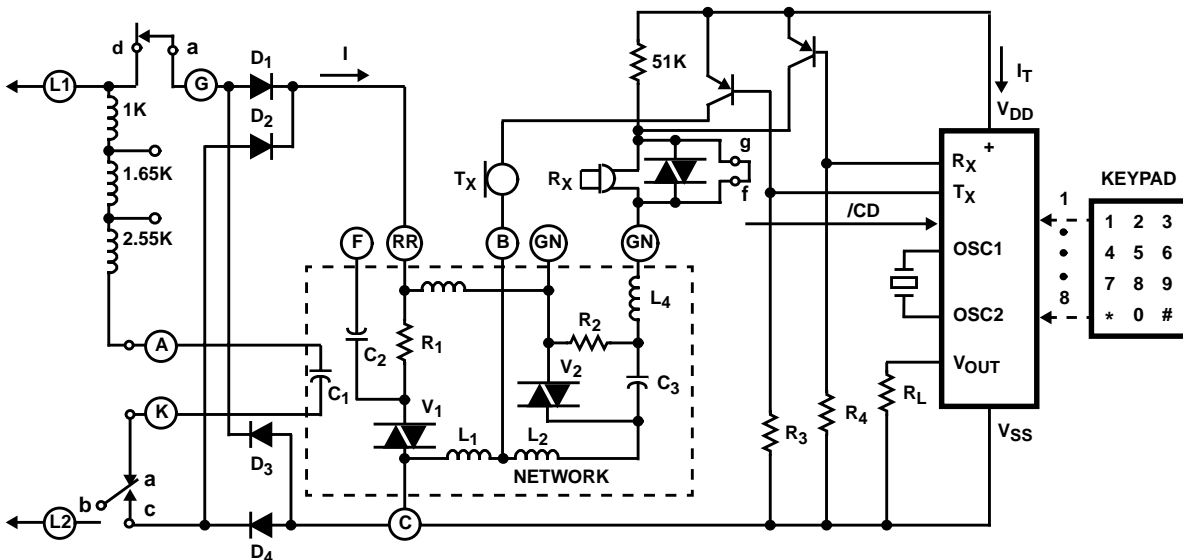
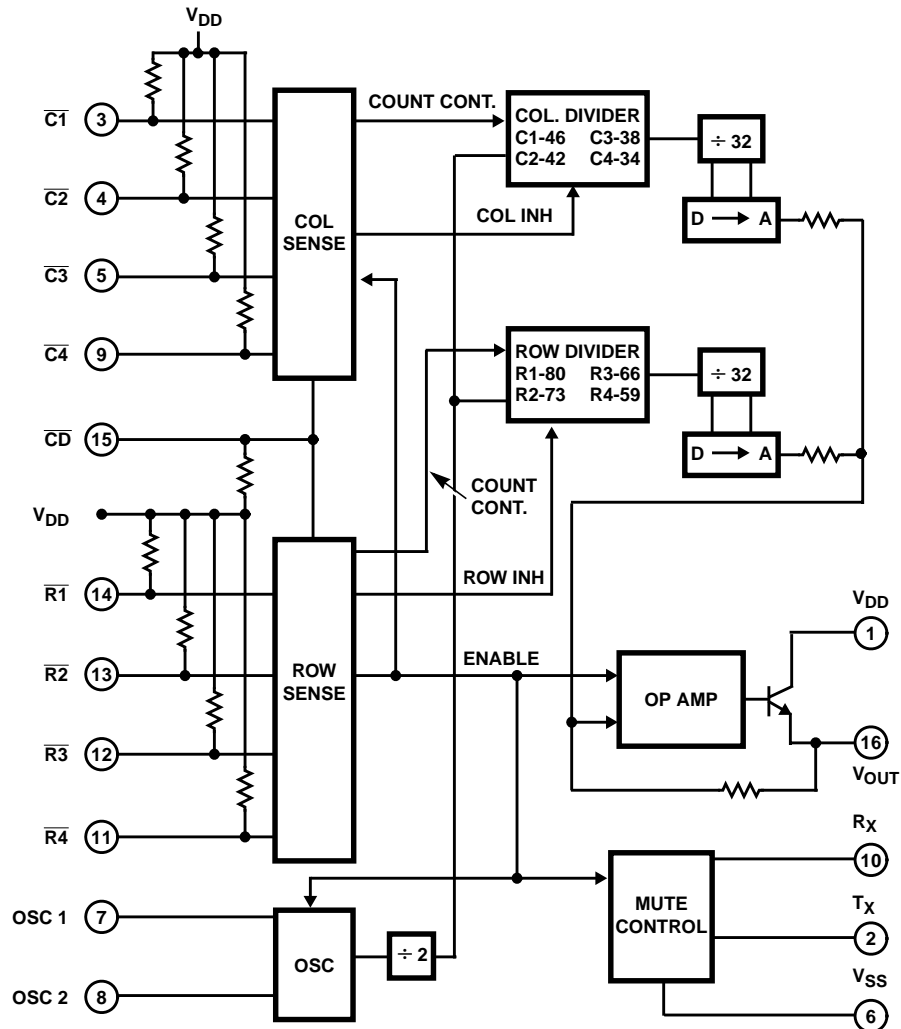

FIGURE 2. INTERFACE WITH STANDARD K500 TELEPHONE NETWORK