



CS43L42

Low Voltage, Stereo DAC with Headphone Amp

Features

- 1.8 to 3.3 Volt supply
- 24-Bit conversion / 96 kHz sample rate
- 96 dB dynamic range at 3 V supply
- -85 dB THD+N
- Low power consumption
- Digital volume control
 - 96 dB attenuation, 1 dB step size
- Digital bass and treble boost
 - Selectable corner frequencies
 - Up to 12 dB boost in 1 dB increments
- Peak signal limiting to prevent clipping
- De-emphasis for 32 kHz, 44.1 kHz, and 48 kHz
- Headphone amplifier
 - up to 25 mW_{rms} power output into 16 Ω load*
 - 25 dB analog attenuation and mute
 - Zero crossing click free level transitions
- ATAPI mixing functions
- 24-Pin TSSOP package

* 1 kHz sine wave at 3.3V supply

Description

The CS43L42 is a complete stereo digital-to-analog output system including interpolation, 1-bit D/A conversion, analog filtering, volume control, line level outputs, and a headphone amplifier, in a 24-pin TSSOP package.

The CS43L42 is based on delta-sigma modulation, where the modulator output controls the reference voltage input to an ultra-linear analog low-pass filter. This architecture allows infinite adjustment of the sample rate between 2 kHz and 100 kHz simply by changing the master clock frequency.

The CS43L42 contains on-chip digital bass and treble boost, peak signal limiting, and de-emphasis. The CS43L42 operates from a +1.8 V to +3.3 V supply and consumes only 16 mW of power with a 1.8 V supply with the line amplifier powered-down. These features are ideal for portable CD, MP3 and MD players and other portable playback systems that require extremely low power consumption.

ORDERING INFORMATION

CS43L42-KZ	-10 to 70 °C	24-pin TSSOP
CS43L42-KZZ, Lead Free	-10 to 70 °C	24-pin TSSOP
CDB43L42		Evaluation Board

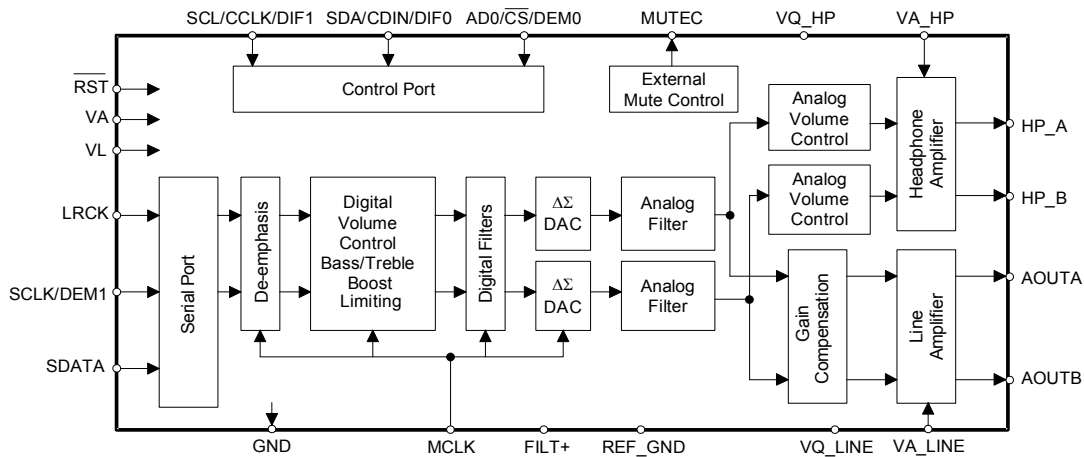

Preliminary Product Information

This document contains information for a new product. Cirrus Logic reserves the right to modify this product without notice.

TABLE OF CONTENTS

1. CHARACTERISTICS/SPECIFICATIONS	5
ANALOG CHARACTERISTICS	5
ANALOG CHARACTERISTICS	6
ANALOG CHARACTERISTICS	7
POWER AND THERMAL CHARACTERISTICS	8
DIGITAL CHARACTERISTICS	9
ABSOLUTE MAXIMUM RATINGS	9
RECOMMENDED OPERATING CONDITIONS	9
SWITCHING CHARACTERISTICS	10
SWITCHING CHARACTERISTICS - CONTROL PORT - TWO-WIRE MODE	12
SWITCHING CHARACTERISTICS - CONTROL PORT - SPI MODE	13
2. TYPICAL CONNECTION DIAGRAM	14
3. REGISTER QUICK REFERENCE	15
4. REGISTER DESCRIPTION	16
4.1 Power and Muting Control (address 01h)	16
4.1.1 Auto-mute (AMUTE)	16
4.1.2 Soft Ramp AND Zero Cross CONTROL (SZC)	16
4.1.3 Popguard® Transient Control (POR)	17
4.1.4 Power Down Headphone Amplifier (PDNHP)	17
4.1.5 Power Down Line Amplifier (PDNLN)	17
4.1.6 Power Down (PDN)	17
4.2 Channel A Analog Headphone Attenuation Control (address 02h) (HVOLA)	18
4.3 Channel B Analog Headphone Attenuation Control (address 03h) (hVOLB)	18
4.4 Channel A Digital Volume Control (address 04h) (DVOLA)	18
4.5 Channel B Digital Volume Control (address 05h) (DVOLB)	18
4.6 Tone Control (address 06h)	19
4.6.1 Bass Boost Level (BB)	19
4.6.2 Treble Boost Level (tb)	19
4.7 Mode Control (address 07h)	20
4.7.1 Bass Boost Corner Frequency (bbcf)	20
4.7.2 Treble Boost Corner Frequency (TBCF)	20
4.7.3 Channel A Volume = Channel B Volume (A=B)	20
4.7.4 De-Emphasis Control (DEM)	21
4.7.5 Digital Volume Control Bypass (VCBYP)	21
4.8 Limiter Attack Rate (address 08h) (ARATE)	21
4.9 Limiter Release Rate (address 09h) (RRATE)	22

Contacting Cirrus Logic Support

For a complete listing of Direct Sales, Distributor, and Sales Representative contacts, visit the Cirrus Logic web site at:
<http://www.cirrus.com/corporate/contacts/>

I²C is a registered trademark of Philips Semiconductors.

Preliminary product information describes products which are in production, but for which full characterization data is not yet available. Advance product information describes products which are in development and subject to development changes. Cirrus Logic, Inc. has made best efforts to ensure that the information contained in this document is accurate and reliable. However, the information is subject to change without notice and is provided "AS IS" without warranty of any kind (express or implied). No responsibility is assumed by Cirrus Logic, Inc. for the use of this information, nor for infringements of patents or other rights of third parties. This document is the property of Cirrus Logic, Inc. and implies no license under patents, copyrights, trademarks, or trade secrets. No part of this publication may be copied, reproduced, stored in a retrieval system, or transmitted, in any form or by any means (electronic, mechanical, photographic, or otherwise) without the prior written consent of Cirrus Logic, Inc. Items from any Cirrus Logic website or disk may be printed for use by the user. However, no part of the printout or electronic files may be copied, reproduced, stored in a retrieval system, or transmitted, in any form or by any means (electronic, mechanical, photographic, or otherwise) without the prior written consent of Cirrus Logic, Inc. Furthermore, no part of this publication may be used as a basis for manufacture or sale of any items without the prior written consent of Cirrus Logic, Inc. The names of products of Cirrus Logic, Inc. or other vendors and suppliers appearing in this document may be trademarks or service marks of their respective owners which may be registered in some jurisdictions. A list of Cirrus Logic, Inc. trademarks and service marks can be found at <http://www.cirrus.com>.

4.10 Volume and Mixing Control (address 0Ah).....	22
4.10.1 Tone Control MODE (TC).....	22
4.10.2 Tone Control Enable (TC_EN)	22
4.10.3 Peak Signal Limiter Enable (LIM_EN).....	23
4.10.4 ATAPI Channel Mixing and Muting (atapi)	23
4.11 Mode Control 2 (address 0Bh)	24
4.11.1 Master Clock DIVIDE ENABLE (mclkdiv).....	24
4.11.2 Line Amplifier Gain Compensation (line).....	24
4.11.3 Digital Interface Format (dif).....	24
5. PIN DESCRIPTION	26
6. APPLICATIONS	29
6.1 Grounding and Power Supply Decoupling	29
6.2 Clock Modes	29
6.3 De-Emphasis	29
6.4 Recommended Power-up Sequence	29
6.5 PopGuard® Transient Control	29
7. CONTROL PORT INTERFACE	30
7.1 SPI Mode	30
7.2 Two-Wire Mode	30
7.3 Memory Address Pointer (MAP)	31
7.3.1 INCR (Auto Map Increment Enable).....	31
7.3.2 MAP0-3 (Memory Address Pointer)	31
8. PARAMETER DEFINITIONS	39
9. REFERENCES	39
10. PACKAGE DIMENSIONS	40

LIST OF FIGURES

Figure 1. External Serial Mode Input Timing	11
Figure 2. Internal Serial Mode Input Timing	11
Figure 3. Internal Serial Clock Generation	11
Figure 4. Control Port Timing - Two-Wire Mode	12
Figure 5. Control Port Timing - SPI Mode	13
Figure 6. Typical Connection Diagram	14
Figure 7. Control Port Timing, SPI mode	31
Figure 8. Control Port Timing, Two-Wire Mode	31
Figure 9. Base-Rate Stopband Rejection	32
Figure 10. Base-Rate Transition Band	32
Figure 11. Base-Rate Transition Band (Detail)	32
Figure 12. Base-Rate Passband Ripple	32
Figure 13. High-Rate Stopband Rejection	32
Figure 14. High-Rate Transition Band	32
Figure 15. High-Rate Transition Band (Detail)	33
Figure 16. High-Rate Passband Ripple	33
Figure 17. Line Output Test Load	33
Figure 18. Headphone Output Test Load	33
Figure 19. CS43L42 Control Port Mode - Serial Audio Format 0	34
Figure 20. CS43L42 Control Port Mode - Serial Audio Format 1	34
Figure 21. CS43L42 Control Port Mode - Serial Audio Format 2	34
Figure 22. CS43L42 Control Port Mode - Serial Audio Format 3	35
Figure 23. CS43L42 Control Port Mode - Serial Audio Format 4	35
Figure 24. CS43L42 Control Port Mode - Serial Audio Format 5	35
Figure 25. CS43L42 Control Port Mode - Serial Audio Format 6	36
Figure 26. CS43L42 Stand Alone Mode - Serial Audio Format 0	36

Figure 27. CS43L42 Stand Alone Mode - Serial Audio Format 1	36
Figure 28. CS43L42 Stand Alone Mode - Serial Audio Format 2	37
Figure 29. CS43L42 Stand Alone Mode - Serial Audio Format 3	37
Figure 30. De-Emphasis Curve	38
Figure 31. ATAPI Block Diagram	38

LIST OF TABLES

Table 1. Example Analog Volume Settings	18
Table 2. Example Digital Volume Settings	19
Table 3. Example Bass Boost Settings	19
Table 4. Example Treble Boost Settings	19
Table 5. Example Limiter Attack Rate Settings	21
Table 6. Example Limiter Release Rate Settings	22
Table 7. ATAPI Decode	23
Table 8. Digital Interface Format	25
Table 9. Stand Alone De-Emphasis Control	27
Table 10. HRM Common Clock Frequencies	27
Table 11. BRM Common Clock Frequencies	27
Table 12. Digital Interface Format - DIF1 and DIF0 (Stand-Alone Mode)	28
Table 13.	

1. CHARACTERISTICS/SPECIFICATIONS

ANALOG CHARACTERISTICS

($T_A = 25^\circ\text{C}$; Logic "1" = $V_L = 1.8\text{ V}$; Logic "0" = $\text{GND} = 0\text{ V}$; Full-Scale Output Sine Wave, 997 Hz; MCLK = 12.288 MHz; Measurement Bandwidth 10 Hz to 20 kHz, unless otherwise specified; F_s for Base-rate Mode = 48 kHz, SCLK = 3.072 MHz. F_s for High-Rate Mode = 96 kHz, SCLK = 6.144 MHz. Test load $R_L = 10\text{ k}\Omega$, $C_L = 10\text{ pF}$ (see Figure 17) for line out, $R_L = 16\ \Omega$, $C_L = 10\text{ pF}$ (see Figure 18) for headphone out).

Parameter	Symbol	Base-rate Mode			High-Rate Mode			Unit
		Min	Typ	Max	Min	Typ	Max	
Line Output Dynamic Performance for $V_A = V_{A_LINE} = 1.8\text{ V}$								
Dynamic Range	(Note 1)							
18 to 24-Bit	unweighted	TBD	91	-	TBD	89	-	dB
	A-Weighted	TBD	94	-	TBD	92	-	dB
16-Bit	unweighted	-	89	-	-	87	-	dB
	A-Weighted	-	92	-	-	90	-	dB
Total Harmonic Distortion + Noise	(Note 1)	THD+N						
18 to 24-Bit	0 dB	-	-80	TBD	-	-80	TBD	dB
	-20 dB	-	-71	-	-	-69	-	dB
	-60 dB	-	-31	-	-	-29	-	dB
16-Bit	0 dB	-	-78	-	-	-78	-	dB
	-20 dB	-	-69	-	-	-67	-	dB
	-60 dB	-	-29	-	-	-27	-	dB
Interchannel Isolation	(1 kHz)	-	100	-	-	100	-	dB
Headphone Output Dynamic Performance for $V_A = V_{A_HP} = 1.8\text{ V}$								
Dynamic Range	(Note 1)							
18 to 24-Bit	unweighted	TBD	88	-	TBD	88	-	dB
	A-Weighted	TBD	91	-	TBD	91	-	dB
16-Bit	unweighted	-	86	-	-	86	-	dB
	A-Weighted	-	89	-	-	89	-	dB
Total Harmonic Distortion + Noise	(Note 1)	THD+N						
18 to 24-Bit	0 dB	-	-82	TBD	-	-85	TBD	dB
	-20 dB	-	-68	-	-	-68	-	dB
	-60 dB	-	-28	-	-	-28	-	dB
16-Bit	0 dB	-	-80	-	-	-83	-	dB
	-20 dB	-	-66	-	-	-66	-	dB
	-60 dB	-	-26	-	-	-26	-	dB
Interchannel Isolation	(1 kHz)	-	66	-	-	66	-	dB

Notes: 1. One-half LSB of triangular PDF dither is added to data.

ANALOG CHARACTERISTICS (Continued)

Parameter	Symbol	Base-rate Mode			High-Rate Mode			Unit			
		Min	Typ	Max	Min	Typ	Max				
Line Output Dynamic Performance for VA = VA_LINE = 3.0 V											
Dynamic Range.	(Note 1)		TBD	93	-	TBD	93	-	dB		
										18 to 24-Bit.	unweighted
											A-Weighted
										16-Bit.	unweighted
			-	91	-	-	91	-	dB		
			-	94	-	-	94	-	dB		
			-	94	-	-	94	-	dB		
Headphone Output Dynamic Performance for VA = VA_HP = 3.0 V											
Dynamic Range.	(Note 1)		TBD	90	-	TBD	90	-	dB		
										18 to 24-Bit.	unweighted
											A-Weighted
										16-Bit.	unweighted
			-	88	-	-	88	-	dB		
			-	91	-	-	91	-	dB		
Headphone Output Dynamic Performance for VA = VA_HP = 3.0 V											
Dynamic Range.	(Note 1)		TBD	90	-	TBD	90	-	dB		
										18 to 24-Bit.	unweighted
											A-Weighted
										16-Bit.	unweighted
			-	88	-	-	88	-	dB		
			-	91	-	-	91	-	dB		
Headphone Output Dynamic Performance for VA = VA_HP = 3.0 V											
Total Harmonic Distortion + Noise.	(Note 1)	THD+N	-	-85	TBD	-	-85	TBD	dB		
										18 to 24-Bit.	0 dB
											-20 dB
											-60 dB
			-	-73	-	-	-73	-	dB		
			-	-33	-	-	-33	-	dB		
16-Bit.	(Note 1)	THD+N	-	-83	-	-	-83	-	dB		
										0 dB	
										-20 dB	
										-60 dB	
			-	-71	-	-	-71	-	dB		
			-	-31	-	-	-31	-	dB		
Headphone Output Dynamic Performance for VA = VA_HP = 3.0 V											
Total Harmonic Distortion + Noise.	(Note 1)	THD+N	-	-76	TBD	-	-73	TBD	dB		
										18 to 24-Bit.	0 dB
											-20 dB
											-60 dB
			-	-70	-	-	-70	-	dB		
			-	-30	-	-	-30	-	dB		
16-Bit.	(Note 1)	THD+N	-	-74	-	-	-71	-	dB		
										0 dB	
										-20 dB	
										-60 dB	
			-	-68	-	-	-68	-	dB		
			-	-28	-	-	-28	-	dB		
Headphone Output Dynamic Performance for VA = VA_HP = 3.0 V											
Interchannel Isolation.	(1 kHz)		-	66	-	-	66	-	dB		

ANALOG CHARACTERISTICS (Continued)

Parameters	Symbol	Min	Typ	Max	Units
Analog Output					
Full Scale Line Output Voltage (Note 2)	V_{FS_LINE}	TBD	G x VA	TBD	Vpp
Line Output Quiescent Voltage	V_{Q_LINE}	-	0.5 x VA_LINE	-	VDC
Full Scale Headphone Output Voltage	V_{FS_HP}	TBD	0.55 x VA	TBD	Vpp
Headphone Output Quiescent Voltage	V_{Q_HP}	-	0.5 x VA_HP	-	VDC
Interchannel Gain Mismatch		-	0.1	-	dB
Gain Drift		-	100	-	ppm/°C
Maximum Line Output AC-Current VA=VA_LINE=1.8 V VA=VA_LINE=3.0 V	I_{LINE}	-	0.1 0.15	-	mA mA
Maximum Headphone Output AC-Current VA=VA_HP=1.8 V VA=VA_HP=3.0 V	I_{HP}	-	31 52	-	mA mA

Parameter	Symbol	Base-rate Mode			High-Rate Mode			Unit
		Min	Typ	Max	Min	Typ	Max	
Combined Digital and On-chip Analog Filter Response (Note 3)								
Passband (Note 4) to -0.05 dB corner to -0.1 dB corner to -3 dB corner		0 - 0	- - -	.4535 - .4998	- 0 0	- - -	- .4426 .4984	Fs Fs Fs
Frequency Response 10 Hz to 20 kHz (Note 5)		-0.02	-	+0.08	0	-	+0.11	dB
StopBand		.5465	-	-	.577	-	-	Fs
StopBand Attenuation (Note 6)		50	-	-	55	-	-	dB
Group Delay	tg _d	-	9/Fs	-	-	4/Fs	-	s
Passband Group Delay Deviation 0 - 40 kHz		-	-	-	-	±1.39/Fs	-	s
0 - 20 kHz		-	±0.36/Fs	-	-	±0.23/Fs	-	s
De-emphasis Error (Relative to 1 kHz)	Fs = 32 kHz Fs = 44.1 kHz Fs = 48 kHz	- - -	- - -	+0.2/-0.1 +0.05/-0.14 +0/-0.22	(Note 7)			dB dB dB

- Notes:
- See *Line Amplifier Gain Compensation (line)* for details.
 - Filter response is not tested but is guaranteed by design.
 - Response is clock dependent and will scale with Fs. Note that the response plots (Figures 9-16) have been normalized to Fs and can be de-normalized by multiplying the X-axis scale by Fs.
 - Referenced to a 1 kHz, full-scale sine wave.
 - For Base-Rate Mode, the measurement bandwidth is 0.5465 Fs to 3 Fs.
For High-Rate Mode, the measurement bandwidth is 0.577 Fs to 1.4 Fs.
 - De-emphasis is not available in High-Rate Mode.

POWER AND THERMAL CHARACTERISTICS (GND = 0 V; All voltages with respect to ground. All measurements taken with all zeros input and open outputs, unless otherwise specified.)

Parameters	Symbol	Min	Typ	Max	Units	
Power Supplies						
Power Supply Current- Normal Operation	VA=1.8 V	I_A	-	7.3	-	mA
	VA_HP=1.8 V	I_{A_HP}	-	1.5	-	mA
	VA_LINE=1.8 V	I_{A_LINE}	-	1.6	-	mA
	VL=1.8 V	I_{D_L}	-	4	-	μ A
Power Supply Current- Power Down Mode (Note 8)	VA=1.8 V	I_A	-	TBD	-	μ A
	VA_HP=1.8 V	I_{A_HP}	-	TBD	-	μ A
	VA_LINE=1.8 V	I_{A_LINE}	-	TBD	-	μ A
	VL=1.8 V	I_{D_L}	-	TBD	-	μ A
Power Supply Current- Normal Operation	VA=3.0 V	I_A	-	10.5	-	mA
	VA_HP=3.0 V	I_{A_HP}	-	1.5	-	mA
	VA_LINE=3.0 V	I_{A_LINE}	-	1.7	-	mA
	VL=3.0 V	I_{D_L}	-	9.3	-	μ A
Power Supply Current- Power Down Mode (Note 8)	VA=3.0 V	I_A	-	TBD	-	μ A
	VA_HP=3.0 V	I_{A_HP}	-	TBD	-	μ A
	VA_LINE=3.0 V	I_{A_LINE}	-	TBD	-	μ A
	VL=3.0 V	I_{D_L}	-	TBD	-	μ A
Total Power Dissipation- Normal Operation	All Supplies=1.8 V		-	19	TBD	mW
	All Supplies=3.0 V		-	41	TBD	mW
Maximum Headphone Power Dissipation (1 kHz full-scale sine wave into 16 ohm load)	VA=1.8 V		-	TBD	-	mW
	VA=3.0 V		-	TBD	-	mW
Package Thermal Resistance	θ_{JA}	-	75	-	$^{\circ}$ C/Watt	
Power Supply Rejection Ratio (Note 9)	(1 kHz)	PSRR	-	60	-	dB
	(60 Hz)		-	40	-	dB

- Notes: 8. Power Down Mode is defined as $\overline{RST} = LO$ with all clocks and data lines held static.
9. Valid with the recommended capacitor values on $FILT+$, VQ_LINE and VQ_HP as shown in Figure 6. Increasing the capacitance will also increase the PSRR. Note that care should be taken when selecting capacitor type, as any leakage current in excess of 1.0 μ A will cause degradation in analog performance.

DIGITAL CHARACTERISTICS ($T_A = 25^\circ\text{C}$; $V_L = 1.7\text{ V} - 3.6\text{ V}$; $\text{GND} = 0\text{ V}$)

Parameters	Symbol	Min	Typ	Max	Units
High-Level Input Voltage	V_{IH}	$0.7 \times V_L$	-	-	V
Low-Level Input Voltage	V_{IL}	-	-	$0.3 \times V_L$	V
Input Leakage Current	I_{in}	-	-	± 10	μA
Input Capacitance		-	8	-	pF
Maximum MUTE C Drive Capability	$V_A = 1.8\text{ V}$	-	TBD	-	mA
	$V_A = 3.0\text{ V}$	-	3	-	mA
MUTE C High-Level Output Voltage		-	V_A	-	V
MUTE C Low-Level Output Voltage		-	0	-	V

ABSOLUTE MAXIMUM RATINGS ($\text{GND} = 0\text{V}$; all voltages with respect to ground.)

Parameters	Symbol	Min	Max	Units	
DC Power Supplies:	Positive Analog	V_A	-0.3	4.0	V
	Headphone	V_{A_HP}	-0.3	4.0	V
	Line	V_{A_LINE}	-0.3	4.0	V
	Digital I/O	V_L	-0.3	4.0	V
Input Current, Any Pin Except Supplies	I_{in}	-	± 10	mA	
Digital Input Voltage	V_{IND}	-0.3	$V_L + 0.4$	V	
Ambient Operating Temperature (power applied)	T_A	-55	125	$^\circ\text{C}$	
Storage Temperature	T_{stg}	-65	150	$^\circ\text{C}$	

WARNING: Operation at or beyond these limits may result in permanent damage to the device. Normal operation is not guaranteed at these extremes.

RECOMMENDED OPERATING CONDITIONS ($\text{GND} = 0\text{V}$; all voltages with respect to ground.)

Parameters	Symbol	Min	Typ	Max	Units	
Ambient Temperature	T_A	-10	-	70	$^\circ\text{C}$	
DC Power Supplies:	Positive Analog	V_A	1.7	-	3.6	V
	Headphone	V_{A_HP}	0.9	-	3.6	V
	Line	V_{A_LINE}	V_A	-	3.6	V
	Digital I/O	V_L	1.7	-	3.6	V

Notes: 10. To prevent clipping the outputs, $V_{A_HP_MIN}$ is limited by the Full-Scale Output Voltage V_{FS_HP} , where V_{A_HP} must be 200 mV greater than V_{FS_HP} . However, if distortion is not a concern, V_{A_HP} may be as low as 0.9 V at any time.

SWITCHING CHARACTERISTICS ($T_A = -10$ to 70°C ; $V_L = 1.7\text{ V} - 3.6\text{ V}$; Inputs: Logic 0 = GND, Logic 1 = V_L , $C_L = 20\text{ pF}$)

Parameters		Symbol	Min	Typ	Max	Units
Input Sample Rate	Base Rate Mode	F_s	2	-	50	kHz
	High Rate Mode	F_s	50	-	100	kHz
MCLK Pulse Width High	MCLK/LRCK = 1024		7	-	-	ns
MCLK Pulse Width Low	MCLK/LRCK = 1024		7	-	-	ns
MCLK Pulse Width High	MCLK/LRCK = 768		10	-	-	ns
MCLK Pulse Width Low	MCLK/LRCK = 768		10	-	-	ns
MCLK Pulse Width High	MCLK/LRCK = 512		15	-	-	ns
MCLK Pulse Width Low	MCLK/LRCK = 512		15	-	-	ns
MCLK Pulse Width High	MCLK / LRCK = 384 or 192		25	-	-	ns
MCLK Pulse Width Low	MCLK / LRCK = 384 or 192		25	-	-	ns
MCLK Pulse Width High	MCLK / LRCK = 256 or 128		35	-	-	ns
MCLK Pulse Width Low	MCLK / LRCK = 256 or 128		35	-	-	ns
External SCLK Mode						
LRCK Duty Cycle (External SCLK only)			40	50	60	%
SCLK Pulse Width Low		t_{sckl}	20	-	-	ns
SCLK Pulse Width High		t_{sckh}	20	-	-	ns
SCLK Period	Base Rate Mode	t_{sckw}	$\frac{1}{(128)F_s}$	-	-	ns
	High Rate Mode	t_{sckw}	$\frac{1}{(64)F_s}$	-	-	ns
SCLK rising to LRCK edge delay		t_{slrd}	20	-	-	ns
SCLK rising to LRCK edge setup time		t_{slrs}	20	-	-	ns
SDATA valid to SCLK rising setup time		t_{sdhrs}	20	-	-	ns
SCLK rising to SDATA hold time		t_{sdh}	20	-	-	ns
Internal SCLK Mode (Note 11)						
LRCK Duty Cycle (Internal SCLK only) (Note 12)			-	50	-	%
SCLK Period		t_{sckw}	$\frac{1}{\text{SCLK}}$	-	-	ns
SCLK rising to LRCK edge		t_{sckr}	-	$\frac{t_{sckw}}{2}$	-	μs
SDATA valid to SCLK rising setup time		t_{sdhrs}	$\frac{1}{(512)F_s} + 10$	-	-	ns
SCLK rising to SDATA hold time	Base Rate Mode	t_{sdh}	$\frac{1}{(512)F_s} + 15$	-	-	ns
	High Rate Mode	t_{sdh}	$\frac{1}{(384)F_s} + 15$	-	-	ns

Notes: 11. Internal SCLK Mode timing is not tested, but is guaranteed by design.

12. In Internal SCLK Mode, the LRCK duty cycle must be 50% +/- 1/2 MCLK Period.

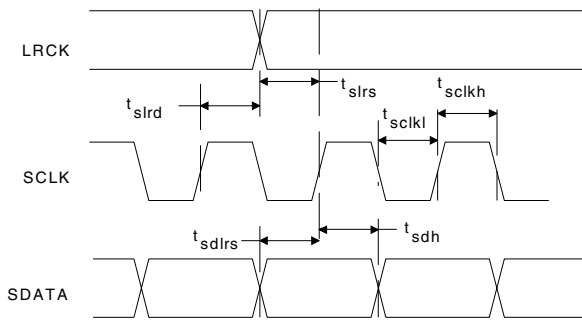

Figure 1. External Serial Mode Input Timing

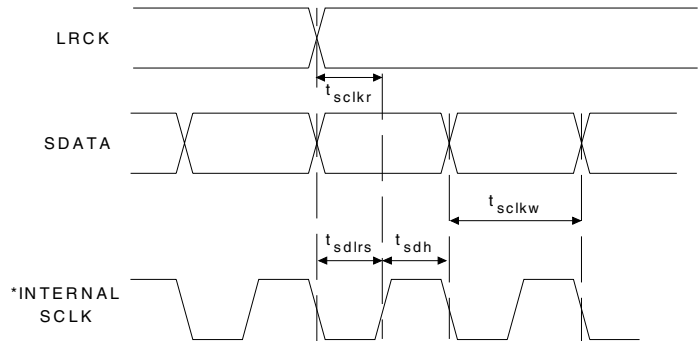

Figure 2. Internal Serial Mode Input Timing
 *The SCLK pulses shown are internal to the CS43L42.

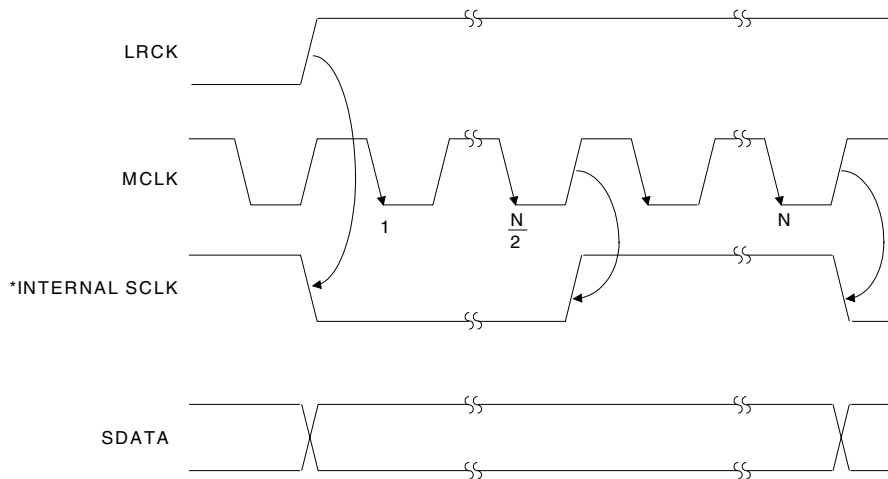

Figure 3. Internal Serial Clock Generation
 * The SCLK pulses shown are internal to the CS43L42.
 N equals MCLK divided by SCLK

SWITCHING CHARACTERISTICS - CONTROL PORT - TWO-WIRE MODE

($T_A = 25^\circ\text{C}$; $V_L = 1.7\text{ V} - 3.6\text{ V}$; Inputs: Logic 0 = GND, Logic 1 = V_L , $C_L = 30\text{ pF}$)

Parameter	Symbol	Min	Max	Unit
Two-Wire Mode (Note 13)				
SCL Clock Frequency	f_{scl}	-	100	kHz
RST Rising Edge to Start	t_{irs}	500	-	ns
Bus Free Time Between Transmissions	t_{buf}	4.7	-	μs
Start Condition Hold Time (prior to first clock pulse)	t_{hdst}	4.0	-	μs
Clock Low time	t_{low}	4.7	-	μs
Clock High Time	t_{high}	4.0	-	μs
Setup Time for Repeated Start Condition	t_{sust}	4.7	-	μs
SDA Hold Time from SCL Falling (Note 14)	t_{hdd}	0	-	μs
SDA Setup time to SCL Rising	t_{sud}	250	-	ns
Rise Time of SCL	t_{rc}	-	25	ns
Fall Time SCL	t_{fc}	-	25	ns
Rise Time of SDA	t_{rd}	-	1	μs
Fall Time of SDA	t_{fd}	-	300	ns
Setup Time for Stop Condition	t_{susp}	4.7	-	μs

Notes: 13. The Two-Wire Mode is compatible with the I²C protocol.

14. Data must be held for sufficient time to bridge the transition time, t_{fc} , of SCL.

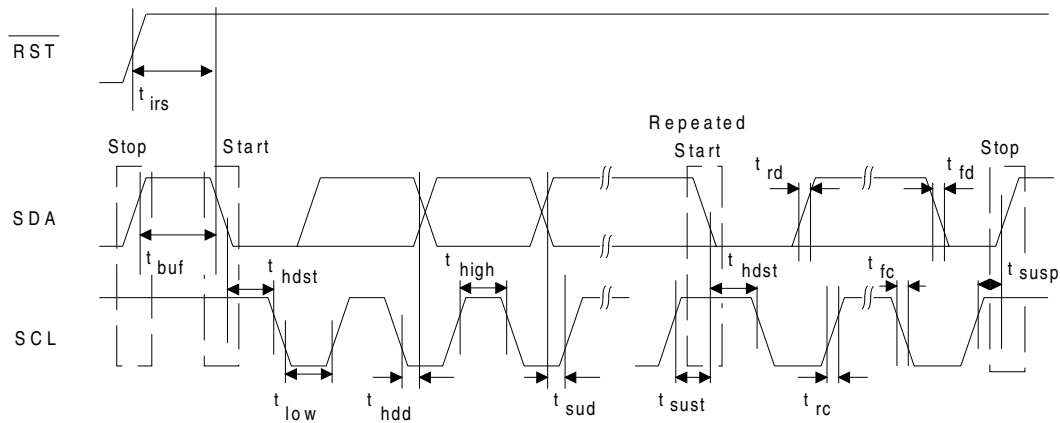

Figure 4. Control Port Timing - Two-Wire Mode

SWITCHING CHARACTERISTICS - CONTROL PORT - SPI MODE

($T_A = 25^\circ\text{C}$; $V_L = 1.7\text{ V} - 3.6\text{ V}$; Inputs: Logic 0 = GND, Logic 1 = V_L , $C_L = 30\text{ pF}$)

Parameter	Symbol	Min	Max	Unit
SPI Mode				
CCLK Clock Frequency	f_{sclk}	-	6	MHz
RST Rising Edge to CS Falling	t_{srs}	500	-	ns
CCLK Edge to CS Falling (Note 15)	t_{spi}	500	-	ns
CS High Time Between Transmissions	t_{csh}	1.0	-	μs
CS Falling to CCLK Edge	t_{css}	20	-	ns
CCLK Low Time	t_{scl}	66	-	ns
CCLK High Time	t_{sch}	66	-	ns
CDIN to CCLK Rising Setup Time	t_{dsu}	40	-	ns
CCLK Rising to DATA Hold Time (Note 16)	t_{dh}	15	-	ns
Rise Time of CCLK and CDIN (Note 17)	t_{r2}	-	100	ns
Fall Time of CCLK and CDIN (Note 17)	t_{f2}	-	100	ns

Notes: 15. t_{spi} only needed before first falling edge of $\overline{\text{CS}}$ after $\overline{\text{RST}}$ rising edge. $t_{\text{spi}} = 0$ at all other times.

16. Data must be held for sufficient time to bridge the transition time of CCLK.

17. For $F_{\text{SCK}} < 1\text{ MHz}$

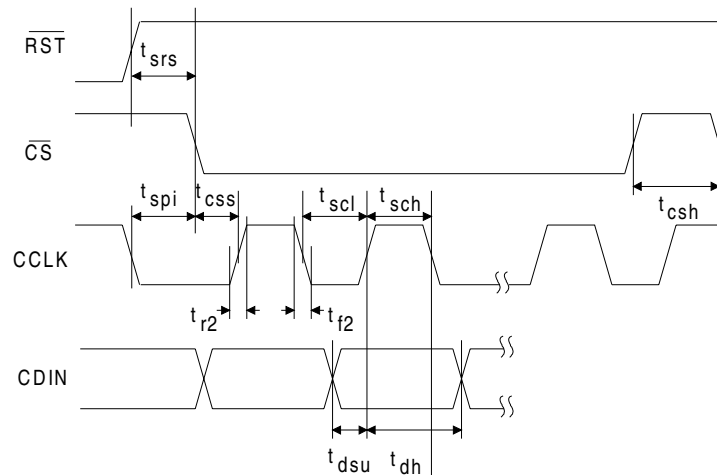

Figure 5. Control Port Timing - SPI Mode

2. TYPICAL CONNECTION DIAGRAM

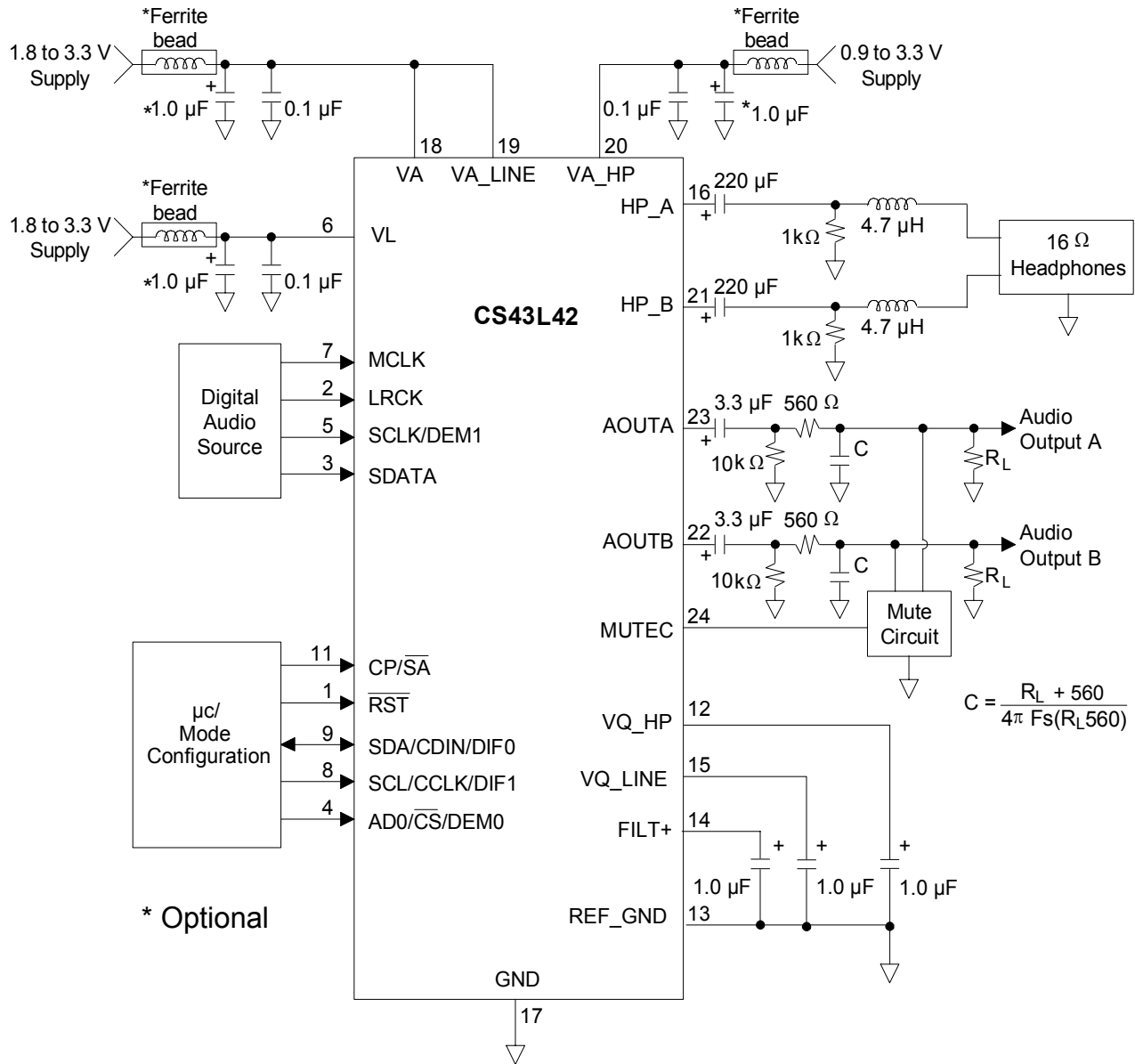

Figure 6. Typical Connection Diagram

3. REGISTER QUICK REFERENCE

Addr	Function	7	6	5	4	3	2	1	0
0h	Reserved default	Reserved 0	Reserved 0	Reserved 0	Reserved 0	Reserved 0	Reserved 0	Reserved 0	Reserved 0
1h	Power and Muting Control default	AMUTE 1	SZC1 1	SZC0 0	POR 1	PDNHP 0	PDNLN 0	PDN 1	Reserved 0
2h	Channel A Analog Headphone Attenuation Control default	HVOLA7 0	HVOLA6 0	HVOLA5 0	HVOLA4 0	HVOLA3 0	HVOLA2 0	HVOLA1 0	HVOLA0 0
3h	Channel B Analog Headphone Attenuation Control default	HVOLB7 0	HVOLB6 0	HVOLB5 0	HVOLB4 0	HVOLB3 0	HVOLB2 0	HVOLB1 0	HVOLB0 0
4h	Channel A Digital Volume Control default	DVOLA7 0	DVOLA6 0	DVOLA5 0	DVOLA4 0	DVOLA3 0	DVOLA2 0	DVOLA1 0	DVOLA0 0
5h	Channel B Digital Volume Control default	DVOLB7 0	DVOLB6 0	DVOLB5 0	DVOLB4 0	DVOLB3 0	DVOLB2 0	DVOLB1 0	DVOLB0 0
6h	Tone Control default	BB3 0	BB2 0	BB1 0	BB0 0	TB3 0	TB2 0	TB1 0	TB0 0
7h	Mode Control default	BBCF1 0	BBCF0 0	TBCF1 0	TBCF0 0	A=B 0	DEM1 0	DEM0 0	VCBYP 0
8h	Limiter Attack Rate default	ARATE7 0	ARATE6 0	ARATE5 0	ARATE4 1	ARATE3 0	ARATE2 0	ARATE1 0	ARATE0 0
9h	Limiter Release Rate default	RRATE7 0	RRATE6 0	RRATE5 1	RRATE4 0	RRATE3 0	RRATE2 0	RRATE1 0	RRATE0 0
Ah	Volume and Mixing Control default	TC1 0	TC0 0	TC_EN 0	LIM_EN 0	ATAPI3 1	ATAPI2 0	ATAPI1 0	ATAPI0 1
Bh	Mode Control 2 default	MCLKDIV 0	LINE1 0	LINE0 0	Reserved 0	Reserved 0	DIF2 0	DIF1 0	DIF0 0

4. REGISTER DESCRIPTION

Note: All registers are read/write in Two-Wire mode and write only in SPI, unless otherwise noted.

4.1 Power and Muting Control (address 01h)

7	6	5	4	3	2	1	0
AMUTE	SZC1	SZC0	POR	PDNHP	PDNLN	PDN	RESERVED
1	1	0	1	0	0	1	0

4.1.1 AUTO-MUTE (AMUTE)

Default = 1

0 - Disabled

1 - Enabled

Function:

The Digital-to-Analog converter output will mute following the reception of 8192 consecutive audio samples of static 0 or -1. A single sample of non-static data will release the mute. Detection and muting is done independently for each channel. The quiescent voltage on the output will be retained and the Mute Control pin will go active during the mute period. The muting function is affected, similar to volume control changes, by the Soft and Zero Cross bits in the Power and Muting Control register.

4.1.2 SOFT RAMP AND ZERO CROSS CONTROL (SZC)

Default = 10

00 - Immediate Change

01 - Zero Cross Digital and Analog

10 - Ramped Digital and Analog

11 - Reserved

Function:

Immediate Change

When Immediate Change is selected all level changes will take effect immediately in one step.

Zero Cross Digital and Analog

Zero Cross Enable dictates that signal level changes, either by attenuation changes or muting, will occur on a signal zero crossing to minimize audible artifacts. The requested level change will occur after a timeout period of 512 sample periods (10.7 ms at 48 kHz sample rate) if the signal does not encounter a zero crossing. The zero cross function is independently monitored and implemented for each channel.

Ramped Digital and Analog

Soft Ramp allows digital level changes, both muting and attenuation, to be implemented by incrementally ramping, in 1/8 dB steps, from the current level to the new level at a rate of 1 dB per 8 left/right clock periods. Analog level changes will occur in 1 dB steps on a signal zero crossing. The analog level change will occur after a timeout period of 512 sample periods (10.7 ms at 48 kHz sample rate) if the signal does not encounter a zero crossing. The zero cross function is independently monitored and implemented for each channel.

Note: Ramped Digital and Analog is not available in High-Rate Mode.

4.1.3 POPGUARD[®] TRANSIENT CONTROL (POR)

Default - 1
0 - Disabled
1 - Enabled

Function:

The PopGuard[®] Transient Control allows the quiescent voltage to slowly ramp to and from 0 volts to the quiescent voltage during power-on or power-off when this function is enabled. Please see section 6.5 for implementation details.

4.1.4 POWER DOWN HEADPHONE AMPLIFIER (PDNHP)

Default = 0
0 - Disabled
1 - Enabled

Function:

The headphone amplifier will independently enter a low-power state when this function is enabled.

4.1.5 POWER DOWN LINE AMPLIFIER (PDNLN)

Default = 0
0 - Disabled
1 - Enabled

Function:

The line output amplifier will independently enter a low-power state when this function is enabled.

4.1.6 POWER DOWN (PDN)

Default = 1
0 - Disabled
1 - Enabled

Function:

The entire device will enter a low-power state when this function is enabled, and the contents of the control registers are retained in this mode. The power-down bit defaults to 'enabled' on power-up and must be disabled before normal operation will begin.

4.2 Channel A Analog Headphone Attenuation Control (address 02h) (HVOLA)

4.3 Channel B Analog Headphone Attenuation Control (address 03h) (hVOLB)

7	6	5	4	3	2	1	0
HVOLx7	HVOLx6	HVOLx5	HVOLx4	HVOLx3	HVOLx2	HVOLx1	HVOLx0
0	0	0	0	0	0	0	0

Default = 0 dB (No attenuation)

Function:

The Analog Headphone Attenuation Control operates independently from the Digital Volume Control. The Analog Headphone Attenuation Control registers allow attenuation of the headphone output signal for each channel in 1 dB increments from 0 to -25 dB. Attenuation settings are decoded using a 2's complement code, as shown in Table 1. The volume changes are implemented as dictated by the Soft and Zero Cross bits in the Power and Muting Control register. All volume settings greater than zero are interpreted as zero.

Note: The Analog Headphone Attenuation only affects the headphone outputs.

Binary Code	Decimal Value	Volume Setting
00000000	0	0 dB
11110110	-10	-10 dB
11110001	-15	-15 dB

Table 1. Example Analog Volume Settings

4.4 Channel A Digital Volume Control (address 04h) (DVOLA)

4.5 Channel B Digital Volume Control (address 05h) (DVOLB)

7	6	5	4	3	2	1	0
DVOLx7	DVOLx6	DVOLx5	DVOLx4	DVOLx3	DVOLx2	DVOLx1	DVOLx0
0	0	0	0	0	0	0	0

Default = 0 dB (No attenuation)

Function:

The Digital Volume Control registers allow independent control of the signal levels in 1 dB increments from +18 to -96 dB. Volume settings are decoded using a 2's complement code, as shown in Table 2. The volume changes are implemented as dictated by the Soft and Zero Cross bits in the Power and Muting Control register. All volume settings less than -96 dB are equivalent to muting the channel via the ATAPI bits (see Section 4.10.4).

Note: The digital volume control affects both the line outputs and the headphone outputs. Setting this register to values greater than +18 dB will cause distortion in the audio outputs.

Binary Code	Decimal Value	Volume Setting
00001010	12	+12 dB
00000111	7	+7 dB
00000000	0	0 dB
11000100	-60	-60 dB
10100110	-90	-90 dB

Table 2. Example Digital Volume Settings

4.6 Tone Control (address 06h)

7	6	5	4	3	2	1	0
BB3	BB2	BB1	BB0	TB3	TB2	TB1	TB0
0	0	0	0	0	0	0	0

4.6.1 BASS BOOST LEVEL (BB)

Default = 0 dB (No Bass Boost)

Function:

The level of the shelving bass boost filter is set by Bass Boost Level. The level can be adjusted in 1 dB increments from 0 to +12 dB of boost. Boost levels are decoded as shown in Table 3. Levels above +12 dB are interpreted as +12 dB.

Binary Code	Decimal Value	Boost Setting
0000	0	0 dB
0010	2	+2 dB
1010	6	+6 dB
1001	9	+9 dB
1100	12	+12 dB

Table 3. Example Bass Boost Settings

4.6.2 TREBLE BOOST LEVEL (TB)

Default = 0 dB (No Treble Boost)

Function:

The level of the shelving treble boost filter is set by Treble Boost Level. The level can be adjusted in 1 dB increments from 0 to +12 dB of boost. Boost levels are decoded as shown in Table 4. Levels above +12 dB are interpreted as +12 dB.

Note: Treble Boost is not available in High-Rate Mode.

Binary Code	Decimal Value	Boost Setting
0000	0	0 dB
0010	2	+2 dB
1010	6	+6 dB
1001	9	+9 dB
1100	12	+12 dB

Table 4. Example Treble Boost Settings

4.7 Mode Control (address 07h)

7	6	5	4	3	2	1	0
BBCF1	BBCF0	TBCF1	TBCF0	A=B	DEM1	DEM0	VCBYP
0	0	0	0	0	0	0	0

4.7.1 BASS BOOST CORNER FREQUENCY (BBCF)

Default = 00

- 00 - 50 Hz
- 01 - 100 Hz
- 10 - 200 Hz
- 11 - Reserved

Function:

The bass boost corner frequency is user selectable as shown above.

4.7.2 TREBLE BOOST CORNER FREQUENCY (TBCF)

Default = 00

- 00 - 2 kHz
- 01 - 4 kHz
- 10 - 7 kHz
- 11 - Reserved

Function:

The treble boost corner frequency is user selectable as shown above.

Note: Treble Boost is not available in High-Rate Mode.

4.7.3 CHANNEL A VOLUME = CHANNEL B VOLUME (A=B)

Default = 0

- 0 - Disabled
- 1 - Enabled

Function:

The AOUTA/HP_A and AOUTB/HP_B volume levels are independently controlled by the A and the B Channel Volume Control Bytes when this function is disabled. The volume on both AOUTA/HP_A and AOUTB/HP_B are determined by the A Channel Attenuation and Volume Control Bytes, and the B Channel Bytes are ignored when this function is enabled.

4.7.4 DE-EMPHASIS CONTROL (DEM)

Default = 00
 00 - Disabled
 01 - 44.1 kHz
 10 - 48 kHz
 11 - 32 kHz

Function:

Selects the appropriate digital filter to maintain the standard 15 μ s/50 μ s digital de-emphasis filter response at 32, 44.1 or 48 kHz sample rates. (see Figure 30)

Note: De-emphasis is not available in High-Rate Mode.

4.7.5 DIGITAL VOLUME CONTROL BYPASS (VCBYP)

Default = 0
 0 - Disabled
 1 - Enabled

Function:

The digital volume control section is bypassed when this function is enabled. This disables the digital volume control, muting, bass boost, treble boost, limiting and ATAPI functions. The analog headphone attenuation control will remain functional.

4.8 Limiter Attack Rate (address 08h) (ARATE)

7	6	5	4	3	2	1	0
ARATE7	ARATE6	ARATE5	ARATE4	ARATE3	ARATE2	ARATE1	ARATE0
0	0	0	1	0	0	0	0

Default = 10h - 2 LRCK's per 1/8 dB

Function:

The limiter attack rate is user selectable. The rate is a function of sampling frequency, F_s , and the value in the Limiter Attack Rate register. Rates are calculated using the function $RATE = 32/\{value\}$, where $\{value\}$ is the decimal value in the Limiter Attack Rate register and RATE is in LRCK's per 1/8 dB of change.

Note: A value of zero in this register is not recommended, as it will induce erratic behavior of the limiter. Use the LIM_EN bit to disable the limiter function (see *Peak Signal Limiter Enable (LIM_EN)*).

Binary Code	Decimal Value	LRCK's per 1/8 dB
00000001	1	32
00010100	20	1.6
00101000	40	0.8
00111100	60	0.53
01011010	90	0.356

Table 5. Example Limiter Attack Rate Settings

4.9 Limiter Release Rate (address 09h) (RRATE)

7	6	5	4	3	2	1	0
RRATE7	RRATE6	RRATE5	RRATE4	RRATE3	RRATE2	RRATE1	RRATE0
0	0	1	0	0	0	0	0

Default = 20h - 16 LRCK's per 1/8 dB

Function:

The limiter release rate is user selectable. The rate is a function of sampling frequency, F_s , and the value in the Limiter Release Rate register. Rates are calculated using the function $RATE = 512/\{value\}$, where $\{value\}$ is the decimal value in the Limiter Release Rate register and RATE is in LRCK's per 1/8 dB of change.

Note: A value of zero in this register is not recommended, as it will induce erratic behavior of the limiter. Use the LIM_EN bit to disable the limiter function (see *Peak Signal Limiter Enable (LIM_EN)*).

Binary Code	Decimal Value	LRCK's per 1/8 dB
00000001	1	512
00010100	20	25
00101000	40	12
00111100	60	8
01011010	90	5

Table 6. Example Limiter Release Rate Settings

4.10 Volume and Mixing Control (address 0Ah)

7	6	5	4	3	2	1	0
TC1	TC0	TC_EN	LIM_EN	ATAPI3	ATAPI2	ATAPI1	ATAPI0
0	0	0	0	1	0	0	1

4.10.1 TONE CONTROL MODE (TC)

Default = 00

00 - All settings are taken from user registers

01 - 12 dB of Bass Boost at 100 Hz and 6 dB of Treble Boost at 7 kHz

10 - 8 dB of Bass Boost at 100 Hz and 4 dB of Treble Boost at 7 kHz

11 - 4 dB of Bass Boost at 100 Hz and 2 dB of Treble Boost at 7 kHz

Function:

The Tone Control Mode bits determine how the Bass Boost and Treble Boost features are configured. The user defined settings from the Bass and Treble Boost Level and Corner Frequency registers are used when these bits are set to '00'. Alternately, one of three pre-defined settings may be used.

4.10.2 TONE CONTROL ENABLE (TC_EN)

Default = 0

0 - Disabled

1 - Enabled

Function:

The Bass Boost and Treble Boost features are active when this function is enabled.

4.10.3 PEAK SIGNAL LIMITER ENABLE (LIM_EN)

Default = 0
 0 - Disabled
 1 - Enabled

Function:

The CS43L42 will limit the maximum signal amplitude to prevent clipping when this function is enabled. Peak Signal Limiting is performed by first decreasing the Bass and Treble Boost Levels. If the signal is still clipping, the digital attenuation is increased. The attack rate is determined by the Limiter Attack Rate register.

Once the signal has dropped below the clipping level, the attenuation is decreased back to the user selected level followed by the Bass Boost being increased back to the user selected level. The release rate is determined by the Limiter Release Rate register.

Note: The A=B bit should be set to '1' for optimal limiter performance.

4.10.4 ATAPI CHANNEL MIXING AND MUTING (ATAPI)

Default = 1001 - AOUTA/HP_A = L, AOUTB/HP_B = R (Stereo)

Function:

The CS43L42 implements the channel mixing functions of the ATAPI CD-ROM specification. Refer to Table 7 and Figure 31 for additional information.

Note: All mixing functions occur prior to the digital volume control.

ATAPI3	ATAPI2	ATAPI1	ATAPI0	AOUTA/HP_A	AOUTB/HP_B
0	0	0	0	MUTE	MUTE
0	0	0	1	MUTE	R
0	0	1	0	MUTE	L
0	0	1	1	MUTE	[(L+R)/2]
0	1	0	0	R	MUTE
0	1	0	1	R	R
0	1	1	0	R	L
0	1	1	1	R	[(L+R)/2]
1	0	0	0	L	MUTE
1	0	0	1	L	R
1	0	1	0	L	L
1	0	1	1	L	[(L+R)/2]
1	1	0	0	[(L+R)/2]	MUTE
1	1	0	1	[(L+R)/2]	R
1	1	1	0	[(L+R)/2]	L
1	1	1	1	[(L+R)/2]	[(L+R)/2]

Table 7. ATAPI Decode

4.11 Mode Control 2 (address 0Bh)

7	6	5	4	3	2	1	0
MCLKDIV	LINE1	LINE0	RESERVED	RESERVED	DIF2	DIF1	DIF0
0	0	0	0	0	0	0	0

4.11.1 MASTER CLOCK DIVIDE ENABLE (MCLKDIV)

Default = 0

0 - Disabled

1 - Enabled

Function:

The MCLKDIV bit enables a circuit which divides the externally applied MCLK signal by 2 prior to all other internal circuitry.

Note: Internal SCLK is not available when this function is enabled.

4.11.2 LINE AMPLIFIER GAIN COMPENSATION (LINE)

Default = 00

00 - 0.785 x VA

01 - 0.943 x VA

10 - 1.571 x VA

11 - Line Mute

Function:

The Line Amplifier Gain Compensation bits allow the user to scale the full-scale line output level according to the power supply voltage used. The full-scale line output level will be equal to {gain factor}xVA, where {gain factor} is selected from options above. For example, if the user wants the full-scale line output voltage to be 1 V_{RMS} (2.8 V_{PP}) with VA = 1.8 VDC and VA_LINE = 3.0 VDC, then the gain factor would be 1.571.

Note: It is possible to exceed the maximum output level, limited by VA_LINE, by incorrectly setting the gain compensation factor.

The Line Mute option is available to allow muting of the line output when the headphone output is still in use and the line amp is still powered up. To use this feature, first mute the outputs via the ATAPI bits.

Next, set the LINE GAIN to Line Mute. Finally, un-mute the outputs with the ATAPI bits. Following these steps will ensure a click free mute.

4.11.3 DIGITAL INTERFACE FORMAT (DIF)

Default = 000 - Format 0 (I²S, up to 24-bit data, 64 x Fs Internal SCLK)

Function:

The required relationship between the Left/Right clock, serial clock and serial data is defined by the Digital Interface Format and the options are detailed in Figures 19-25.

Note: Internal SCLK is not available when MCLKDIV is enabled.

DIF2	DIF1	DIF0	DESCRIPTION	Format	FIGURE
0	0	0	I ² S, up to 24-bit data, 64 x Fs Internal SLCK	0	19
0	0	1	I ² S, up to 24-bit data, 32 x Fs Internal SLCK	1	20
0	1	0	Left Justified, up to 24-bit data,	2	21
0	1	1	Right Justified, 24-bit data	3	22
1	0	0	Right Justified, 20-bit data	4	23
1	0	1	Right Justified, 16-bit data	5	24
1	1	0	Right Justified, 18-bit data	6	25
1	1	1	Identical to Format 1	1	20

Table 8. Digital Interface Format

5. PIN DESCRIPTION

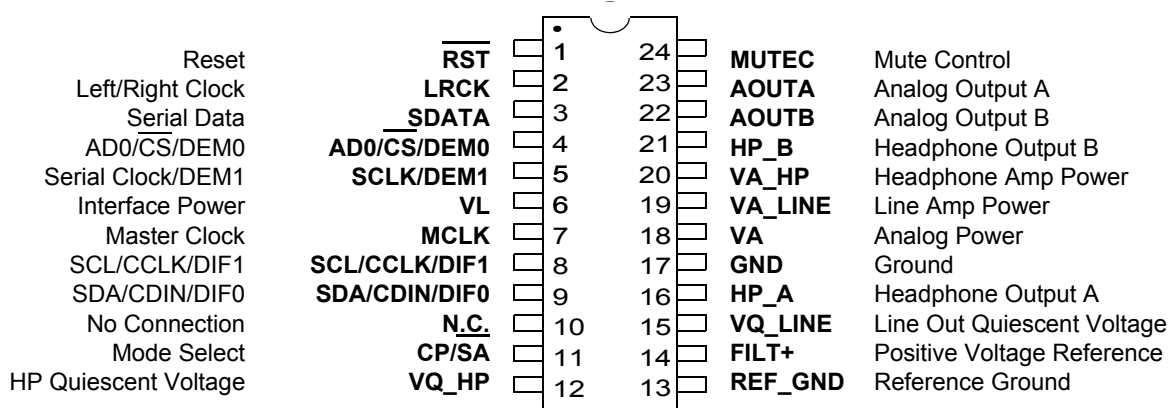

RST	1	Reset (Input) - The device enters a low power mode and all internal registers are reset to their default settings, including the control port, when low. When high, the control port becomes operational and the PDN bit must be cleared before normal operation will occur. The control port cannot be accessed when Reset is low.
LRCK	2	Left/Right Clock (Input) - Determines which channel is currently being input on the serial audio data input, SDATA. The frequency of the Left/Right clock must be equal to the input sample rate. Audio samples in Left/Right sample pairs will be simultaneously output from the digital-to-analog converter whereas Right/Left pairs will exhibit a one sample period difference. The required relationship between the Left/Right clock, serial clock and serial data is defined by the Mode Control 2 (0Bh) register when in Control Port Mode or by the DIF1-0 pins when in Stand-Alone mode. The options are detailed in Figures 19-29.
SDATA	3	Serial Audio Data (Input) - Two's complement MSB-first serial data is input on this pin. The data is clocked into SDATA via the serial clock and the channel is determined by the Left/Right clock. The required relationship between the Left/Right clock, serial clock and serial data is defined by the Mode Control 2 (0Bh) register when in Control Port Mode or by the DIF1-0 pins when in Stand-Alone mode. The options are detailed in Figures 19-29.
AD0/CS (Control Port Mode)	4	Address Bit / Chip Select (Input) - In Two-Wire mode, AD0 is a chip address bit. CS is used to enable the control port interface in SPI mode. The device will enter the SPI mode anytime a high to low transition is detected on this pin. Once the device has entered the SPI mode, it will remain in SPI mode until either the part is reset or power is removed.
SCLK	5	Serial Clock (Input) - Clocks the individual bits of the serial data into the SDATA pin. The required relationship between the Left/Right clock, serial clock and serial data is defined by the Mode Control 2 (0Bh) register when in Control Port Mode or by the DIF1-0 pins when in Stand-Alone mode. The options are detailed in Figures 19-29. The CS43L42 supports both internal and external serial clock generation modes. The Internal Serial Clock Mode eliminates possible clock interference from an external SCLK. Use of the Internal Serial Clock Mode is always preferred. Internal Serial Clock Mode - In the Internal Serial Clock Mode, the serial clock is internally derived and synchronous with the master clock and left/right clock. The SCLK/LRCK frequency ratio is either 32, 48, or 64 depending upon the Mode Control 2 (0Bh) register when in Control Port Mode or the DIF1-0 pins when in Stand-Alone mode as shown in Figures 19-29. Operation in this mode is identical to operation with an external serial clock synchronized with LRCK. External Serial Clock Mode - The CS43L42 will enter the External Serial Clock Mode whenever 16 low to high transitions are detected on the SCLK pin during any phase of the LRCK period. The device will revert to Internal Serial Clock Mode if no low to high transitions are detected on the SCLK pin for 2 consecutive periods of LRCK.

DEM0 and DEM1 (Stand-Alone Mode) 4 and 5 **De-emphasis Control (Input)** - Selects the appropriate digital filter to maintain the standard 15 μ s/50 μ s digital de-emphasis filter response at 32, 44.1 or 48 kHz sample rates. (see Figure 30) When using Internal Serial Clock Mode, Pin 5 is available for de-emphasis control, DEM1, and all de-emphasis filters are available. When using External Serial Clock Mode, Pin 5 is not available for de-emphasis use and only the 44.1 kHz de-emphasis filter is available. (see Table 9)

Note: De-emphasis is not available in High-Rate Mode.

Internal SCLK			External SCLK	
DEM1	DEMO	DESCRIPTION	DEMO	DESCRIPTION
0	0	Disabled	0	Disabled
0	1	44.1kHz	1	44.1 kHz
1	0	48kHz		
1	1	32kHz		

Table 9. Stand Alone De-Emphasis Control

VL 6 **Interface Power (Input)** - Digital interface power supply. Typically 1.8 to 3.3 VDC.

MCLK 7 **Master Clock (Input)** - Frequency must be either 256x, 384x, 512x, 768x or 1024x the input sample rate in Base Rate Mode (BRM) and 128x, 192x, 256x or 384x the input sample rate in High Rate Mode (HRM). Note that some multiplication factors require setting the MCLKDIV bit (see *Master Clock DIVIDE ENABLE (mclkdiv)*). Tables 10 and 11 illustrate several standard audio sample rates and the required master clock frequencies.

Sample Rate (kHz)	MCLK (MHz)			
	HRM			
	128x	192x	256x*	384x*
32	4.0960	6.1440	8.1920	12.2880
44.1	5.6448	8.4672	11.2896	16.9344
48	6.1440	9.2160	12.2880	18.4320
64	8.1920	12.2880	16.3840	24.5760
88.2	11.2896	16.9344	22.5792	33.8688
96	12.2880	18.4320	24.5760	36.8640

* Requires MCLKDIV bit = 1 in Mode Control 2 register (address 0Bh).

Table 10. HRM Common Clock Frequencies

Sample Rate (kHz)	MCLK (MHz)				
	BRM				
	256x	384x	512x	768x*	1024x*
32	8.1920	12.2880	16.3840	24.5760	32.7680
44.1	11.2896	16.9344	22.5792	32.7680	45.1584
48	12.2880	18.4320	24.5760	36.8640	49.1520

* Requires MCLKDIV bit = 1 in Mode Control 2 register (address 0Bh).

Table 11. BRM Common Clock Frequencies

SCL/CCLK (Control Port Mode) 8 **Serial Control Interface Clock (Input)** - Clocks the serial control data into or out of SDA/CDIN.

SDA/CDIN (Control Port Mode) 9 **Serial Control Data I/O (Input/Output)** - In Two-Wire mode, SDA is a data I/O line. CDIN is the input data line for the control port interface in SPI mode.

DIF1 and DIF0 (Stand-Alone Mode) 8 and 9 **Digital Interface Format (Input)** - The required relationship between the Left/Right clock, serial clock and serial data is defined by the Digital Interface Format and the options are detailed in Figures 26-29.

DIF1	DIF0	DESCRIPTION	FORMAT	FIGURE
0	0	I ² S, up to 24-bit data	0	26
0	1	Left Justified, up to 24-bit data	1	27
1	0	Right Justified, 24-bit Data	2	28
1	1	Right Justified, 16-bit Data	3	29

Table 12. Digital Interface Format - DIF1 and DIF0 (Stand-Alone Mode)

N.C.	10	No Connection - This pin has no internal connection to the device.
CP/SA	11	Mode Select (Input) - The Mode Select pin is used to select control port or stand-alone mode. When high, the CS43L42 will operate in control port mode. When low, the CS43L42 will operate in stand-alone mode.
VQ_HP	12	Headphone Quiescent Voltage (Output) - Filter connection for internal headphone amp quiescent reference voltage. A capacitor must be connected from VQ_HP to analog ground, as shown in Figure 6. VQ_HP is not intended to supply external current. VQ_HP has a typical source impedance of 250 kΩ and any current drawn from this pin will alter device performance.
REF_GND	13	Reference Ground (Input) - Ground reference for the internal sampling circuits. Must be connected to analog ground.
FILT+	14	Positive Voltage Reference (Output) - Positive reference for internal sampling circuits. An external capacitor is required from FILT+ to analog ground, as shown in Figure 6. The recommended value will typically provide 60 dB of PSRR at 1 kHz and 40 dB of PSRR at 60 Hz. FILT+ is not intended to supply external current. FILT+ has a typical source impedance of 250 kΩ and any current drawn from this pin will alter device performance.
VQ_LINE	15	Line Out Quiescent Voltage (Output) - Filter connection for internal line amp quiescent reference voltage. A capacitor must be connected from VQ_LINE to analog ground, as shown in Figure 6. VQ_LINE is not intended to supply external current. VQ_LINE has a typical source impedance of 250 kΩ and any current drawn from this pin will alter device performance.
HP_A and HP_B	16 and 21	Headphone Outputs (Output) - The full scale analog headphone output level is specified in the Analog Characteristics specifications table.
GND	17	Ground (Input) - Ground Reference. Should be connected to analog ground.
VA	18	Analog Power (Input) - Analog power supply. Typically 1.8 to 3.3 VDC.
VA_LINE	19	Line Amp Power (Input) - Line amplifier power supply. Typically 1.8 to 3.3 VDC. Note: If the line outputs are not used, connect VA_LINE to VA.
VA_HP	20	Headphone Amp Power (Input) - Headphone amplifier power supply. Typically 0.9 to 3.3 VDC.
AOUTA and AOUTB	22 and 23	Analog Outputs (Output) - The full scale analog line output level is specified in the Analog Characteristics specifications table.
MUTE_C	24	Mute Control (Output) - The Mute Control pin goes high during power-up initialization, reset, muting, power-down or if the master clock to left/right clock frequency ratio is incorrect. This pin is intended to be used as a control for an external mute circuit on the line outputs to prevent the clicks and pops that can occur in any single supply system. Use of Mute Control is not mandatory but recommended for designs requiring the absolute minimum in extraneous clicks and pops.

6. APPLICATIONS

6.1 Grounding and Power Supply Decoupling

As with any high resolution converter, the CS43L42 requires careful attention to power supply and grounding arrangements to optimize performance. Figure 6 shows the recommended power arrangement with VA, VA_HP, VA_LINE and VL connected to clean supplies. Decoupling capacitors should be located as close to the device package as possible. If desired, all supply pins may be connected to the same supply, but a decoupling capacitor should still be used on each supply pin.

6.2 Clock Modes

The CS43L42 operates in one of two clocking modes. Base Rate Mode supports input sample rates up to 50 kHz, and High Rate Mode supports input sample rates up to 100 kHz, see Table 10 and 11. All clock modes use 64x oversampling.

6.3 De-Emphasis

The CS43L42 includes on-chip digital de-emphasis. Figure 30 shows the de-emphasis curve for Fs equal to 44.1 kHz. The frequency response of the de-emphasis curve will scale proportionally with changes in sample rate, Fs.

The de-emphasis feature is included to accommodate older audio recordings that utilize pre-emphasis equalization as a means of noise reduction.

6.4 Recommended Power-up Sequence

- 1) Hold $\overline{\text{RST}}$ low until the power supply, master clock and left/right clock are stable. In this state, the control port is reset to its default settings and VQ_HP and VQ_LINE will remain low. Set the CP/ $\overline{\text{SA}}$ pin at this time.
- 2) Bring $\overline{\text{RST}}$ high. The device will remain in a low power state and latch CP/ $\overline{\text{SA}}$, and VQ_HP and VQ_LINE remain low. If CP/ $\overline{\text{SA}}$ is high, the control port will be accessible at this time

and the desired register settings can be loaded while keeping the PDN bit set to 1. If CP/ $\overline{\text{SA}}$ is low, the device will begin the stand-alone power-up sequence

- 3) (For Control Port Mode) Once the registers are configured as desired, set the PDN bit to 0, initiating the power-up sequence. This requires approximately 50 μs when the PopGuard[®] Transient Control (POR) bit is set to 0. If the POR bit is set to 1, see *PopGuard[®] Transient Control* for total power-up timing.

6.5 PopGuard[®] Transient Control

The CS43L42 uses PopGuard[®] technology to minimize the effects of output transients during power-up and power-down. This technique minimizes the audio transients commonly produced by single-ended, single-supply converters when it is implemented with external DC-blocking capacitors connected in series with the audio outputs.

When the device is initially powered-up, the audio outputs, AOUTA, AOUTB, HP_A and HP_B are clamped to GND. Following a delay of approximately 1000 sample periods, each output begins to ramp toward the quiescent voltage. Approximately 10,000 left/right clock cycles later, the outputs reach VQ_LINE and VQ_HP respectively, and audio output begins. This gradual voltage ramping allows time for the external DC-blocking capacitor to charge to the quiescent voltage, minimizing the power-up transient.

To prevent transients at power-down, the device must first enter its power-down state. When this occurs, audio output ceases and the internal output buffers are disconnected from AOUTA, AOUTB, HP_A and HP_B. In their place, a soft-start current sink is substituted which allows the DC-blocking capacitors to slowly discharge. Once this charge is dissipated, the power to the device may be turned off, and the system is ready for the next power-on.

To prevent an audio transient at the next power-on, the DC-blocking capacitors must fully discharge before turning off the power or exiting the power-down state. If full discharge does not occur, a transient will occur when the audio outputs are initially clamped to GND. The time that the device must remain in the power-down state is related to the value of the DC-blocking capacitance and the output load. For example, with a 220 μF capacitor and a 16 ohm load on the headphone outputs, the minimum power-down time will be approximately 0.4 seconds.

Use of the Mute Control function on the line outputs is recommended for designs requiring the absolute minimum in extraneous clicks and pops. Also, use of the Mute Control function can enable the system designer to achieve idle channel noise/signal-to-noise ratios only limited by the external mute circuit. See the CDB43L42 Datasheet for a suggested mute circuit.

7. CONTROL PORT INTERFACE

The control port is used to load all the internal settings. The operation of the control port may be completely asynchronous with the audio sample rate. However, to avoid potential interference problems, the control port pins should remain static if no operation is required.

The control port has 2 modes: SPI and Two-Wire, with the CS43L42 operating as a slave device. If Two-Wire operation is desired, AD0/ $\overline{\text{CS}}$ should be tied to VL or GND. If the CS43L42 ever detects a high to low transition on AD0/ $\overline{\text{CS}}$ after power-up, SPI mode will be selected.

7.1 SPI Mode

In SPI mode, $\overline{\text{CS}}$ is the CS43L42 chip select signal, CCLK is the control port bit clock, CDIN is the input data line from the microcontroller and the chip address is 0010000. All signals are inputs and data is clocked in on the rising edge of CCLK. Figure 7 shows the operation of the control port in SPI

mode. To write to a register, bring $\overline{\text{CS}}$ low. The first 7 bits on CDIN form the chip address and must be 0010000. The eighth bit is a read/write indicator ($\text{R}/\overline{\text{W}}$), which must be low to write. The next 8 bits form the Memory Address Pointer (MAP), which is set to the address of the register that is to be updated. The next 8 bits are the data which will be placed into register designated by the MAP.

The CS43L42 has a MAP auto increment capability, enabled by the INCR bit in the MAP register. If INCR is a zero, then the MAP will stay constant for successive writes. If INCR is set to a 1, then MAP will auto increment after each byte is written, allowing block writes of successive registers.

7.2 Two-Wire Mode

In Two-Wire mode, SDA is a bidirectional data line. Data is clocked into and out of the part by the clock, SCL, with the clock to data relationship as shown in Figure 8. There is no $\overline{\text{CS}}$ pin. Pin AD0 forms the partial chip address and should be tied to VL or GND as required. The upper 6 bits of the 7 bit address field must be 001000. To communicate with the CS43L42, the LSB of the chip address field, which is the first byte sent to the CS43L42, should match the setting of the AD0 pin. The eighth bit of the address byte is the $\text{R}/\overline{\text{W}}$ bit (high for a read, low for a write). If the operation is a write, the next byte is the Memory Address Pointer, MAP, which selects the register to be read or written. The MAP is then followed by the data to be written. If the operation is a read, the contents of the register pointed to by the MAP will be output after the chip address.

The CS43L42 has MAP auto increment capability, enabled by the INCR bit in the MAP register. If INCR is 0, then the MAP will stay constant for successive writes. If INCR is set to 1, then MAP will auto increment after each byte is written, allowing block reads or writes of successive registers.

The Two-Wire mode is compatible with the I²C protocol.

7.3 Memory Address Pointer (MAP)

7	6	5	4	3	2	1	0
INCR	Reserved	Reserved	Reserved	MAP3	MAP2	MAP1	MAP0
0	0	0	0	0	0	0	0

7.3.1 INCR (AUTO MAP INCREMENT ENABLE)

Default = '0'
 0 - Disabled
 1 - Enabled

7.3.2 MAP0-3 (MEMORY ADDRESS POINTER)

Default = '0000'

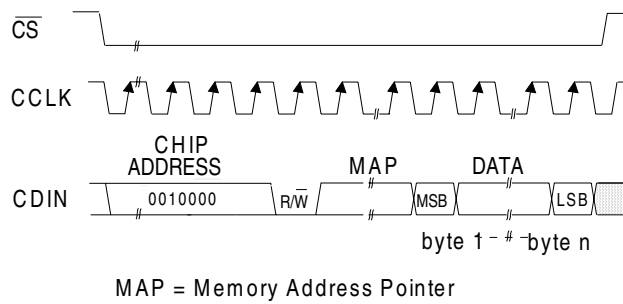
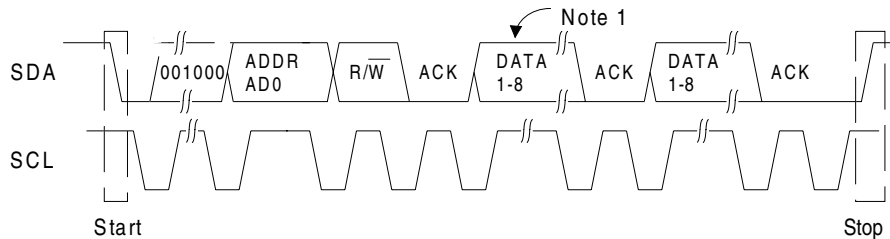

Figure 7. Control Port Timing, SPI mode



Note: If operation is a write, this byte contains the Memory Address Pointer, MAP.

Figure 8. Control Port Timing, Two-Wire Mode

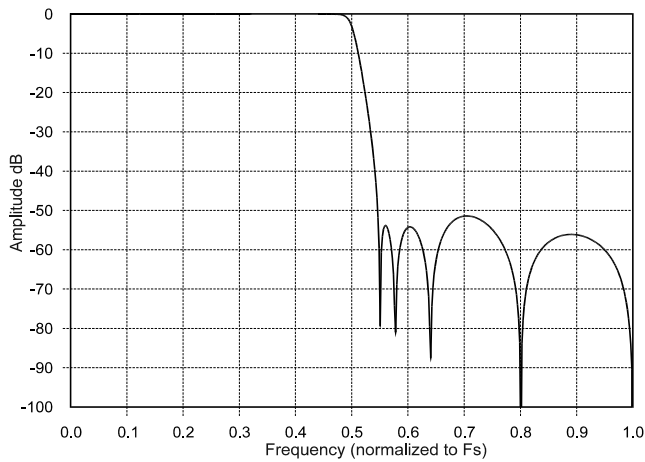

Figure 9. Base-Rate Stopband Rejection

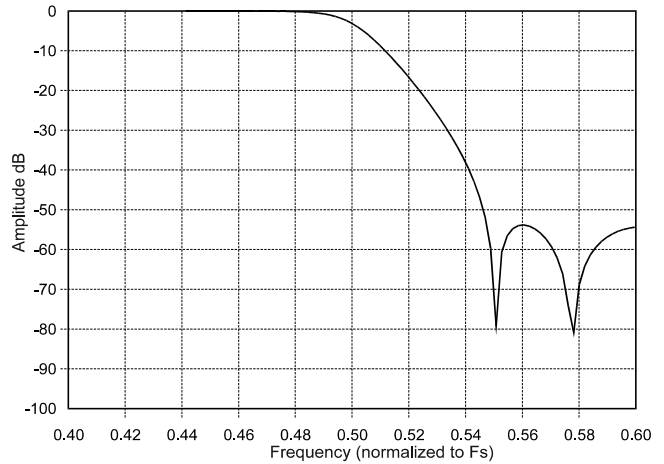

Figure 10. Base-Rate Transition Band

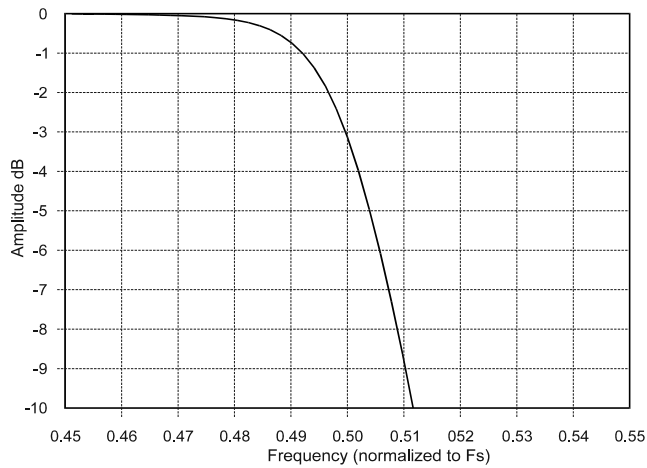

Figure 11. Base-Rate Transition Band (Detail)

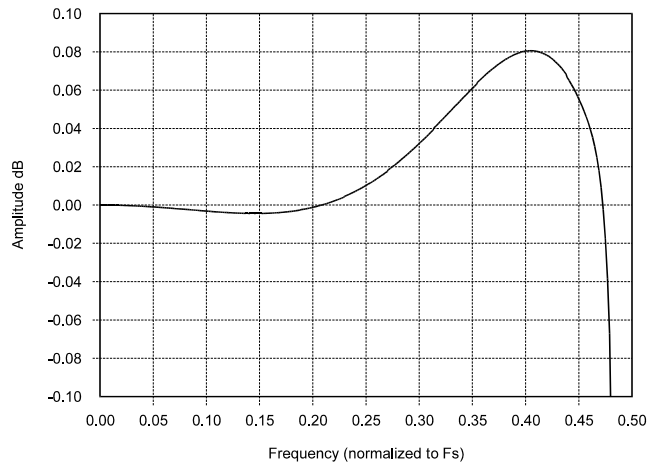

Figure 12. Base-Rate Passband Ripple

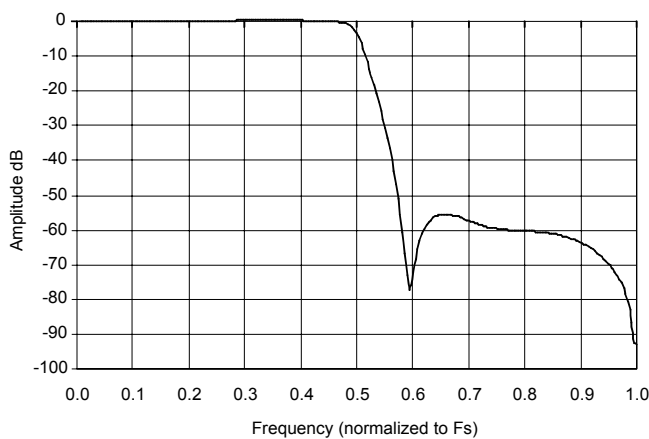

Figure 13. High-Rate Stopband Rejection

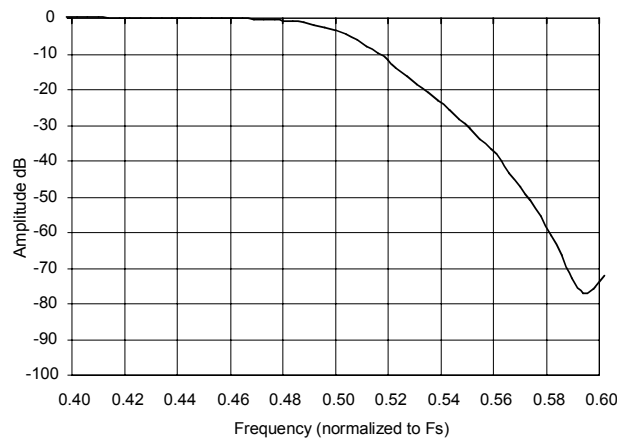

Figure 14. High-Rate Transition Band

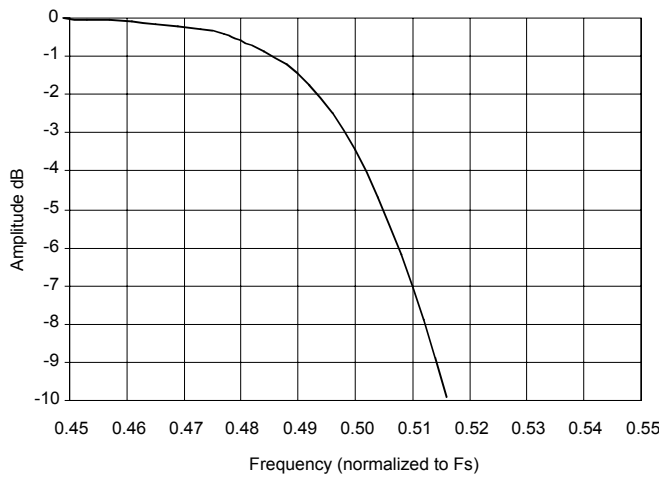

Figure 15. High-Rate Transition Band (Detail)

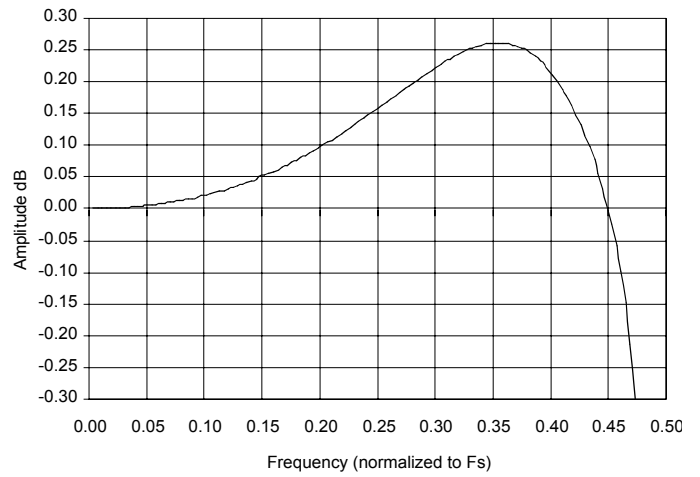

Figure 16. High-Rate Passband Ripple

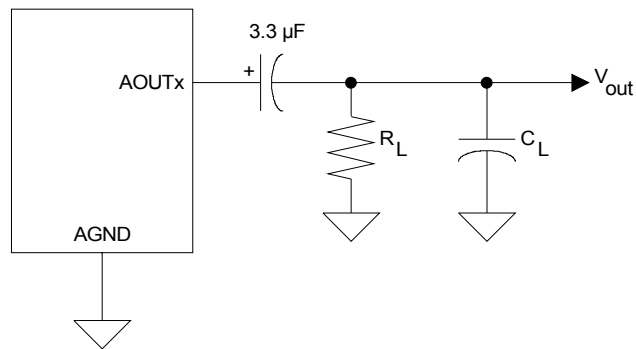

Figure 17. Line Output Test Load

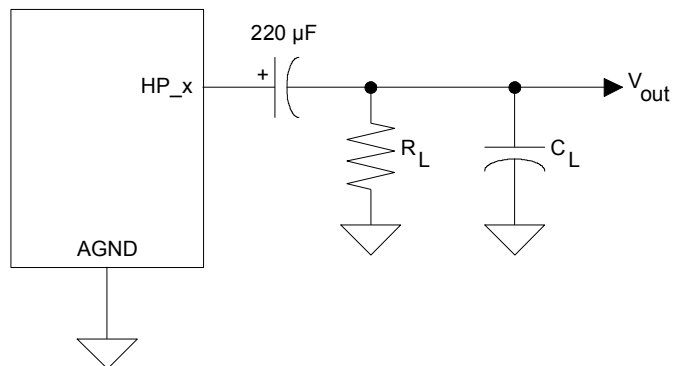
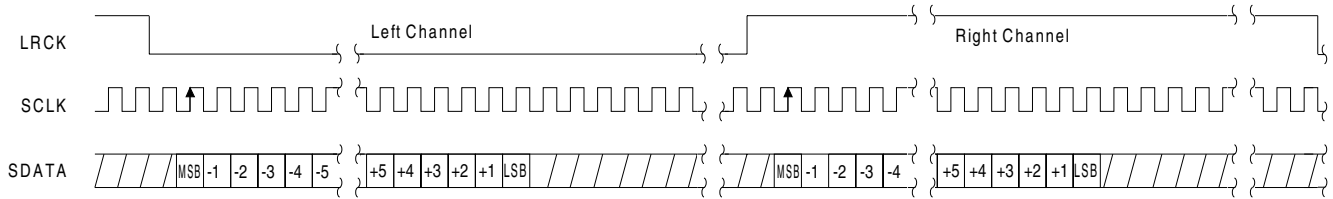
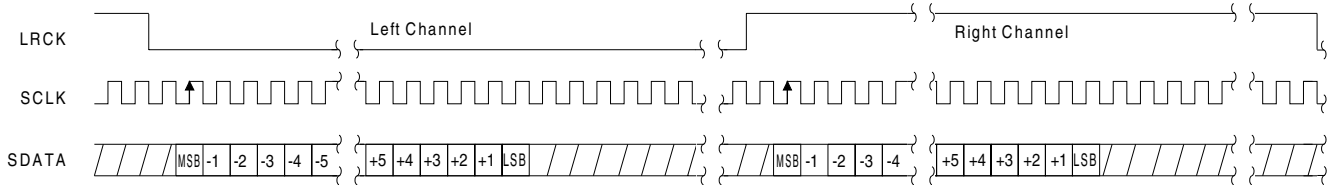

Figure 18. Headphone Output Test Load



Internal SCLK Mode	External SCLK Mode
I^2S , Up to 24-Bit data and INT SCLK = 64 Fs if MCLK/LRCK = 512, 256 or 128 I^2S , Up to 24-Bit data and INT SCLK = 48 Fs if MCLK/LRCK = 384 or 192	I^2S , up to 24-Bit Data Data Valid on Rising Edge of SCLK

Figure 19. CS43L42 Control Port Mode - Serial Audio Format 0

Internal SCLK Mode	External SCLK Mode
I^2S , 16-Bit data and INT SCLK = 32 Fs if MCLK/LRCK = 512, 256 or 128 I^2S , Up to 24-Bit data and INT SCLK = 48 Fs if MCLK/LRCK = 384 or 192	I^2S , up to 24-Bit Data Data Valid on Rising Edge of SCLK

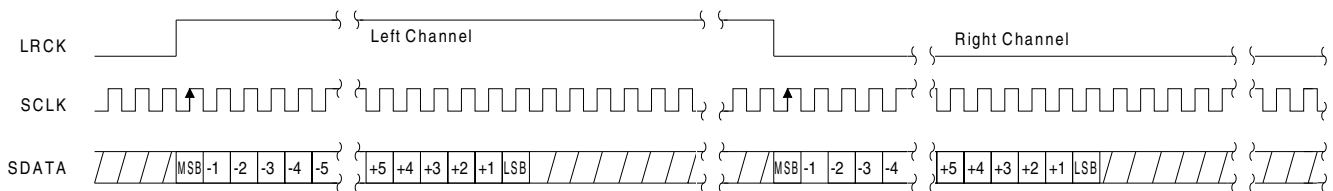
Figure 20. CS43L42 Control Port Mode - Serial Audio Format 1

Internal SCLK Mode	External SCLK Mode
Left Justified, up to 24-Bit Data INT SCLK = 64 Fs if MCLK/LRCK = 512, 256 or 128 INT SCLK = 48 Fs if MCLK/LRCK = 384 or 192	Left Justified, up to 24-Bit Data Data Valid on Rising Edge of SCLK

Figure 21. CS43L42 Control Port Mode - Serial Audio Format 2

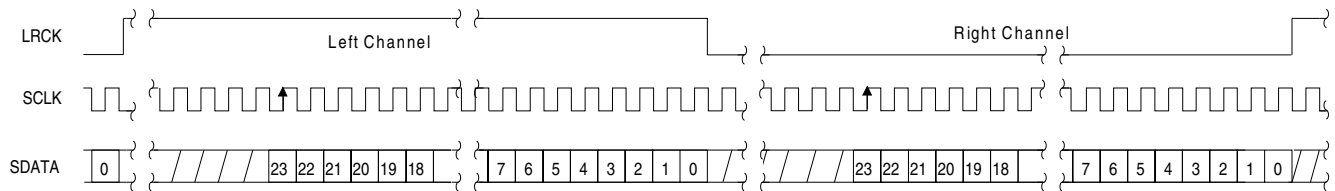

Internal SCLK Mode	External SCLK Mode
Right Justified, 24-Bit Data INT SCLK = 64 Fs if MCLK/LRCK = 512, 256 or 128 INT SCLK = 48 Fs if MCLK/LRCK = 384 or 192	Right Justified, 24-Bit Data Data Valid on Rising Edge of SCLK SCLK Must Have at Least 48 Cycles per LRCK Period

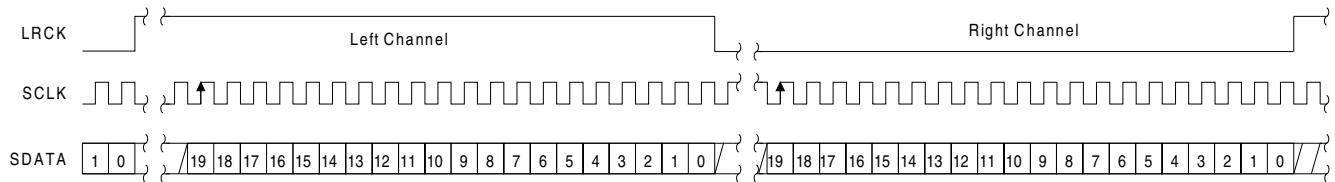
Figure 22. CS43L42 Control Port Mode - Serial Audio Format 3

Internal SCLK Mode	External SCLK Mode
Right Justified, 20-Bit Data INT SCLK = 64 Fs if MCLK/LRCK = 512, 256 or 128 INT SCLK = 48 Fs if MCLK/LRCK = 384 or 192	Right Justified, 20-Bit Data Data Valid on Rising Edge of SCLK SCLK Must Have at Least 40 Cycles per LRCK Period

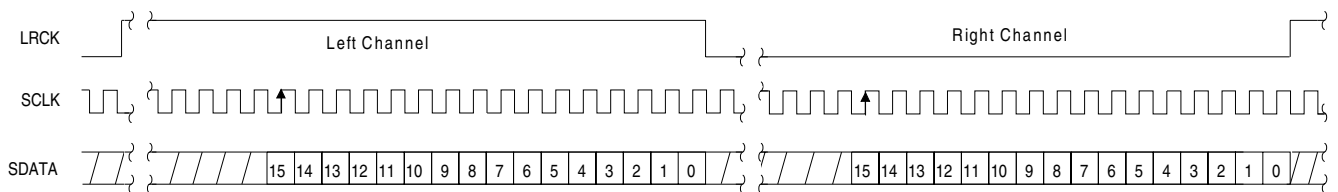
Figure 23. CS43L42 Control Port Mode - Serial Audio Format 4

Internal SCLK Mode	External SCLK Mode
Right Justified, 16-Bit Data INT SCLK = 32 Fs if MCLK/LRCK = 512, 256 or 128 INT SCLK = 48 Fs if MCLK/LRCK = 384 or 192	Right Justified, 16-Bit Data Data Valid on Rising Edge of SCLK SCLK Must Have at Least 32 Cycles per LRCK Period

Figure 24. CS43L42 Control Port Mode - Serial Audio Format 5

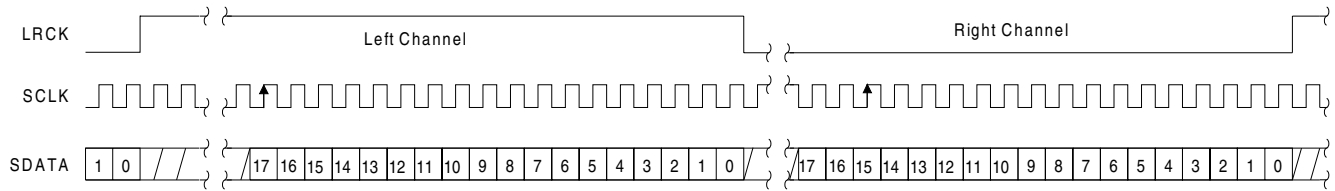

Internal SCLK Mode	External SCLK Mode
Right Justified, 18-Bit Data INT SCLK = 64 Fs if MCLK/LRCK = 512, 256 or 128 INT SCLK = 48 Fs if MCLK/LRCK = 384 or 192	Right Justified, 18-Bit Data Data Valid on Rising Edge of SCLK SCLK Must Have at Least 36 Cycles per LRCK Period

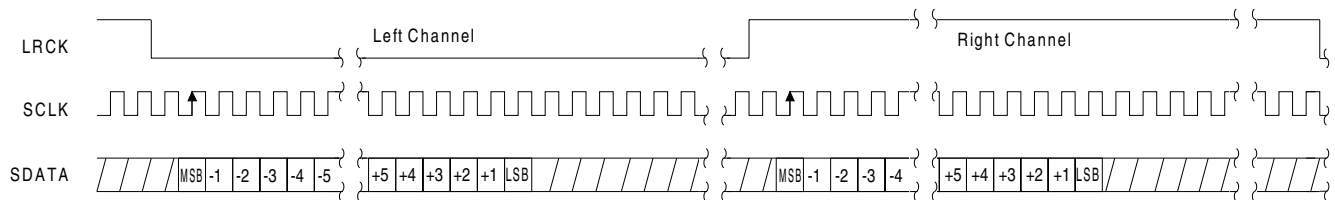
Figure 25. CS43L42 Control Port Mode - Serial Audio Format 6

Internal SCLK Mode	External SCLK Mode
I ² S, Up to 24-Bit data and INT SCLK = 64 Fs if MCLK/LRCK = 512, 256 or 128 I ² S, Up to 24-Bit data and INT SCLK = 48 Fs if MCLK/LRCK = 384 or 192	I ² S, up to 24-Bit Data Data Valid on Rising Edge of SCLK

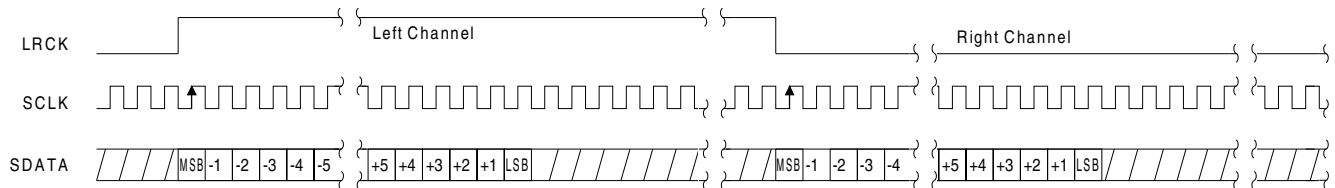
Figure 26. CS43L42 Stand Alone Mode - Serial Audio Format 0

Internal SCLK Mode	External SCLK Mode
Left Justified, up to 24-Bit Data INT SCLK = 64 Fs if MCLK/LRCK = 512, 256 or 128 INT SCLK = 48 Fs if MCLK/LRCK = 384 or 192	Left Justified, up to 24-Bit Data Data Valid on Rising Edge of SCLK

Figure 27. CS43L42 Stand Alone Mode - Serial Audio Format 1

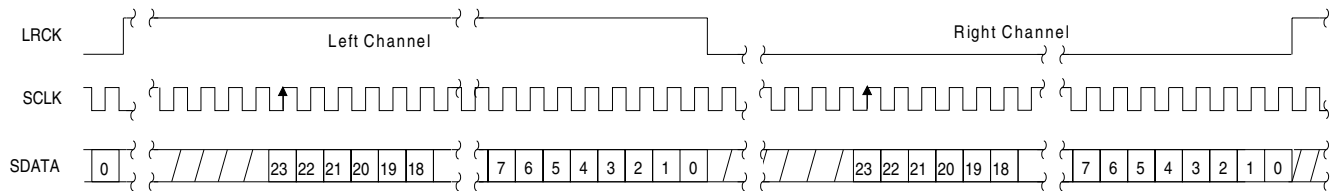

Internal SCLK Mode	External SCLK Mode
Right Justified, 24-Bit Data INT SCLK = 64 Fs if MCLK/LRCK = 512, 256 or 128 INT SCLK = 48 Fs if MCLK/LRCK = 384 or 192	Right Justified, 24-Bit Data Data Valid on Rising Edge of SCLK SCLK Must Have at Least 48 Cycles per LRCK Period

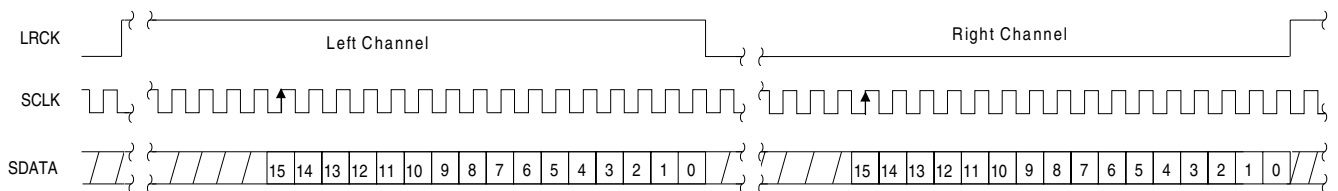
Figure 28. CS43L42 Stand Alone Mode - Serial Audio Format 2

Internal SCLK Mode	External SCLK Mode
Right Justified, 16-Bit Data INT SCLK = 32 Fs if MCLK/LRCK = 512, 256 or 128 INT SCLK = 48 Fs if MCLK/LRCK = 384 or 192	Right Justified, 16-Bit Data Data Valid on Rising Edge of SCLK SCLK Must Have at Least 32 Cycles per LRCK Period

Figure 29. CS43L42 Stand Alone Mode - Serial Audio Format 3

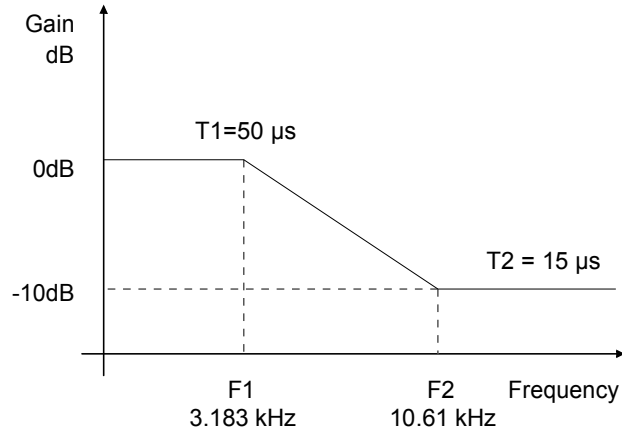

Figure 30. De-Emphasis Curve

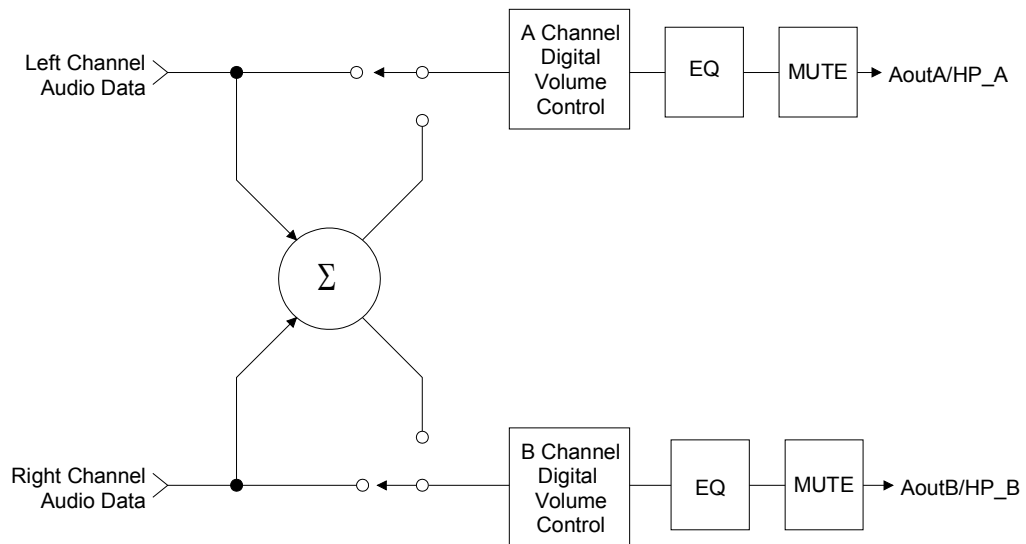

Figure 31. ATAPI Block Diagram

8. PARAMETER DEFINITIONS

Total Harmonic Distortion + Noise (THD+N)

The ratio of the rms value of the signal to the rms sum of all other spectral components over the specified bandwidth (typically 10 Hz to 20 kHz), including distortion components. Expressed in decibels.

Dynamic Range

The ratio of the full scale rms value of the signal to the rms sum of all other spectral components over the specified bandwidth. Dynamic range is a signal-to-noise measurement over the specified bandwidth made with a -60 dBFS signal. 60 dB is then added to the resulting measurement to refer the measurement to full scale. This technique ensures that the distortion components are below the noise level and do not effect the measurement. This measurement technique has been accepted by the Audio Engineering Society, AES17-1991, and the Electronic Industries Association of Japan, EIAJ CP-307.

Interchannel Isolation

A measure of crosstalk between the left and right channels. Measured for each channel at the converter's output with all zeros to the input under test and a full-scale signal applied to the other channel. Units in decibels.

Interchannel Gain Mismatch

The gain difference between left and right channels. Units in decibels.

Gain Error

The deviation from the nominal full scale analog output for a full scale digital input.

Gain Drift

The change in gain value with temperature. Units in ppm/°C.

9. REFERENCES

- 1) "How to Achieve Optimum Performance from Delta-Sigma A/D & D/A Converters" by Steven Harris. Paper presented at the 93rd Convention of the Audio Engineering Society, October 1992.
- 2) CDB43L42 Evaluation Board Datasheet
- 3) "The I²C-Bus Specification: Version 2.0" Philips Semiconductors, December 1998.
<http://www.semiconductors.philips.com>

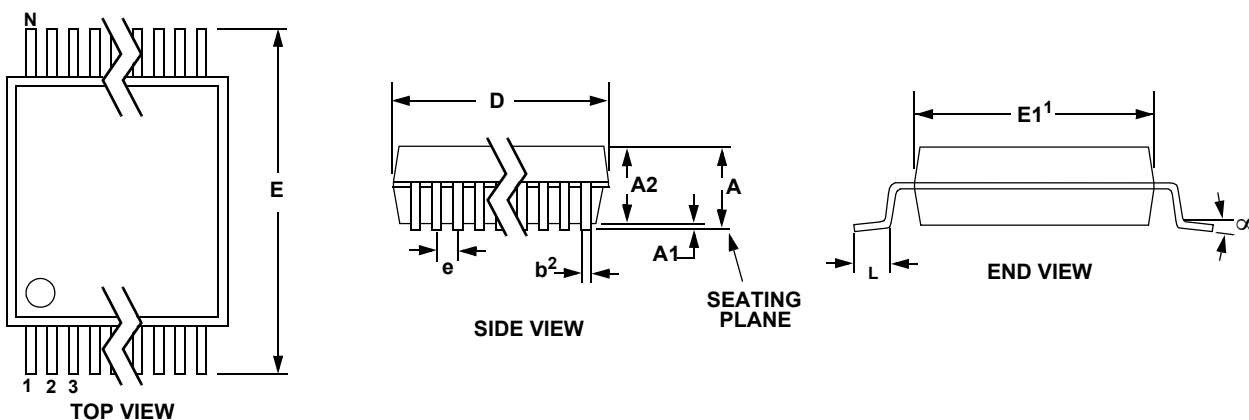
10. PACKAGE DIMENSIONS
24L TSSOP (4.4 mm BODY) PACKAGE DRAWING

DIM	INCHES			MILLIMETERS			NOTE
	MIN	NOM	MAX	MIN	NOM	MAX	
A	--	--	0.043	--	--	1.10	
A1	0.002	0.004	0.006	0.05	--	0.15	
A2	0.03346	0.0354	0.037	0.85	0.90	0.95	
b	0.00748	0.0096	0.012	0.19	0.245	0.30	2,3
D	0.303	0.307	0.311	7.70	7.80	7.90	1
E	0.248	0.2519	0.256	6.30	6.40	6.50	
E1	0.169	0.1732	0.177	4.30	4.40	4.50	1
e	--	0.026 BSC	--	--	0.65 BSC	--	
L	0.020	0.024	0.028	0.50	0.60	0.70	
α	0°	4°	8°	0°	4°	8°	

JEDEC #: MO-153
Controlling Dimension is Millimeters.

- Notes:
1. "D" and "E1" are reference datums and do not include mold flash or protrusions, but do include mold mismatch and are measured at the parting line, mold flash or protrusions shall not exceed 0.20 mm per side.
 2. Dimension "b" does not include dambar protrusion/intrusion. Allowable dambar protrusion shall be 0.13 mm total in excess of "b" dimension at maximum material condition. Dambar intrusion shall not reduce dimension "b" by more than 0.07 mm at least material condition.
 3. These dimensions apply to the flat section of the lead between 0.10 and 0.25 mm from lead tips.