

- Replaces SN74AS305
- Maximum Output Skew of 1 ns
- Maximum Pulse Skew of 1 ns
- TTL-Compatible Inputs and Outputs
- Center-Pin V_{CC} and GND Configurations Minimize High-Speed Switching Noise
- Package Options Include Plastic Small-Outline (D) Package and Standard Plastic (N) 300-mil DIPs

D OR N PACKAGE
(TOP VIEW)

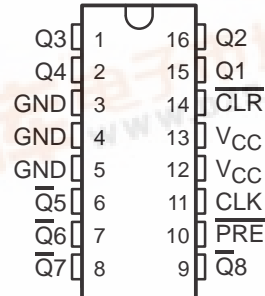

description

The CDC305 contains eight flip-flops designed to have low skew between outputs. The eight outputs (four in-phase with CLK and four out-of-phase) toggle on successive CLK pulses. Preset (\overline{PRE}) and clear (\overline{CLR}) inputs are provided to set the Q and \overline{Q} outputs high or low independent of the clock (CLK) input.

The CDC305 has output and pulse-skew parameters $t_{sk(o)}$ and $t_{sk(p)}$ to ensure performance as a clock driver when a divide-by-two function is required.

The CDC305 is characterized for operation from 0°C to 70°C.

FUNCTION TABLE

INPUTS			OUTPUTS	
\overline{CLR}	\overline{PRE}	CLK	Q1–Q4	$\overline{Q5}$ – $\overline{Q8}$
L	H	X	L	H
H	L	X	H	L
L	L	X	L†	L†
H	H	L	Q ₀	\overline{Q}_0
H	H	↑	\overline{Q}_0	Q ₀

† This configuration does not persist when \overline{PRE} or \overline{CLR} returns to its inactive (high) level.

Please be aware that an important notice concerning availability, standard warranty, and use in critical applications of Texas Instruments semiconductor products and disclaimers thereto appears at the end of this data sheet.

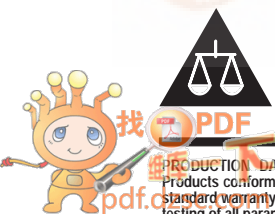

CDC305 OCTAL DIVIDE-BY-2 CIRCUIT/CLOCK DRIVER

SCAS326A – JUNE 1990 – REVISED NOVEMBER 1995

logic symbol†

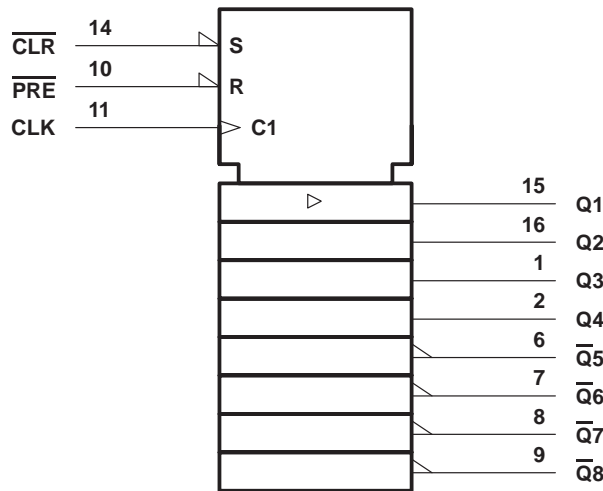

† This symbol is in accordance with ANSI/IEEE Std 91-1984 and IEC Publication 617-12.

logic diagram (positive logic)

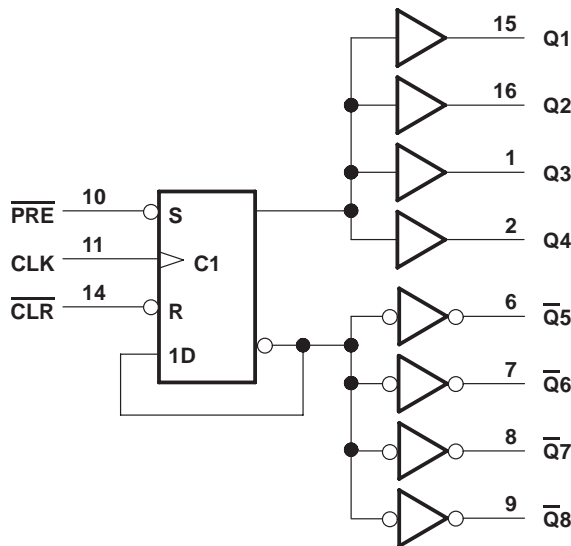

absolute maximum ratings over operating free-air temperature range (unless otherwise noted)‡

Supply voltage, V_{CC}	7 V
Input voltage, V_I	7 V
Maximum power dissipation at $T_A = 55^\circ\text{C}$ (in still air) (see Note 1): D package	0.77 W
N package	1.2 W
Storage temperature range, T_{stg}	-65°C to 150°C

‡ Stresses beyond those listed under “absolute maximum ratings” may cause permanent damage to the device. These are stress ratings only and functional operation of the device at these or any other conditions beyond those indicated under “recommended operating conditions” is not implied. Exposure to absolute-maximum-rated conditions for extended periods may affect device reliability.

NOTE 1: The maximum package power dissipation is calculated using a junction temperature of 150°C and a board trace length of 300 mils, except for the N package, which has a trace length of zero. For more information, refer to the *Package Thermal Considerations* application note in the 1994 *ABT Advanced BiCMOS Technology Data Book*, literature number SCBD002B.

CDC305 OCTAL DIVIDE-BY-2 CIRCUIT/CLOCK DRIVER

SCAS326A – JUNE 1990 – REVISED NOVEMBER 1995

recommended operating conditions

		MIN	NOM	MAX	UNIT
V_{CC}	Supply voltage	4.5	5	5.5	V
V_{IH}	High-level input voltage	2			V
V_{IL}	Low-level input voltage			0.8	V
I_{OH}	High-level output current			-24	mA
I_{OL}	Low-level output current			48	mA
T_A	Operating free-air temperature	0		70	°C

electrical characteristics over recommended operating free-air temperature range (unless otherwise noted)

PARAMETER	TEST CONDITIONS	MIN	TYP†	MAX	UNIT
V_{IK}	$V_{CC} = 4.5\text{ V}$, $I_I = -18\text{ mA}$			-1.2	V
V_{OH}	$V_{CC} = 4.5\text{ V to } 5.5\text{ V}$, $I_{OH} = -2\text{ mA}$	$V_{CC} - 2$			V
	$V_{CC} = 4.5\text{ V}$, $I_{OH} = -24\text{ mA}$	2	2.8		
V_{OL}	$V_{CC} = 4.5\text{ V}$, $I_{OL} = 48\text{ mA}$		0.3	0.5	V
I_I	$V_{CC} = 5.5\text{ V}$, $V_I = 7\text{ V}$			0.1	mA
I_{IH}	$V_{CC} = 5.5\text{ V}$, $V_I = 2.7\text{ V}$			20	μA
I_{IL}	$V_{CC} = 5.5\text{ V}$, $V_I = 0.4\text{ V}$			-0.5	mA
$I_{O\ddagger}$	$V_{CC} = 5.5\text{ V}$, $V_O = 2.25\text{ V}$	-50		-150	mA
I_{CC}	$V_{CC} = 5.5\text{ V}$, See Note 2		40	70	mA

† All typical values are at $V_{CC} = 5\text{ V}$, $T_A = 25^\circ\text{C}$.

‡ The output conditions have been chosen to produce a current that closely approximates one half of the true short-circuit output current, I_{OS} .

NOTE 2: I_{CC} is measured with CLK and PRE grounded, then with CLK and CLR grounded.

timing requirements over recommended ranges of supply voltage and operating free-air temperature

		MIN	MAX	UNIT	
f_{clock}	Clock frequency	0	80	MHz	
t_w	Pulse duration	$\overline{\text{CLR}}$ or $\overline{\text{PRE}}$ low	5	ns	
		CLK high	4		
		CLK low	6		
t_{su}	Setup time before CLK↑	$\overline{\text{CLR}}$ or $\overline{\text{PRE}}$ inactive		6	ns

CDC305 OCTAL DIVIDE-BY-2 CIRCUIT/CLOCK DRIVER

SCAS326A – JUNE 1990 – REVISED NOVEMBER 1995

switching characteristics over recommended ranges of supply voltage and operating free-air temperature (unless otherwise noted) (see Figure 1)

PARAMETER	FROM (INPUT)	TO (OUTPUT)	TEST CONDITIONS	MIN	TYP†	MAX	UNIT
$f_{max}‡$				80			MHz
t_{PLH}	CLK	Q, \bar{Q}	$R_L = 500 \Omega, C_L = 50 \text{ pF}$	2	6	9	ns
t_{PHL}				2	6	9	
t_{PLH}	\overline{PRE} or \overline{CLR}	Q, \bar{Q}	$R_L = 500 \Omega, C_L = 50 \text{ pF}$	3	7	12	ns
t_{PHL}				3	7	12	
$t_{sk(o)}$	CLK	\bar{Q}	$R_L = 500 \Omega, C_L = 10 \text{ pF to } 30 \text{ pF},$ See Figure 2			1	ns
		Q				1	
		Q1– \bar{Q} 8				1.5	
$t_{sk(p)}$	CLK	Q1, \bar{Q} 8	$R_L = 500 \Omega, C_L = 10 \text{ pF to } 30 \text{ pF}$			1.5	ns
		Q2– \bar{Q} 7				2	
t_r						4.5	ns
t_f						3.5	ns

† All typical values are at $V_{CC} = 5 \text{ V}, T_A = 25^\circ\text{C}$.

‡ f_{max} minimum values are at $C_L = 0 \text{ to } 30 \text{ pF}$.

PARAMETER MEASUREMENT INFORMATION

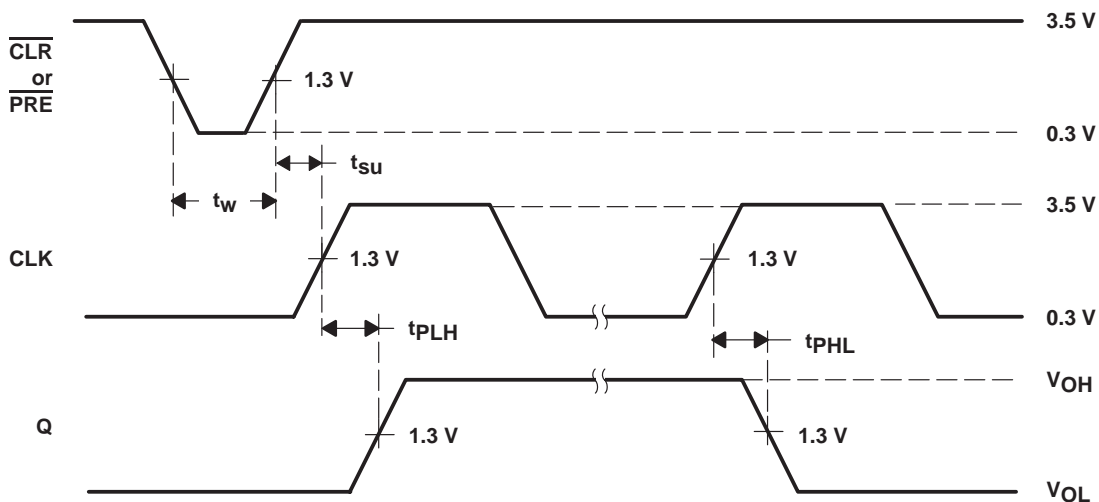
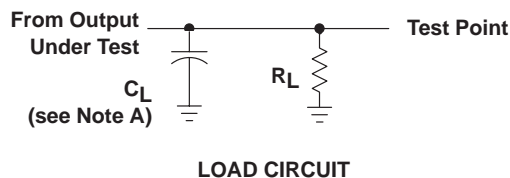

NOTES: A. C_L includes probe and jig capacitance.

B. Input pulses are supplied by generators having the following characteristics: $PRR \leq 10 \text{ MHz}, t_r = 2.5 \text{ ns}, t_f = 2.5 \text{ ns}$.

Figure 1. Load Circuit and Voltage Waveforms

PARAMETER MEASUREMENT INFORMATION

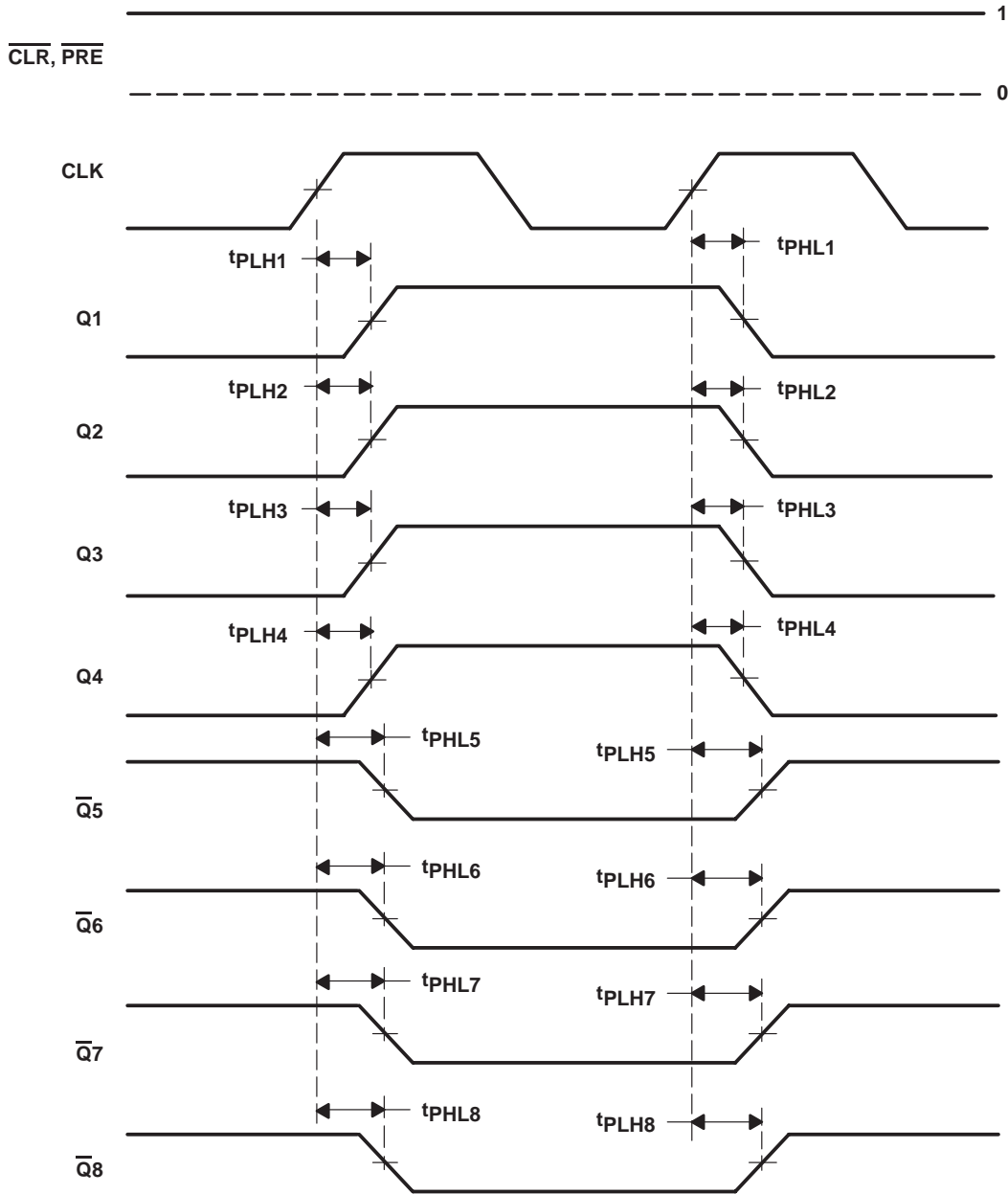

- NOTES: A. $t_{\text{sk}(o)}$ CLK to Q are calculated as the greater of:
- The difference between the fastest and slowest of $t_{\text{PLH}n}$ ($n = 1, 2, 3, 4$)
 - The difference between the fastest and slowest of $t_{\text{PHL}n}$ ($n = 1, 2, 3, 4$)
- B. $t_{\text{sk}(o)}$ CLK to $\overline{\text{Q}}$ are calculated as the greater of:
- The difference between the fastest and slowest of $t_{\text{PLH}n}$ ($n = 5, 6, 7, 8$)
 - The difference between the fastest and slowest of $t_{\text{PHL}n}$ ($n = 5, 6, 7, 8$)
- C. $t_{\text{sk}(o)}$ CLK to Q and $\overline{\text{Q}}$ are calculated as the greater of:
- The difference between the fastest and slowest of $t_{\text{PLH}n}$ ($n = 1, 2, 3, 4$), $t_{\text{PHL}n}$ ($n = 5, 6, 7, 8$)
 - The difference between the fastest and slowest of $t_{\text{PHL}n}$ ($n = 1, 2, 3, 4$), $t_{\text{PLH}n}$ ($n = 5, 6, 7, 8$)
- D. $t_{\text{sk}(p)}$ is calculated as the greater of $|t_{\text{PLH}n} - t_{\text{PHL}n}|$ ($n = 1, 2, 3, \dots, 8$).

Figure 2. Waveforms for Calculation of $t_{\text{sk}(o)}$ and $t_{\text{sk}(p)}$

PACKAGING INFORMATION

Orderable Device	Status ⁽¹⁾	Package Type	Package Drawing	Pins	Package Qty	Eco Plan ⁽²⁾	Lead/Ball Finish	MSL Peak Temp ⁽³⁾
CDC305-1N	OBSOLETE	PDIP	N	16		TBD	Call TI	Call TI
CDC305D	OBSOLETE	SOIC	D	16		TBD	Call TI	Call TI
CDC305DR	OBSOLETE	SOIC	D	16		TBD	Call TI	Call TI
CDC305N	OBSOLETE	PDIP	N	16		TBD	Call TI	Call TI

⁽¹⁾ The marketing status values are defined as follows:

ACTIVE: Product device recommended for new designs.

LIFEBUY: TI has announced that the device will be discontinued, and a lifetime-buy period is in effect.

NRND: Not recommended for new designs. Device is in production to support existing customers, but TI does not recommend using this part in a new design.

PREVIEW: Device has been announced but is not in production. Samples may or may not be available.

OBSOLETE: TI has discontinued the production of the device.

⁽²⁾ Eco Plan - The planned eco-friendly classification: Pb-Free (RoHS) or Green (RoHS & no Sb/Br) - please check <http://www.ti.com/productcontent> for the latest availability information and additional product content details.

TBD: The Pb-Free/Green conversion plan has not been defined.

Pb-Free (RoHS): TI's terms "Lead-Free" or "Pb-Free" mean semiconductor products that are compatible with the current RoHS requirements for all 6 substances, including the requirement that lead not exceed 0.1% by weight in homogeneous materials. Where designed to be soldered at high temperatures, TI Pb-Free products are suitable for use in specified lead-free processes.

Green (RoHS & no Sb/Br): TI defines "Green" to mean Pb-Free (RoHS compatible), and free of Bromine (Br) and Antimony (Sb) based flame retardants (Br or Sb do not exceed 0.1% by weight in homogeneous material)

⁽³⁾ MSL, Peak Temp. -- The Moisture Sensitivity Level rating according to the JEDEC industry standard classifications, and peak solder temperature.

Important Information and Disclaimer:The information provided on this page represents TI's knowledge and belief as of the date that it is provided. TI bases its knowledge and belief on information provided by third parties, and makes no representation or warranty as to the accuracy of such information. Efforts are underway to better integrate information from third parties. TI has taken and continues to take reasonable steps to provide representative and accurate information but may not have conducted destructive testing or chemical analysis on incoming materials and chemicals. TI and TI suppliers consider certain information to be proprietary, and thus CAS numbers and other limited information may not be available for release.

In no event shall TI's liability arising out of such information exceed the total purchase price of the TI part(s) at issue in this document sold by TI to Customer on an annual basis.

IMPORTANT NOTICE

Texas Instruments Incorporated and its subsidiaries (TI) reserve the right to make corrections, modifications, enhancements, improvements, and other changes to its products and services at any time and to discontinue any product or service without notice. Customers should obtain the latest relevant information before placing orders and should verify that such information is current and complete. All products are sold subject to TI's terms and conditions of sale supplied at the time of order acknowledgment.

TI warrants performance of its hardware products to the specifications applicable at the time of sale in accordance with TI's standard warranty. Testing and other quality control techniques are used to the extent TI deems necessary to support this warranty. Except where mandated by government requirements, testing of all parameters of each product is not necessarily performed.

TI assumes no liability for applications assistance or customer product design. Customers are responsible for their products and applications using TI components. To minimize the risks associated with customer products and applications, customers should provide adequate design and operating safeguards.

TI does not warrant or represent that any license, either express or implied, is granted under any TI patent right, copyright, mask work right, or other TI intellectual property right relating to any combination, machine, or process in which TI products or services are used. Information published by TI regarding third-party products or services does not constitute a license from TI to use such products or services or a warranty or endorsement thereof. Use of such information may require a license from a third party under the patents or other intellectual property of the third party, or a license from TI under the patents or other intellectual property of TI.

Reproduction of information in TI data books or data sheets is permissible only if reproduction is without alteration and is accompanied by all associated warranties, conditions, limitations, and notices. Reproduction of this information with alteration is an unfair and deceptive business practice. TI is not responsible or liable for such altered documentation.

Resale of TI products or services with statements different from or beyond the parameters stated by TI for that product or service voids all express and any implied warranties for the associated TI product or service and is an unfair and deceptive business practice. TI is not responsible or liable for any such statements.

Following are URLs where you can obtain information on other Texas Instruments products and application solutions:

Products		Applications	
Amplifiers	amplifier.ti.com	Audio	www.ti.com/audio
Data Converters	dataconverter.ti.com	Automotive	www.ti.com/automotive
DSP	dsp.ti.com	Broadband	www.ti.com/broadband
Interface	interface.ti.com	Digital Control	www.ti.com/digitalcontrol
Logic	logic.ti.com	Military	www.ti.com/military
Power Mgmt	power.ti.com	Optical Networking	www.ti.com/opticalnetwork
Microcontrollers	microcontroller.ti.com	Security	www.ti.com/security
		Telephony	www.ti.com/telephony
		Video & Imaging	www.ti.com/video
		Wireless	www.ti.com/wireless

Mailing Address: Texas Instruments
Post Office Box 655303 Dallas, Texas 75265